

Aquabox Installation Guide

Required Materials and Equipment List

- Acceptable fill materials per Table 1
- Nonwoven geotextile fabrics
- Aquabox modules, Cube modules, sidewall grids, top caps, half bases, and joints
- Rubber mallet for securing locking joints.
- ADS pipe and fittings

Note: Aquabox module pallets are 2.5' x 5' x 8.5' (0.8 x 1.5 x 2.6 m) and weigh approximately 1600 lbs. (730 kg) and the Cube pallets are 2.5' x 5' x 8.5' (0.8 x 1.5 x 2.6 m) and weigh approximately 600 lbs. (300 kg). Unloading modules requires 72" (1.8 m) (min.) forks and/or tie downs (straps, chains, etc).

Important Notes:

- A. This installation guide provides the minimum requirements for proper installation of Aquabox. Nonadherence to this guide may result in damage to modules during installation. Replacement of damaged modules during or after backfilling is costly and very time consuming. It is recommended that all installers are familiar with this guide, and that the contractor inspects the modules for distortion, damage and system integrity as work progresses.
- B. Care should be taken in the handling of Aquabox modules and other components. Avoid dropping, prying or excessive force on the modules during removal from pallet and initial placement.

Requirements for System Installation



Excavate bed and prepare subgrade per engineer's plans. Plans and specifications should include Best Management Practices (BMPs) to deter contamination of open pits during construction.



Place nonwoven geotextile over prepared soils and up excavation walls. Install underdrains and StormGrid geotextile if required.



Place clean, crushed, angular stone foundation 6" (150 mm) min. Compact to achieve a flat surface.



Place a second layer of nonwoven geotextile over the base stone layer and up the excavation walls. This layer of geotextile will wrap the Aquabox module and prevent stone from entering the system.

Assembly of Aquabox Modules and Accessories

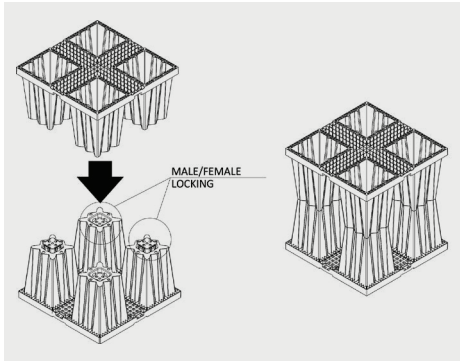

Each Aquabox module consists of two halves. Assemble the modules by laying one half on the ground, placing the other half on top, and applying some pressure to seat the connection. Assembly can be done inside or outside of the excavation.

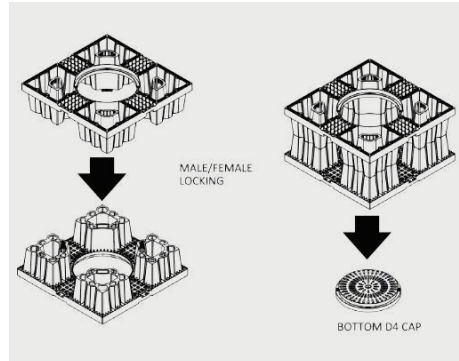

The Aquabox Cube module is assembled in the same manner as the full unit. Cube modules can be used to create half-height layers or for inspection shafts within the system. Cube modules on the bottom layer of the system must have the D4 cap installed on the bottom face.

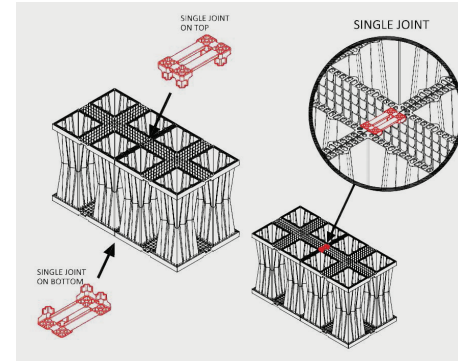

Modules are linked using joints. The single joints are used on the top and bottom surface of the assembly. Joints are inserted into the corresponding slots on each module. Do not place joints between the Isolator Row (if present) and any surrounding modules.

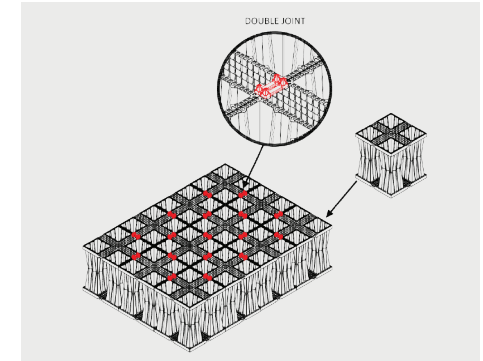

For multi-layer systems, the double joint is used to link modules in between layers. Note: the single joint is still used on the top and bottom faces in these configurations.

Assembly of the Aquabox System

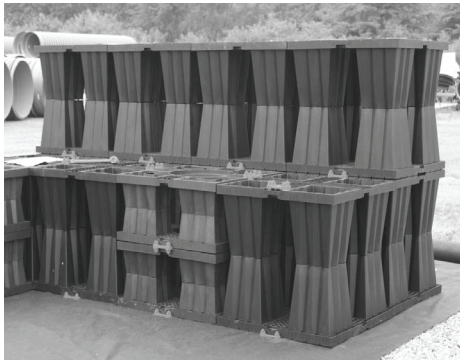

Begin placing modules at one corner of the system and work across. For ease of access, follow one row behind with installation the upper layers of modules. Place single/double joints and Cube module as required by the system configuration.



Place top caps and single joints on the upper surface of the system as installation progresses. The corner of the top caps must be cut to cover any Cube modules.

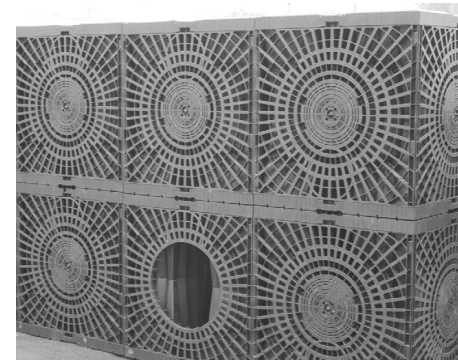

Follow with installation of the Aquabox full and half side panels around the exterior of the system. Where inlet/outlet connections are planned, cut the side panel to the appropriate size before installing it on the Aquabox system.



Wrap the completed assembly with the innermost layer of nonwoven geotextile. Cut locations in the geotextile for inspection ports and side connections.

Inspection & Maintenance

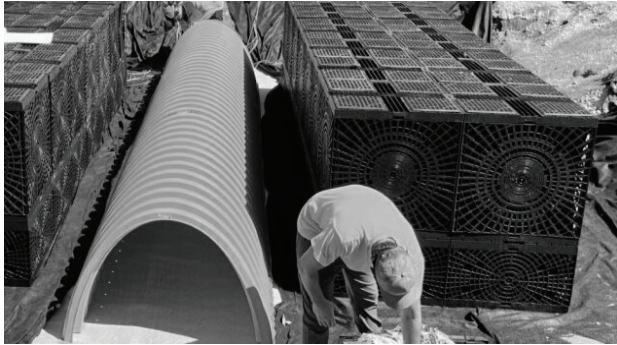

The StormTech Isolator Row Plus may be coupled with Aquabox modules as a premier water quality feature that captures sediment and provides easy access for inspection & maintenance. Please refer to *Installation Guidance: StormTech Isolator Row Plus with Aquabox* for specific installation guidance.

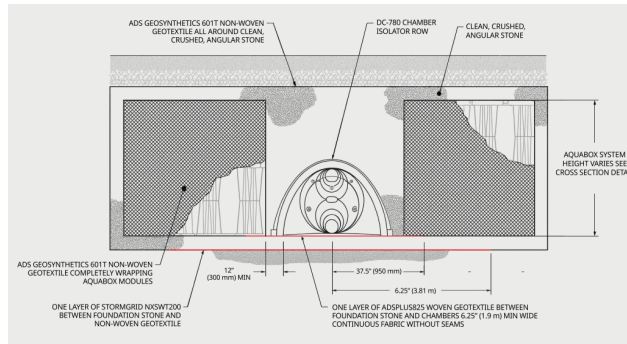

Aquabox systems 1.0-layer & taller utilize the DC-780 for the Isolator Row Plus. DC-780s require ADS StormGrid200 be installed at the base of stone, centered below the chamber. Please refer to *Installation Guidance: StormTech Isolator Row Plus with Aquabox* for additional installation instructions.



The Aquabox maintenance row is another water quality feature that can be used on Aquabox systems. The option provides an alternative to the StormTech Isolator Row Plus in a smaller footprint, offering sediment capture on sites with space constraints. Please refer to the *Aquabox O&M Manual* for specific instructions on installation of this feature.

Making Side Connections

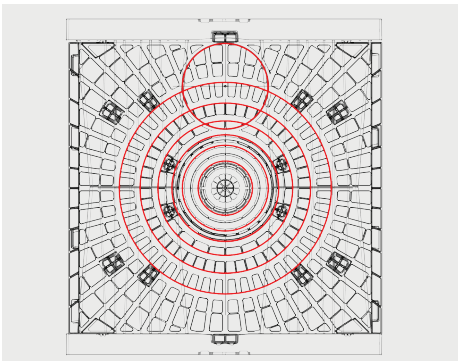

Side panels can be cut to allow connections of 4" (100 mm) up to 18" (450 mm) corrugated pipe. Side panels should be cut before being installed on the modules.

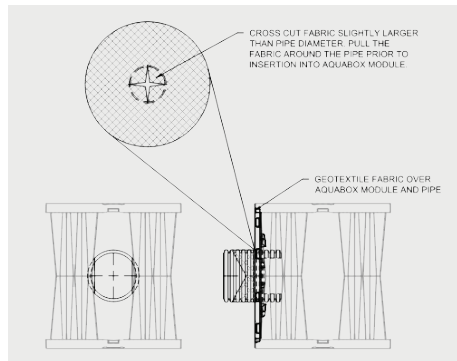

At the location of the pipe connection, cross-cut the geotextile to slightly larger than the pipe diameter. Connecting pipes should be inserted at least 6" (150 mm) into the side panel.

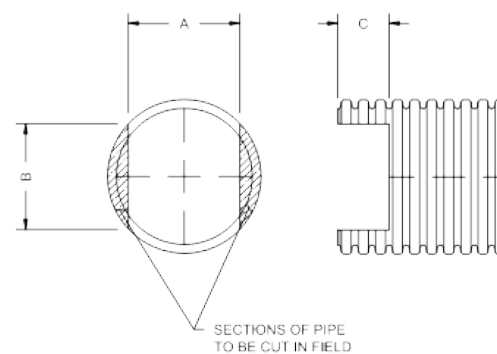

Pipe connection of 10" (250 mm) and larger require field cuts to allow full insertion. Cut the end of the pipe as detailed above.

Pipe Diameter	Side Panel Width	Side Panel Height	Number of Corrugations
10" (250 mm)	8.25" (203 mm)	7.75" (197 mm)	4 Corrugations
12" (300 mm)	7.75" (197 mm)	12.00" (300 mm)	3 Corrugations
15" (375 mm)	7.50" (190 mm)	16.00" (406 mm)	3 Corrugations
18" (450 mm)	7.25" (184 mm)	20.00" (508 mm)	2 Corrugations

Backfill of Modules – Embedment Stone

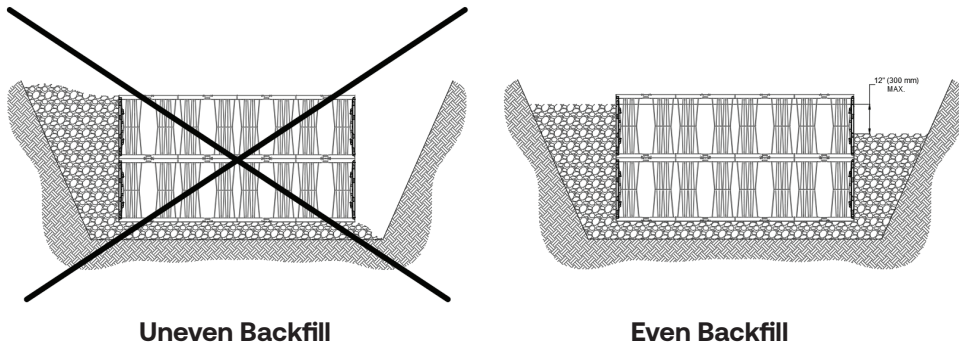

Backfill around the the system evenly. Backfill heights should not differ by more than 12" (300 mm) around the perimeter. The space between the system and the edge of the excavation should be filled entirely with each lift.



Backfill evenly around the perimeter until embedment stone reaches the top of the modules and a minimum 6" (150 mm) of cover stone is in place. The recommended backfill method is with an excavator from outside the bed.

Final Backfill of Modules – Fill Material



1) Only after modules have been backfilled with a minimum 6" (150 mm) of cover stone on top of modules can skid loaders and small LGP dozers be used to final grade cover stone and backfill material in accordance with ground pressure limits in Table 2.



2) Install nonwoven geotextile over stone. Geotextile must overlap 24" (600 mm) where edges meet.

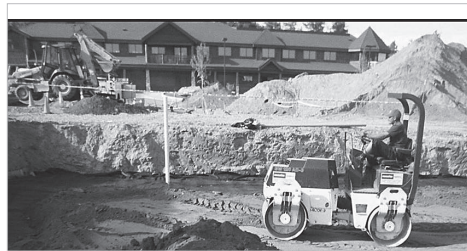

3) Compact at 18" (450 mm) of fill.

Figure 1- Inspection Port Detail

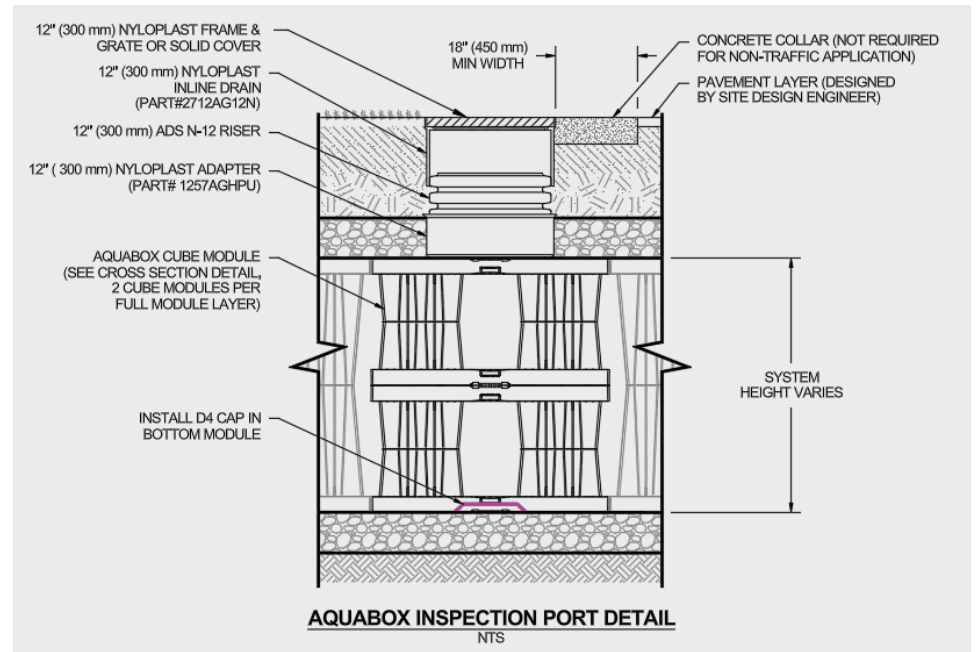

Table 1- Acceptable Fill Materials

Material Location	Description	AASHTO M43 Designation ¹	Compaction/Density Requirement
D Final Fill: Fill material for layer 'D' starts from the top of the 'C' layer to the bottom of flexible pavement or unpaved finished grade above. Note that the pavement subbase may be part of the 'D' layer.	Any soil/rock materials, native soils or per engineer's plans. Check plans for pavement subgrade requirements.	N/A	Prepare per site design engineer's plans. Paved installations may have stringent material and preparation requirements.
C Initial Fill: Fill Material for layer 'C' starts from the top of the embedment stone ('B' layer) to 18" (450 mm) above the top of the module. Note that pavement subbase may be part of the 'C' layer.	Granular well-graded soil/ aggregate mixtures, <35% fines or processed aggregate. Most pavement subbase materials can be used in lieu of this layer.	AASHTO M1451 A-1, A-2-4, A-3 or AASHTO M431 3, 357, 4, 467, 5, 56, 57, 6, 67, 68, 7, 78, 8, 89, 9, 10	Begin compaction after 12" (300 mm) of material over the Aquabox modules is reached. Compact additional layers in 6" (150 mm) max. lifts to a min. 95% Proctor density for well graded material and 95% relative density for processed aggregate materials. Roller gross vehicle weight not to exceed 12,000 lbs (53 kN). Dynamic force not to exceed 20,000 lbs (89 kN).
B Perimeter Stone: Fill surrounding the Aquabox modules from the foundation stone ('A' layer) to the 'C' layer above.	Clean, crushed, angular stone	AASHTO M43 ¹ 467, 5, 56, 57	No compaction required.
A Foundation Stone: Fill below Aquabox modules from the subgrade up to the bottom of the Aquabox module.	Clean, crushed, angular stone	AASHTO M43 ¹ 467, 5, 56, 57	Plate compact or roll to achieve a flat surface. ^{2,3}

Please Note:

- The listed AASHTO designations are for gradations only. The stone must also be clean, crushed, angular. For example, a specification for #57 stone would state: "clean, crushed, angular no. 57 (AASHTO M43) stone".
- ADS Aquabox compaction requirements are met for 'A' location materials when placed and compacted in 6" (150 mm) (max) lifts using two full coverages with a vibratory compactor.
- Where infiltration surfaces may be comprised by compaction, for standard design load conditions, a flat surface may be achieved by raking or dragging without compaction equipment. For special load designs, contact ADS for compaction requirements.
- Once layer 'C' is placed, any soil/material can be placed in layer 'D' up to the finished grade. Most pavement subbase soils can be used to replace the material requirements of layer 'C' or 'D' at the site design engineer's discretion.

Figure 2 - Fill Material Locations

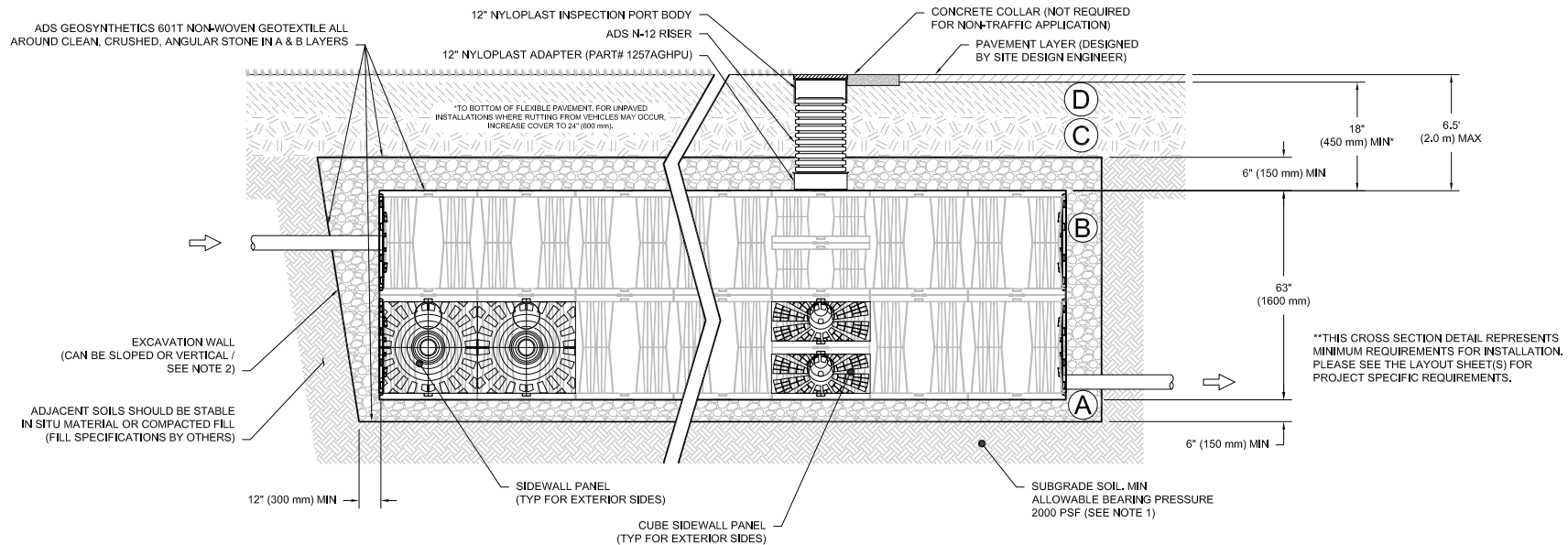

Notes:

1. 36" (900 mm) of stabilized cover materials over the modules is recommended during the construction phase if general construction activities, such as full dump truck travel and dumping, are to occur over the bed.
2. During paving operations, dump truck axle loads on 24" (600mm) of cover may be necessary. Precautions should be taken to avoid rutting of the road base layer, to ensure that compaction requirements have been met, and that a minimum of 24" (600mm) of cover exists over the modules. Contact ADS for additional guidance on allowable axle loads during paving.
3. Ground pressure for track dozers is the vehicle operating weight divided by total ground contact area for both tracks. Excavators will exert higher ground pressures based on loaded bucket weight and boom extension.
4. Mini-excavators (<8,000lbs/3,628 kg) can be used with at least 6" (150 mm) of stone over the modules and are limited by the maximum ground pressures in Table 2 based on a full bucket at maximum boom extension.
5. ADS does not require compaction of initial fill at 12" (300 mm) of cover. However, requirements by others for 6" (150 mm) lifts may necessitate the use of small compactors at 12" (300 mm) of cover
6. Storage of materials such as construction materials, equipment, spoils, etc. should not be located over the Aquabox system. The use of equipment over the Aquabox system not covered in Table 2 (ex. soil mixing equipment, cranes, etc) is limited. Please contact ADS for more information.
7. Allowable track loads based on vehicle travel only. Excavators shall not operate on module beds until the total backfill reaches 3 feet (900 mm) over the entire bed.

Table 2 - Maximum Allowable Construction Vehicle Loads⁶

Material Location	Fill Depth over Modules in. (mm)	Max Allowable Wheel Loads		Max Allowable Track Loads ⁶		Max Allowable Roller Loads
		Max Axle Load for Trucks lbs (kN)	Max Wheel Load for Loaders lbs (kN)	Track Width in. (mm)	Max Ground Pressure psf (kPa)	Max Drum Weight or Dynamic Force lbs (kN)
Ⓓ Final Fill Material	36" (900) Compacted	32,000 (142)	16,000 (71)	12" (305)	3880 (186)	38,000 (169)
				18" (457)	2640 (126)	
				24" (610)	2040 (97)	
				30" (762)	1690 (81)	
				36" (914)	1470 (70)	
Ⓒ Initial Fill Material	24" (600) Compacted	32,000 (142)	16,000 (71)	12" (305)	2690 (128)	20,000 (89)
				18" (457)	1880 (90)	
				24" (610)	1490 (71)	
				30" (762)	1280 (61)	
				36" (914)	1150 (55)	
	24" (600) Loose/Dumped	32,000 (142)	16,000 (71)	12" (305)	2390 (114)	20,000 (89) Roller gross vehicle weight not to exceed 12,000 lbs. (53 kN)
				18" (457)	1700 (81)	
				24" (610)	1370 (65)	
				30" (762)	1190 (57)	
	18" (450)	32,000 (142)	16,000 (71)	12" (305)	2110 (101)	20,000 (89) Roller gross vehicle weight not to exceed 12,000 lbs. (53 kN)
				18" (457)	1510 (72)	
				24" (610)	1250 (59)	
30" (762)				1100 (52)		
12" (300)	16,000 (71)	NOT ALLOWED	12" (305)	1540 (74)	20,000 (89) Roller gross vehicle weight not to exceed 12,000 lbs. (53 kN)	
			18" (457)	1190 (57)		
			24" (610)	1010 (48)		
			30" (762)	910 (43)		
			36" (914)	840 (40)		
Ⓑ Perimeter Stone	6" (150)	8,000 (35)	NOT ALLOWED	12" (305)	1070 (51)	NOT ALLOWED
				18" (457)	900 (43)	
				24" (610)	800 (38)	
				30" (762)	760 (36)	
				36" (914)	720 (34)	

Table 3 - Placement Methods and Descriptions

Material Location	Placement Methods/ Restrictions	Wheel Load Restrictions	Track Load Restrictions	Roller Load Restrictions
		See Table 2 for Maximum Construction Loads		
Ⓓ Final Fill Material	A variety of placement methods may be used. All construction loads must not exceed the maximum limits in Table 2.	36" (900 mm) minimum cover required for dump trucks to dump over modules.	Reference Table 2 for allowable track pressures up to 36" (900 mm) cover ⁴	Reference Table 2 for allowable roller loads up to 36" (900 mm) cover.
Ⓒ Initial Fill Material	Excavator positioned off bed recommended. Small excavator allowed over modules. Small dozer allowed.	Asphalt can be dumped into paver when compacted pavement subbase reaches 24" (600 mm) above top of modules.	Small LGP track dozers & skid loaders allowed to grade cover stone with at least 12" (300 mm) stone under tracks at all times.	Use dynamic force of roller only after compacted fill depth reaches 18" (450 mm) over modules.
Ⓑ Perimeter Stone	No equipment allowed on bare modules. Use excavator or stone conveyor positioned off bed or on foundation stone to evenly fill around all modules to at least 6" (150 mm) above top of the modules.	No wheel loads allowed. Material must be placed outside the limits of the module bed.	Only low-pressure tracked equipment allowed.	No rollers allowed.
Ⓐ Foundation Stone	No Aquabox restrictions. Contractor responsible for any conditions or requirements by others relative to subgrade bearing capacity, dewatering or protection of subgrade.			

For technical and product information visit adspipe.com

