

# Aquabox

Aquabox is a globally proven modular underground system designed for sustainable stormwater management. Systems have been installed in 25 countries.

The Aquabox system is designed primarily to be used under parking lots, thus maximizing land usage for private (commercial) and public applications. The Aquabox can also be used in conjunction with Green Infrastructure, thus enhancing the performance and extending the service life of these practices.

## Why Aquabox

- Structurally superior compared to the majority of crates on the market today
- Fast and easy to install, allows for a high load resistance, and has a 96% void
- Manufactured from recycled polypropylene with fiberglass additive
- Adaptable components enable highly customized layouts, creating the perfect fit for complex sites
- Meets or exceeds the requirements of ASTM F3754

## Features

- Fast and easy installation
- High load resistance
- Open and flexible system that can be used for both detention, retention (infiltration) and water harvesting applications
- 96% void
- 29.5" x 29.5" x 31.5" (750 x 750 x 800 mm) modular modules that are easy to manage
- 15.24ft<sup>3</sup> (0.43 m<sup>3</sup>) per Aquabox module



## Benefits

- Internal configuration makes the system easily accessible for inspection, maintenance & cleaning.
- Modules are stackable, allowing 16,000 ft<sup>3</sup> (453.1 m<sup>3</sup>) of installed volume to be transported in a single truckload
- Designed for the passage of heavy vehicles, load class HS20 Internal configuration makes the system easily accessible for inspection, maintenance & cleaning.

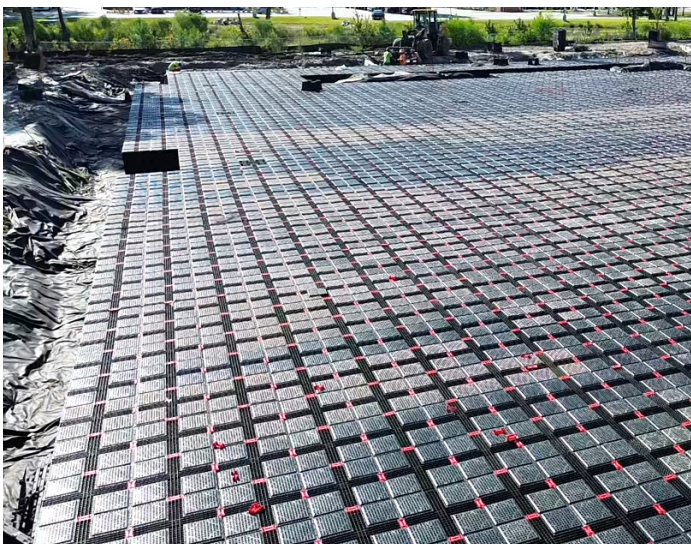

# Aquabox Specifications

<b>Dimensions</b>	29.5" x 29.5" x 31.5" (750 x 750 x 800 mm)
<b>Weight</b>	45 lbs (20.4 kg)
<b>Material</b>	Recycled polypropylene with glass additive
<b>Net volume</b>	15.24 ft <sup>3</sup> (0.43 m <sup>3</sup> )
<b>Void</b>	96%
<b>Pallet Size</b>	385.8" x 60.0" x 101.6" (9800 x 1520 x 2580 mm)
<b>Number of pieces per pallet</b>	80

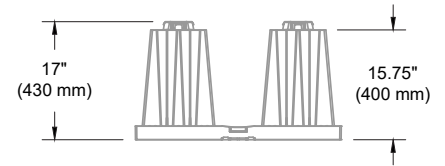
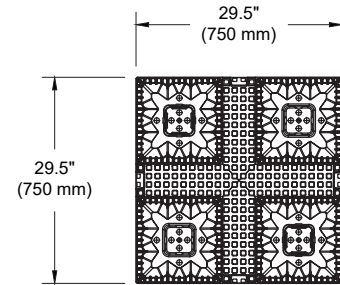
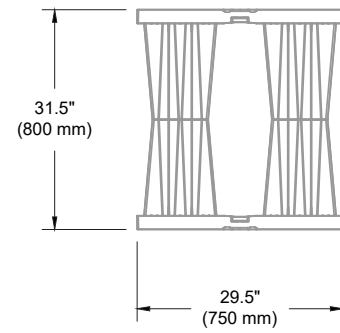

## Cross Section

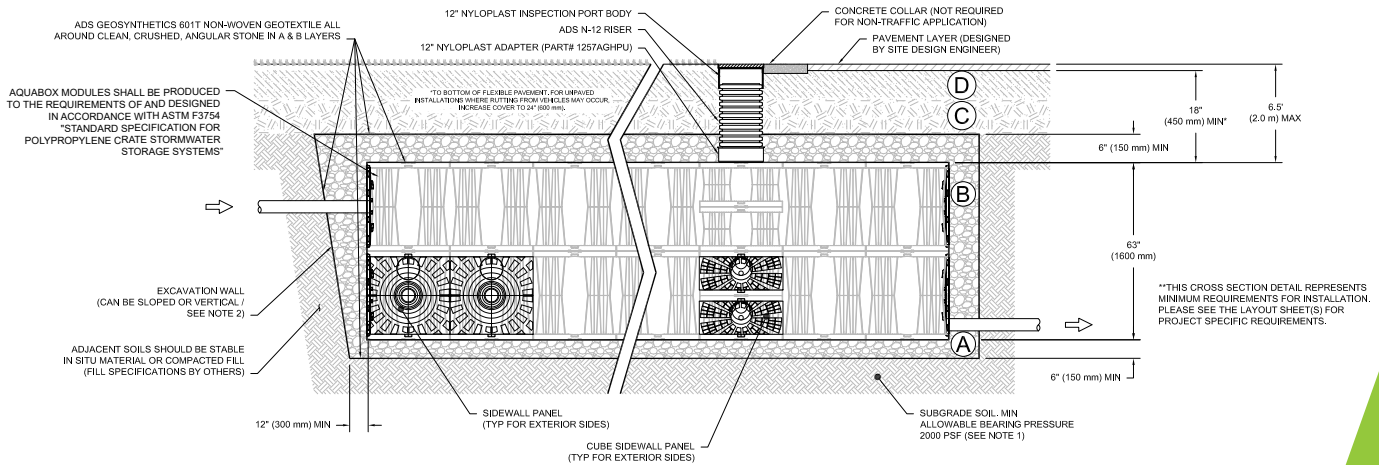

Visit [adspipe.com/water-management-solutions/detention-infiltration/aquabox](https://adspipe.com/water-management-solutions/detention-infiltration/aquabox) for more information



adspipe.com