

# Technical Note

## TN 1.08 Water Quality Device Oil Storage Volumes

### Introduction

The information in this document is designed to provide values to general storage capacities (gallons) for oil and grease or free phase oil/petroleum product spills into ADS water quality devices. The information provided is not intended to be used for project design (i.e., maximum flow rates, etc.). Spill incidents that involve high velocities into these devices will yield different results/capacities. It is assumed that the spill flow rates will be less than 10% of the maximum treatment rate (MTR) into an individual ADS Water Quality device.

Oil and Grease (O&G) is a common term for measuring total petroleum hydrocarbons (TPH), lubricating oils, oil and oil byproducts found in stormwater runoff. It is assumed that the densities for these types of O&G pollutants are less than that of water (i.e., less than 1g/cm<sup>3</sup>).

### Spill Capacities

For applications located at sensitive maintenance, transportation, fueling operations, spill containment is a concern. Most of these sites have safety measures and alarms to alert the owner that a spill has occurred. ADS's Arcadia™, BaySeparator, Barracuda®, and Water Quality Unit (WQU), all have the capability to store spills that occur in non-storm events. Table 1 lists the spill containment volumes for each of our units.

Diagrams provided (Figures 1, 2, 3, and 4) show how and where the spilled material is stored within a given ADS unit. It is the responsibility of the owner to remediate and extract the free phase oil shortly after the spill event has occurred and prior to subsequent storm event.

**Table 1: Spill Capacities**

Arcadia Unit	Spill Capacity, gallons (L)
AR3	24 (90)
AR4	53 (200)
AR5	96 (363)
AR6	161 (609)
AR8	359 (1358)
AR10	686 (2596)

BaySeparator Unit	Spill Capacity, gallons (L) <sup>1</sup>
1/2K	226 (855)
1K	320 (1211)
3K	456 (1726)
5K	621 (2350)
10K	1567 (5931)

<sup>1</sup> BaySeparator with larger secondary manholes can store more gallons of oil. Contact ADS Engineering for information on larger storage systems for the BaySeparator

Barracuda Unit	Spill Capacity, gallons (L)
S3	26 (98)
S4	51 (193)
S6	115 (435)
S8	212 (802)

Water Quality Unit	Spill Capacity, gallons (L)
3612	221 (836)
3620	225 (851)
3640	470 (1779)
4220	285 (1078)
4240	605 (2290)
4820	410 (1552)
4840	860 (3255)
6020	650 (2460)
6040	1380 (5223)

## Spill Capacity Details

For each ADS product, the spill oil will be stored in an accessible area of the device. For Arcadia it will be contained in the top baffle area below the invert out of the system (See Figure 1). For the Barracuda it will be contained in the inletting "bowl" area below the invert out of the system (See Figure 2). For the BaySeparator, the spill will be stored in the secondary manhole and stored between the invert into the secondary manhole and the top elevation invert out to the BaySeparator™ unit (See Figure 3). For the ADS Water Quality Unit the area will be storage between the elevations of sedimentation internal weir and the effluent exit "plate" opening to the final section of the WQU (See Figure 4).

**Figure 1: Arcadia Oil Capacity Zone**

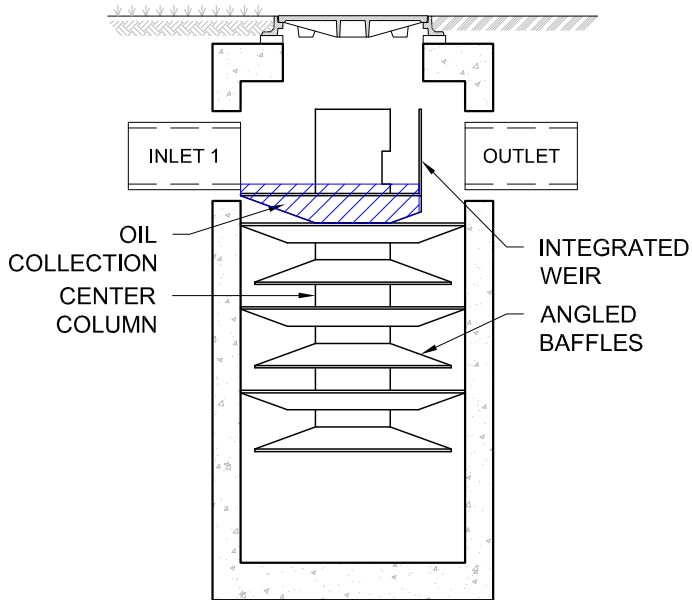

**Figure 2: Barracuda Oil Capacity Zone**

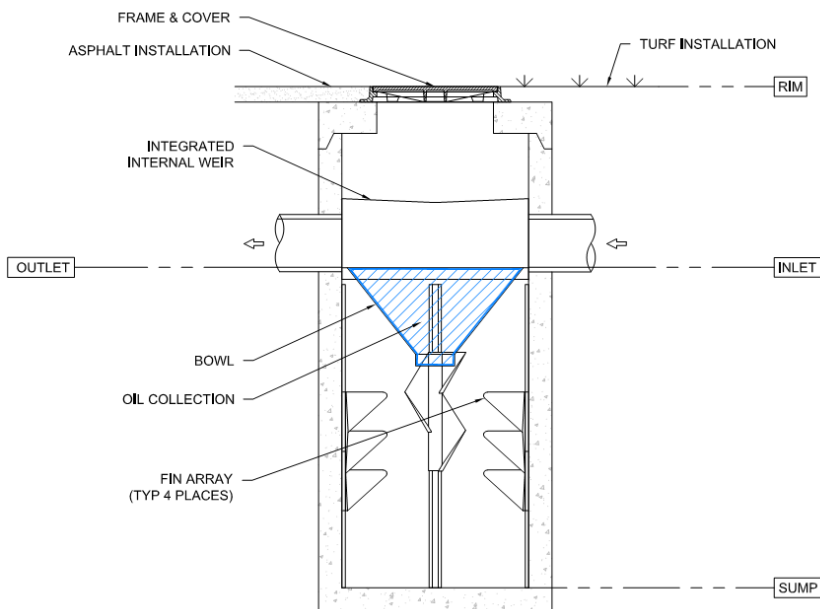

**Figure 3: BaySeparator Oil Capacity Zone**

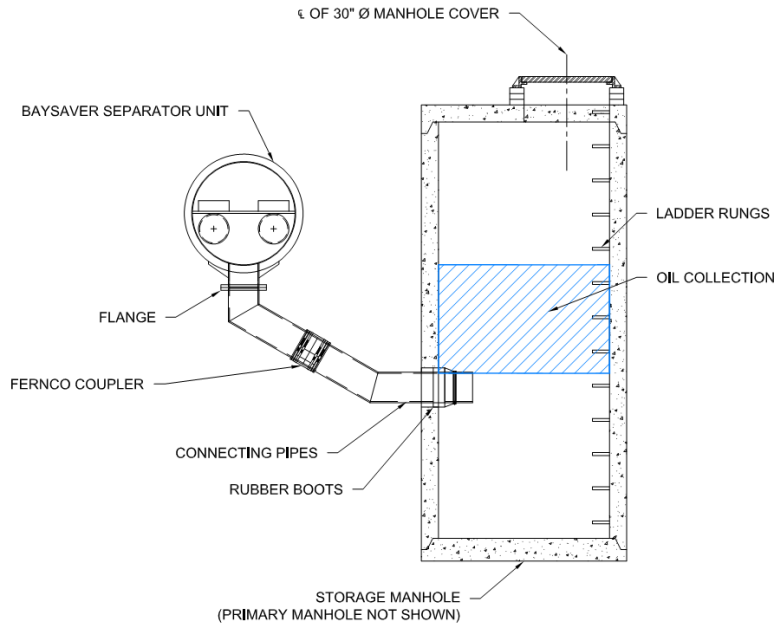

**Figure 4: Water Quality Unit Oil Capacity Zone**

