

Aquabox Design Manual

Modular System For Stormwater Management

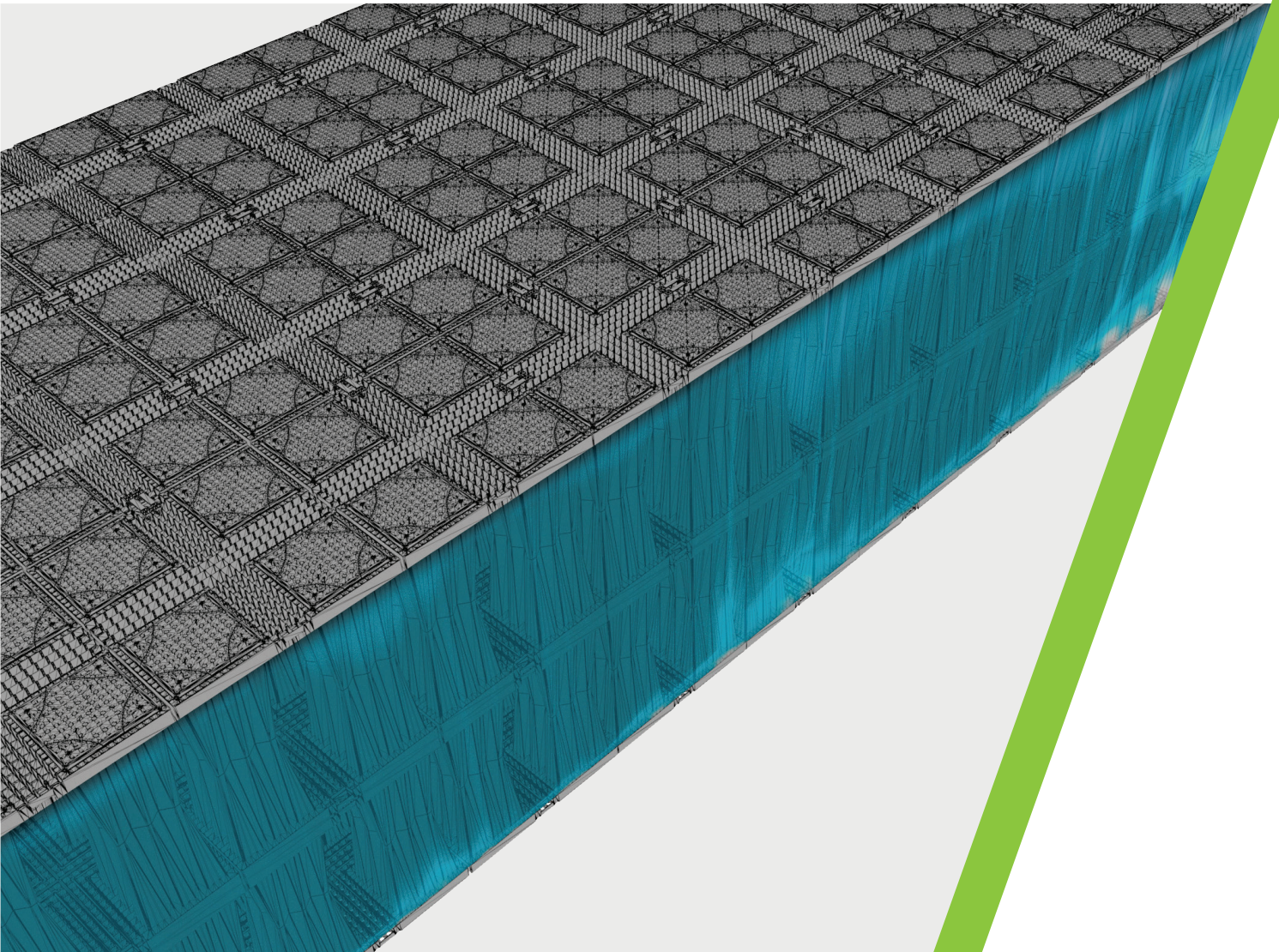

Table of Contents

1.0 Aquabox System	2
2.0 Hydraulic Design	8
3.0 Structural Design	10
4.0 Aquabox System Installation.....	12
5.0 Inspection & Maintenance	19
6.0 Transport and Logistics.....	20



1.0 Aquabox System

1.1 Purposes and Functions

Heavy rainfalls combined with the expansion of urban impervious surfaces are showing the need for efficient and sustainable stormwater management solutions.

The Aquabox storage system offers several solutions, suitable for varying stormwater management requirements using both detention and retention techniques. Stormwater detention with a controlled release to the watershed and/or receiving waters helps to mitigate the potential negative impacts by helping to reduce flooding and degraded water quality during heavy rainfall events. In short, the Aquabox system offers a wide range of solutions capable to addressing the specific needs of a development project.

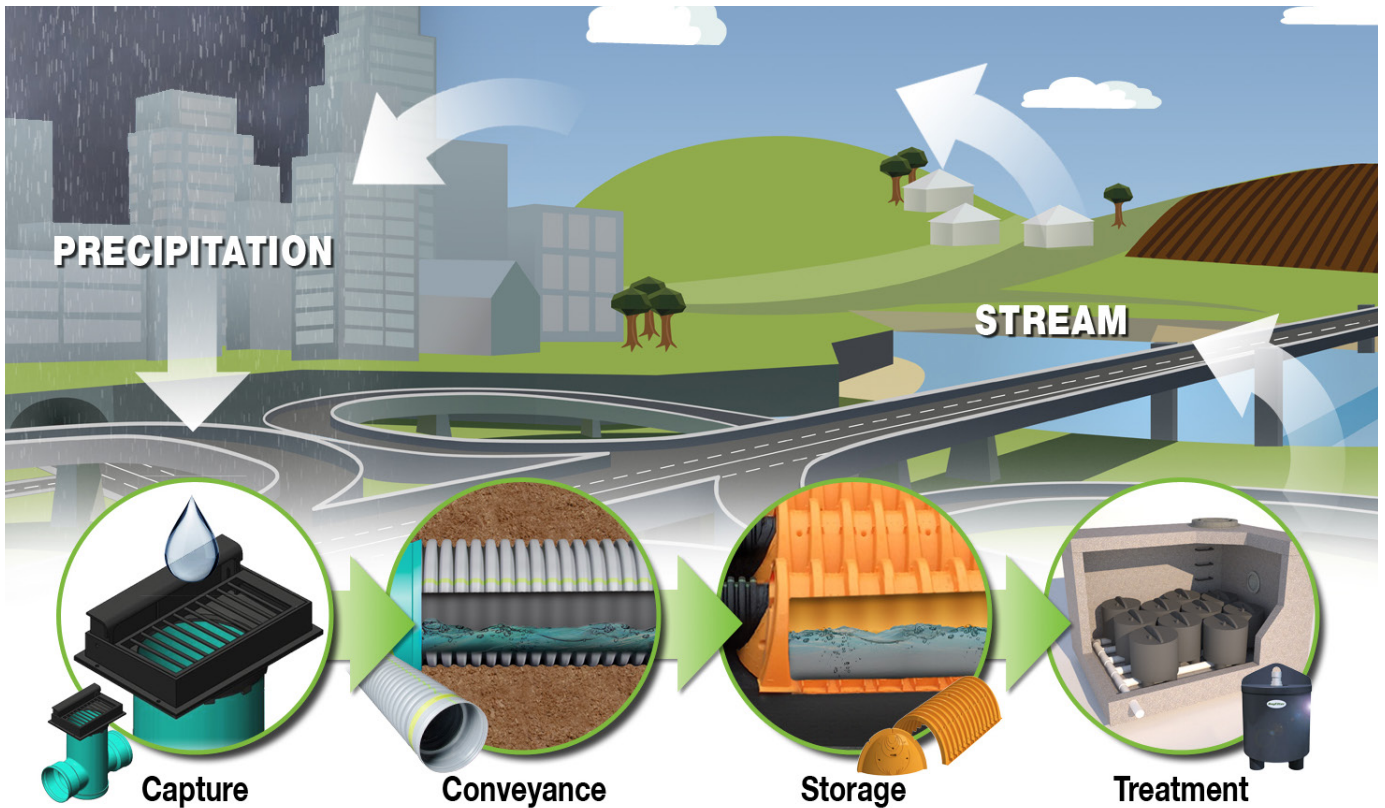
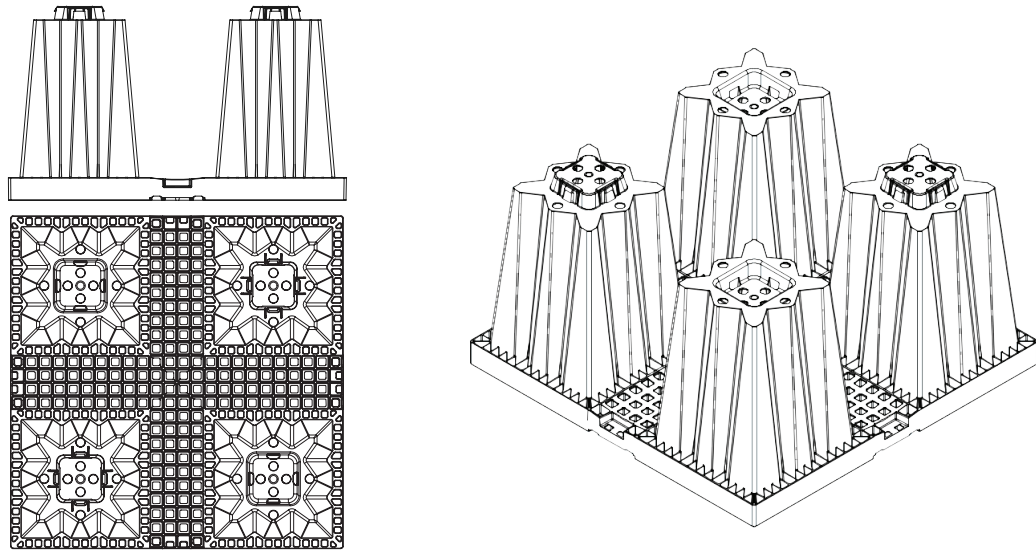

1.2 Brief Description

Aquabox is a modular system with a truncated pyramid structure made of recycled polypropylene with glass additive. It is designed to create an underground storage system for stormwater management.

Aquabox is used for the control of rainwater and to reduce possible flooding created by the increase of urban areas. It creates infiltration, detention or harvesting, which enhances water by reusing it.

The modules are assembled on site and installed. The modules are interlocked by means of special connectors that guarantee the stability of the tank. Aquabox has high mechanical resistance, so it can be installed both in urban areas and in industrial / commercial areas where there is an intense transit of heavy vehicles.

Below is the technical data for the single piece (1 Aquabox = 2 pieces).

Aquabox allows one to store up to 0.4 m³ (15.24 ft³) of rainwater per module, thanks to its very high porosity of 96%. The Aquabox maintenance row traps suspended sediments near the inlet for easy inspection and maintenance.

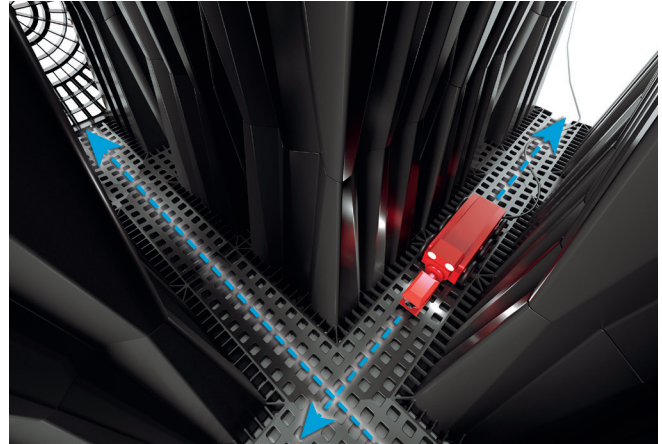

Module dimensions of Aquabox

Aquabox is designed for the passage of heavy vehicles, load class HS20. The basin is equipped with access points for inspection and cleaning of the basin.

Dimensions	750 x 750 x 800 mm (29.5" x 29.5" x 31.5")
Weight	20.4 kg (45 lbs)
Material	Recycled polypropylene with glass additive
Net volume	0.43 m ³ (15.24 ft ³)
Porosity	96%
Pallet Size	800 x 1520 x 2580 mm (31.5" x 60.0" x 101.6")
Number of pieces per pallet	80

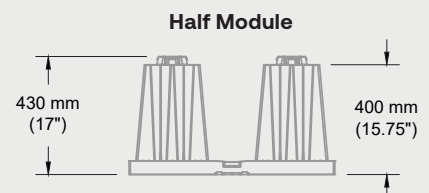
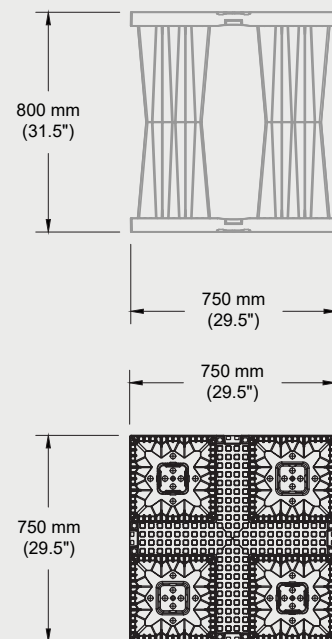

1.3 Overview

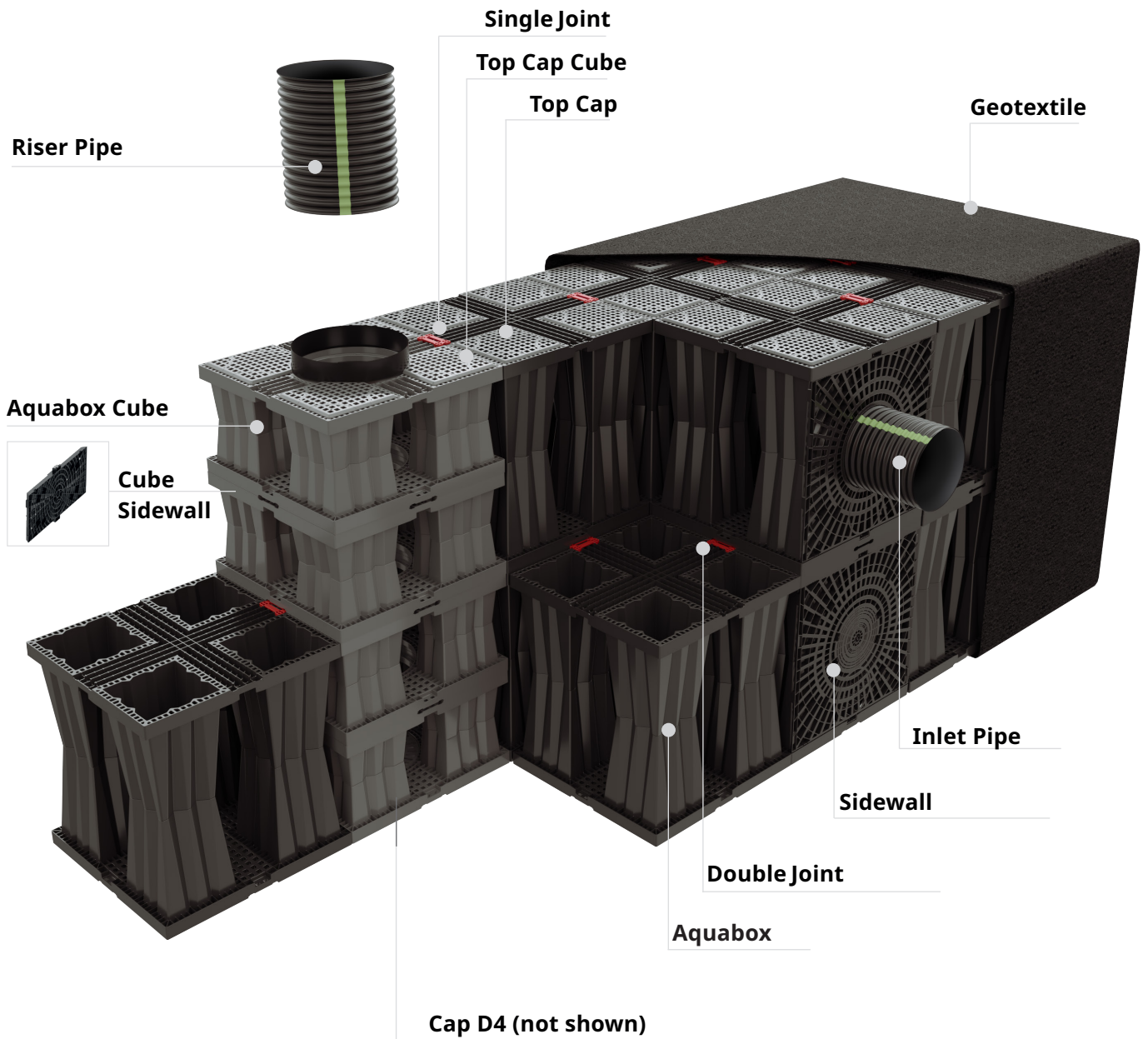

1.4 Accessory List and Technical Data

Below is the list of Aquabox accessories and related technical data:

1.4a Sidewall Grid

The Aquabox sidewall grid is used to close the sidewall surface of the storage and is affixed to Aquabox with a simple integrated clip.

Dimensions

750 x 750 x 32.5 mm (29.5" x 29.5" x 1.3")

Material

Recycled polypropylene with glass additive

Connection

100 mm (4"), 150 mm (6"), 200 mm (8"), 250 mm (10"),
300 mm (12"), 375 mm (15"), 450 mm (18")

Package size

450 x 1500 x 2500 mm (18" x 60" x 99")

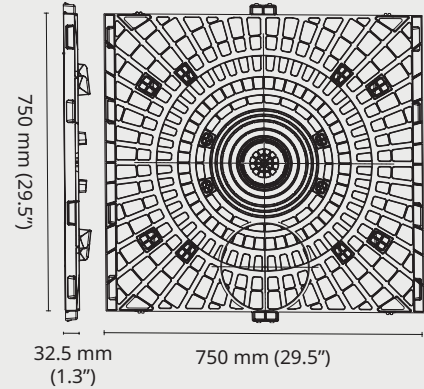

1.4b Top Cap

The upper surface of each module is equipped with four perforated closing caps that allow the passage of water. At the same time, these caps create a uniform walkable surface which is useful both during the installation phase and for the distribution of the loads acting on the system.

Dimensions

280 x 280 x 25 mm (11.2" x 11.2" x 1")

Material

Recycled polypropylene with glass additive

Package size

900 x 1200 x 2550 mm (36" x 48" x 101")

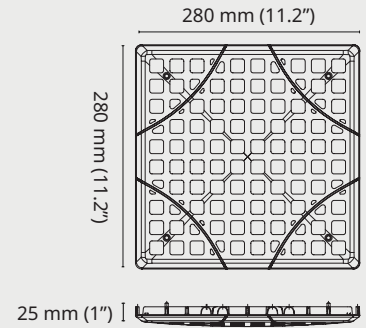

1.4c Single/Double Joints

Single: allows the horizontal connection of the top and bottom modules of the tank.

Double: allows the horizontal connection of the modules in the middle layers.

Single Joint

Dimensions

117.5 x 70 x 35 mm
(4.7" x 2.8" x 1.4")

Material

Recycled polypropylene
with glass additive

Color

Red

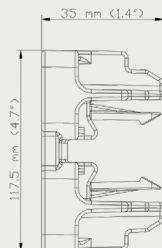

Double Joint

Dimensions

117.5 x 70 x 70 mm
(4.7" x 2.8" x 2.8")

Material

Recycled polypropylene
with glass additive

Color

Red

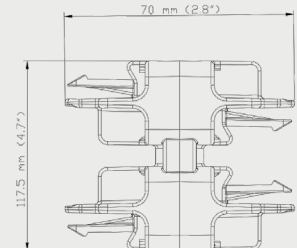

1.4d Aquabox Cube

Aquabox Cube is a modular system designed to make inspection points for the inspection and management of Aquabox underground storage system.

Dimensions

750 x 750 x 225 mm (29.5" x 29.5" x 9")

Material

Recycled polypropylene with glass additive

Net storage volume

0.11 m³ (3.74 ft³) / pcs

Porosity

94%

Package size

800 x 1520 x 2550 mm (32" x 60" x 101")

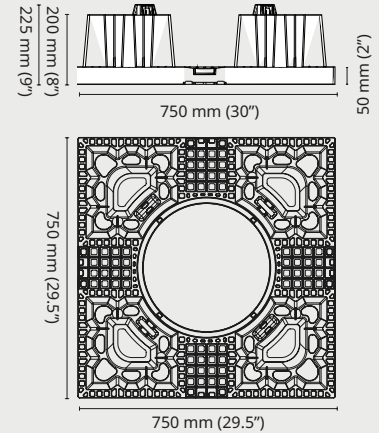

1.4e Sidewall Grid Cube

The Aquabox Cube side grid allows the sidewall closure of each single module if the inspection points are installed along the perimeter part and / or at a corner of the tank. If the Aquabox Cube is located inside the tank it does not require any side grid.

Dimensions

750 x 300 x 25 mm (29.5" x 12" x 1")

Material

Recycled polypropylene with glass additive

Connection

150 mm (6")

Package size

820 x 1220 x 2580 mm (33" x 48" x 102")

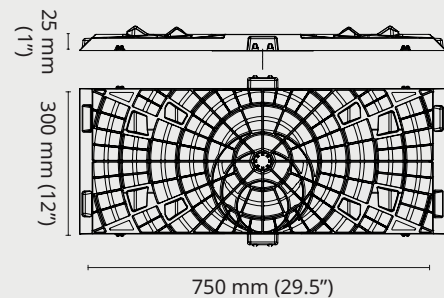

1.4f D4 Cap

The CAP D4 is used to close the Aquabox Cube at the bottom of the tank.

Dimensions

400 mm (16")

Material

Recycled polypropylene with glass additive

Package size

820 x 1220 x 2580 mm (33" x 48" x 102")

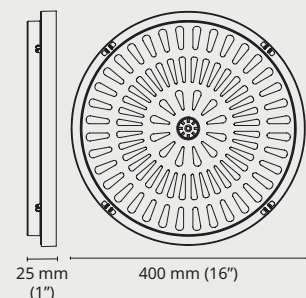

1.4g Aquabox Half Base

The Aquabox Half Base allows for a lower-profile configuration using one half of a full module. Two Half Bases combined with one full module piece form a Half Module, which can be installed in a 0.5-layer configuration. The Half Module can also be used to make half-height layers for 1.5- and 2.5-layer Aquabox systems.

Dimensions

750 x 375 x 50 mm (29.5" x 14.75" x 2")

Material

Recycled polypropylene with glass additive

Package size

800 x 1200 x 2580 mm (32" x 48" x 102")

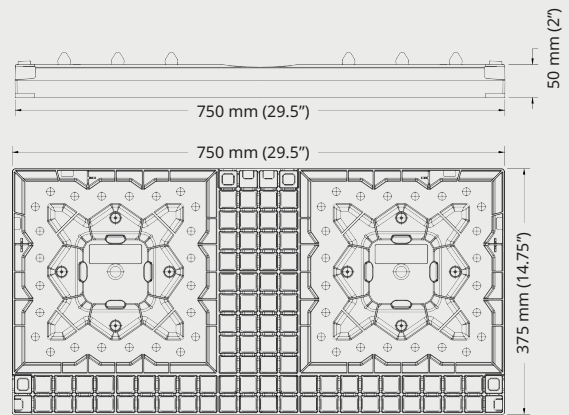

1.4h Aquabox Half Sidewall Grid

The Aquabox Half Sidewall Grid is used to close off any Half Modules installed along the perimeter of the system. Half Modules located entirely within the system, with no exposed sides, do not require a grid.

Please note that the Aquabox Half Sidewall Grid and the Aquabox Cube Sidewall Grid are not interchangeable.

Dimensions

750 x 350 x 40 mm (29.5" x 13.75" x 1.5")

Material

Recycled polypropylene with glass additive

Connection

100 - 250 mm (4"-10")

Package size

850 x 1200 x 2580 mm (34" x 48" x 102")

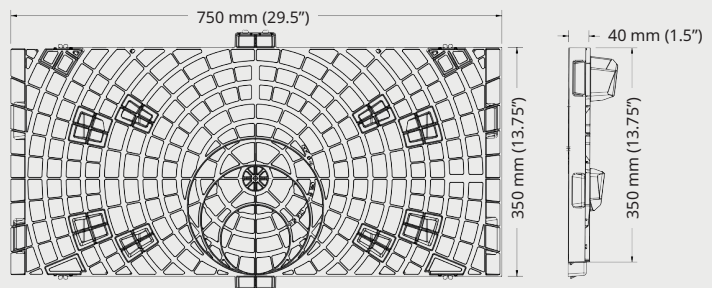

1.4i Aquabox Cube Top Cap

Like with the full module, the upper surface of each Cube Module require top caps be installed. These perforated caps allow for passage of water while also creating a uniform walking surface for both walking on during installation, and load distribution after installation.

The Cube top caps differ from standard top caps in that they have a corner removed to accommodate the open center of the Cube Module.

Dimensions

284 x 284 x 15 mm (11.2" x 11.2" x 0.6")

Material

Recycled polypropylene with glass additive

Package size

900 x 1200 x 2550 mm (36" x 48" x 101")

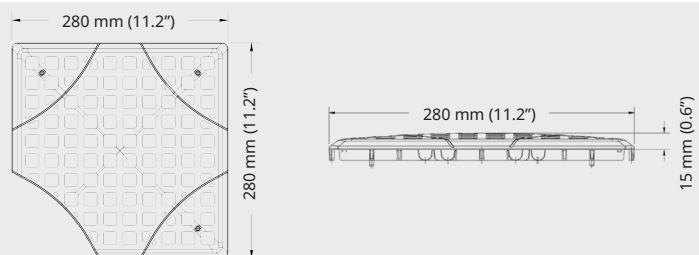

2.0 Hydraulic Design

2.1 General

The Aquabox system offers on site flexibility so the modules fit in any shape system. The open cellular design of the modules allows incoming stormwater runoff to freely distribute between the modules. The Aquabox can accept up to 450 mm (18") pipe. For larger inlet/outlet pipes please contact ADS Engineering Services for assistance.

One of the key advantages of the Aquabox system is its design flexibility. Modules may be configured into beds or trenches of various sizes or shapes. The modules can be centralized into a single large bed or designed into several smaller beds spread out across the site. The modular nature of Aquabox enhances the ability to develop both redevelopment sites and for new developments. The systems can be designed easily and efficiently around utilities, natural or man-made structures and any other limiting boundaries.

2.2 Required Volume

Determination of the required storage volume is done by the design engineer following local regulatory requirements. It is the responsibility of the design engineer to determine the design flow rates and storage volumes for the stormwater system and to ensure that the final design meets all conveyance and storage requirements. However, ADS will work with the design engineer to assist with Aquabox layouts that meet the design objectives.

2.3 Modeling The Module

Aquabox modules are placed in embedment stone with an assumed 40% porosity that can be included in the systems total storage volume. The storage table can be utilized for modeling the Aquabox module system in most modeling software programs. Contact ADS Engineering Services for an excel version of the table.

In most software programs there are options for stage elevation or area elevations inputs for creating the volume of the subsurface storage system. The data from the Aquabox cumulative storage spreadsheet can be copied into the software to accurately model the stage storage available in the Aquabox systems.

2.4 Module Section

Primary consideration in selecting the number of modules to stack are the restrictive depth layer, available subsurface storage area, vertical storage limits, cover heights and outfall restrictions. The flexibility of the Aquabox modules allow for very shallow systems and large volumes of stored water in a small area.

The table below shows the minimum and maximum finished grades to outlet invert for the various layers of the Aquabox modules. The storage volume per square foot has been provided to check how much volume can fit into an available area.

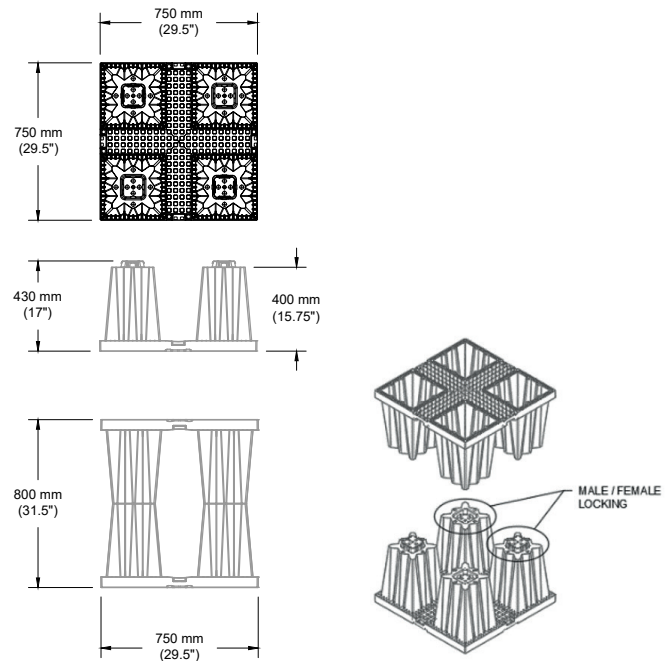

AQUABOX Layers	0.5	1	1.5	2	2.5	3
Min Cover, m (ft)	0.45 (1.5)	0.45 (1.5)	0.45 (1.5)	0.45 (1.5)	0.45 (1.5)	0.45 (1.5)
Max Cover, m (ft)	2.0 (6.5)	2.0 (6.5)	2.0 (6.5)	2.0 (6.5)	2.0 (6.5)	2.0 (6.5)
Module Height, mm (in)	450 (18)	800 (31.5)	1250 (49.5)	1600 (63)	2050 (81)	2400 (94.5)
Min depth ¹ , m (ft)	1.07 (3.50)	1.41 (4.63)	1.87 (6.13)	2.21 (7.25)	2.67 (8.75)	3.01 (9.88)
Module Area, m ² (ft ²)	0.56 (6.04)	0.56 (6.04)	0.56 (6.04)	0.56 (6.04)	0.56 (6.04)	0.56 (6.04)
Storage Efficiency ² m ³ /m ² , (ft ³ /ft ²)*	0.55 (1.80)	0.89 (2.92)	1.32 (4.32)	1.66 (5.45)	2.09 (6.85)	2.43 (7.97)

¹ Minimum finished grade to bottom of foundation stone

² Includes 6 in of foundation stone and 6 in of stone above the units at 40% void.

Module Selection Example:

Available area – 650.3 m² (7,000 ft²)
 Design Volume – 707.92 m³ (25,000 ft³)
 Min Finished Grade – 30.3 m (99.5 ft)
 Outlet Invert – 28.3 m (93 ft)

In this scenario, the system should be able to accommodate the minimum depth calculated as:

Minimum Depth
 30.3 m - 28.3 m = 2.0 m
 (99.5 ft - 93 ft = 6.5 ft)

With this it can be determined that either a 1 or 1.5 layer Aquabox system will fit the depth constraints.

The amount of volume that can be fit into the area is determined by dividing the design volume by the storage (m³/m² [ft³/ft²]) and checking it against the available area, for example:

Area Needed for 1 layer
 707.92/0.89 = 797.64 m²
 (25,000/4.32 = 5,788 ft²)

Area needed for 1 ½ layers
 707.92/1.32 = 536.30 m²
 (25,000/4.32 = 5,788 ft²)

Based on the available area of 650.3 m² (7,000 ft²) and the finished grade to outlet requirements the 1½ layer Aquabox system would be used for this project.

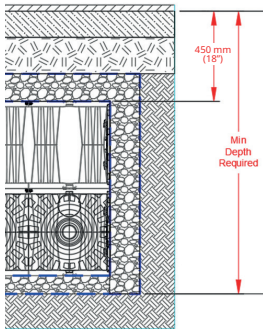

2.5 The Aquabox Maintenance Row

The Aquabox maintenance row is a row of Aquabox modules wrapped in filter fabric and connected to a closely located manhole for easy access. The fabric lined modules provide for sediment settling and filtration as stormwater rises in the Maintenance Row and passes through the filter fabric. The open structure of the modules allow stormwater to flow out the bottom and sides of the modules. Sediments are captured in the Aquabox Maintenance Row, protecting the storage volume in the rest of the modules from sediment accumulation.

ADS Plus fabric is used to wrap the Aquabox Maintenance Row. The woven geotextile provides a media for stormwater filtration, a durable surface for maintenance, prevents scour of the underlying stone and remains intact during high pressure jetting.

The Aquabox Maintenance Row is designed to capture the “first flush” runoff and offers the versatility to be sized on a volume basis or a flow-rate basis. An upstream manhole provides access to the Aquabox Maintenance Row and includes a high/low concept such that stormwater flow rates or volumes that exceed the capacity of the Aquabox Maintenance Row bypass through a manifold to the other modules. This is achieved with an elevated bypass manifold or a high-flow weir. After stormwater flows through the Aquabox Maintenance Row and into the rest of the Aquabox system it is either exfiltrated into the soils below or passed at a controlled rate through an outlet manifold and outlet control structure.

The Aquabox Maintenance Row may be part of a treatment train system. The treatment train design and pretreatment device selection by the design engineer is often driven by regulatory requirements. Whether pretreatment is used or not, ADS recommends using the Aquabox Maintenance Row to minimize maintenance requirements and maintenance costs.

Aquabox Isolator Row Standard Cross-Section

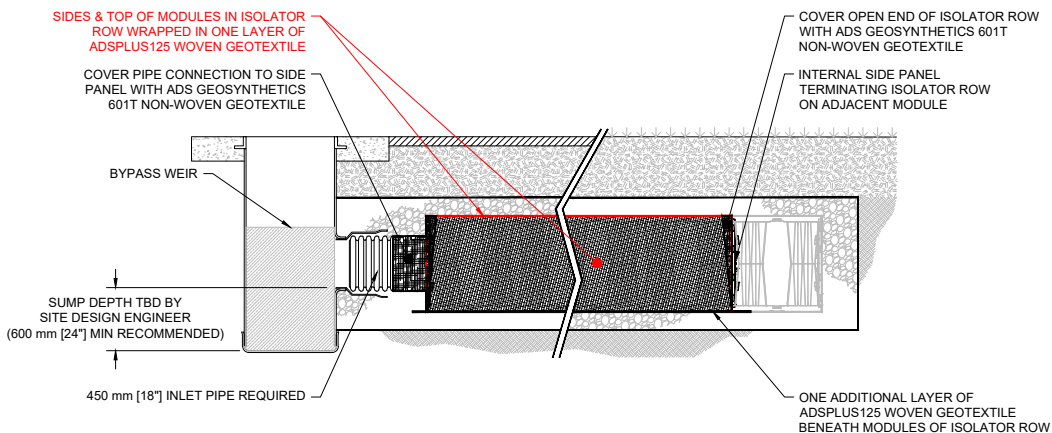

3.0 Structural Design

Verification of the Aquabox system structural integrity is carried out by checking the individual module capacity against vertical and lateral loads on the installed system. The evaluation is performed using the design practice outlined in CEN/TS 17152-4 *Guidance for Structural Design of Modular Systems*. The design practice is adapted to a North American context by using the AASHTO Design Truck as well as load factors from the AASHTO LRFD Bridge Design Specifications. The load calculations are described in the following sections.

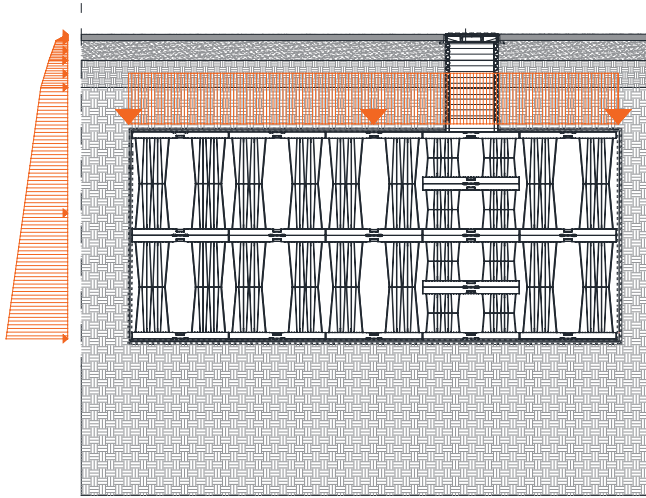

3.1 Vertical Load

Verification of the Aquabox module under vertical load is based on the soil load and the surface load expected for the project site.

3.1a Load Due to Soil Weight

For soil loading, the vertical pressure is calculated as a simple soil column where the density of the fill and the height of the fill are used to determine the soil pressure at the top surface of the system. Typically, a soil unit weight of 18.9 kN/m³ (120 pcf) is assumed unless otherwise specified by the design engineer.

3.1b Concentrated & Distributed Vertical Loads Due to Dead and Live Loads

For concentrated loads where a defined footprint area of the load is available, the load will distribute through the soil layers. The magnitude of distribution, and thereby reduction in the pressure at the top of the system, is a function of the load footprint, the angle of diffusion and the vertical distance between the load and the top of the Aquabox system.

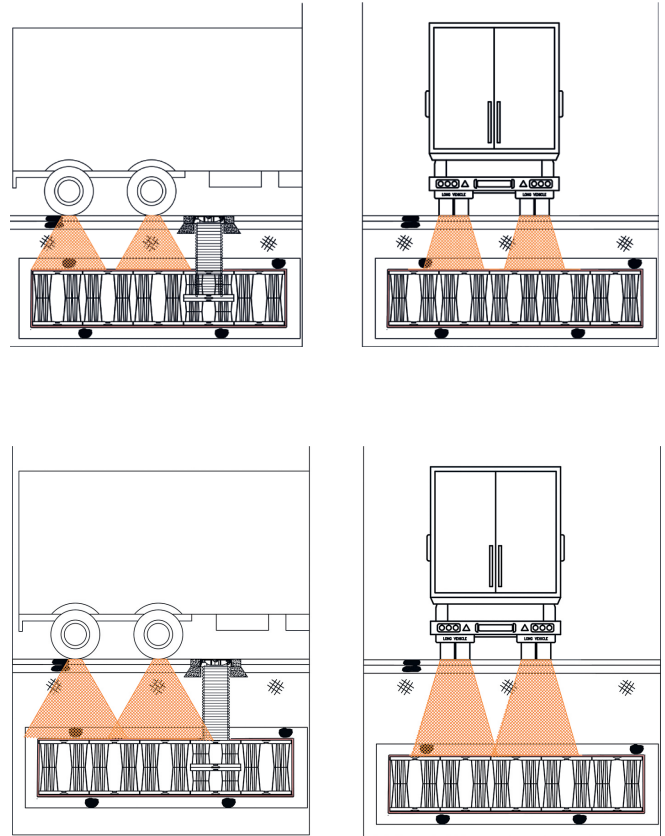

For vehicle loading, an additional impact factor is used to ensure adequate cover. The impact factor is calculated based upon the height of fill between the surface and the top of the Aquabox system. For minimum cover installations, the load is increased by up to 33% and will reduce as fill height increases.

3.2 Lateral Load

Verification of the Aquabox module under sidewall load is based on the soil load and the surface load expected for the project site.

3.2a Lateral Load Due to Soil Weight

The horizontal pressure due to soil load is a function of the soil density, soil layer height (measured from surface to bottom of excavation) and the active earth pressure coefficient of the soil adjacent to the system.

3.2b Lateral Load Due to Distributed Vertical Loads

The load distribution with increasing depth is provided by the analytical solution in terms of induced stresses and strains given by Boussinesq (1885).

The solution derived by Boussinesq's elastic problem for uniform pressure on a rectangular surface is the solution of Newmark (1942).

The general formula results in the different stress components in the different directions. The two components result in a load pressure (psf). By multiplying the pressure by the sidewall dimensions of the Aquabox module, the resulting force at a given depth is obtained.

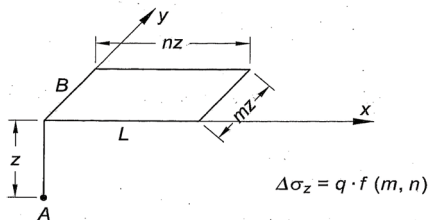

Depending on the direction, the component resulting in the highest load is always considered. This method is applied for calculating both dead and live loads. The minimum and maximum recommended cover heights listed previously take into account the worst-case stressed modules based on the variation of load pressure with burial depth.

3.3 Loads and Capacity Factors

The loads are then multiplied by respective factors following AASHTO LRFD Bridge Design Specifications, 9th edition.

Live load factor = 1.75

Vertical soil load factor = 1.95

Self-weight of product & accessories load factor = 1.30

Lateral soil load factor = 1.5

3.4 Uplift Check

The product should always be installed above the maximum piezometric level of the water table detected. For installations below the groundwater table, contact your ADS sales representative.

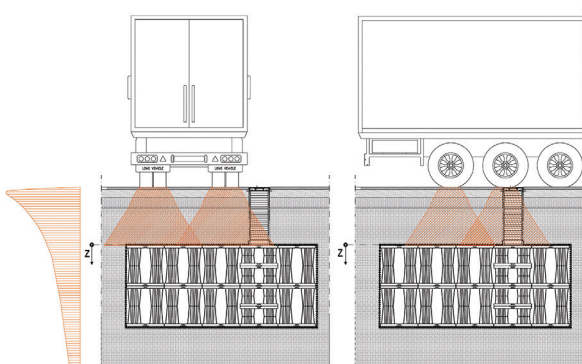

4.0 Aquabox System Installation

In new urbanized areas there must be proper planning of the maximum flows discharged into the receiving water systems compared to those existing before urbanization.

As a general rule, the water management system requires that the new flow generated by the urban modification is less than or equal to the pre-existing flow. In other cases, the new flow generated must be less than the maximum values allowed by the regulation or a maximum value accepted by the managing body of the receiving water body.

Aquabox modules allow for:

- Infiltration/retention
- Detention

4.1 Infiltration System

The Aquabox system allows for infiltration. The site soil and construction procedures will determine the amount of water infiltrated. Installation phases to create a dispersion trench with Aquabox are shown in the following chapter.

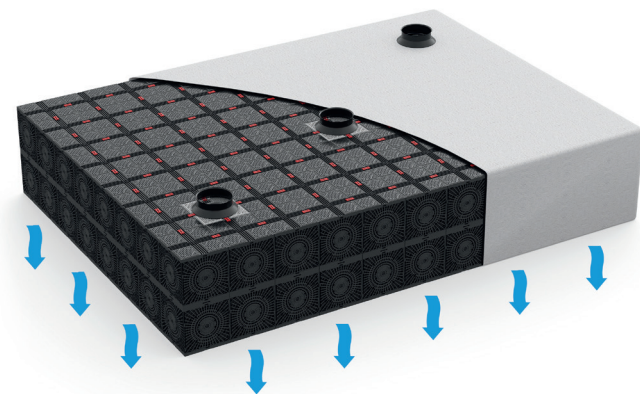

4.2 Preliminary Checks

To verify the suitability of the Aquabox system, it is suggested to carry out geotechnical and geological investigations on the installation site. The following conditions are suggested for assessment:

- Minimum distances from existing buildings and constructions
- Soil permeability
- Soil load capacity
- Maximum water table level

4.3 Excavation

Excavation must be made according to local design specifications. During the work, the walls of the excavation should be sloped or made in order to prevent any hazard to workers.

As a rule of thumb, a perimeter clearance of at least 300 mm (12") has to be provided between the plastic structure and the excavation wall.

In addition, the excavation must be maintained free of water during the entire installation phase.

4.4 Geotextile Installation

The excavation should be wrapped in geotextile to prevent migration of the native soils into the embedment stone.

Place nonwoven geotextile over the prepared subgrade and up the excavation walls. The geotextile must overlap at least 300 mm (12") on all edges.



The geotextile must meet these minimum standards:

Property	Test Method	Unit	M.A.R.V. (Minimum Average Roll Value)
Grab Tensile	ASTM	kN (lbs)	0.711 (160)
Grab Elongation	ASTM	%	50
Trapezoid Tear Strength	ASTM D4533	kN (lbs)	0.267 (60)
CBR Puncture Resistance	ASTM D6241	kN (lbs)	1.82 (410)
Permittivity	ASTM D4491	sec ⁻¹	1.5
Water Flow	ASTM D4491	l/min/m ² (gpm/ft ²)	4480 (110)
AOS*	ASTM D4751	mm (US Sieve)	0.212 (70)
Melting Point	ASTM D276	Celsius (Fahrenheit)	160 (320)
UV Resistance	ASTM D4355	hrs/%	70/500

4.5 Bedding Layer

For proper installation of Aquabox and Aquabox Cube modules, it is essential to create a flat and stable laying bed. For this purpose, a bedding layer of 150 mm (6") with crushed stone or fine gravel (approx. 9.4 - 25 mm [3/8"-1"] diameter) has to be created.

The quality of the bedding layer is important for module installation and the load-bearing and laying properties of the Aquabox system. This is particularly true for multilayer systems and high loads (soil and vehicle traffic loads).

4.6 Geotextile Wrap

A second layer of geotextile wrapping is used between the embedment stone and the Aquabox modules to prevent intrusion of the stone into the system.

Place this geotextile layer on the bedding stone layer before the installation of any Aquabox modules. The geotextile should have sufficient length to envelope the entire system and must overlap 300 mm (12") on all edges.

The geotextile must meet the requirements specified in section 4.4.

4.7 Aquabox Installation

Once the geotextile has been laid, the Aquabox modules can be installed.

Thanks to the easy connection system, each module can be preassembled without the use of cranes or mechanical means.

In fact, only slight pressure is needed to create a high-strength connection.

The pre-assembled modules must then be positioned, according to the design specifications.

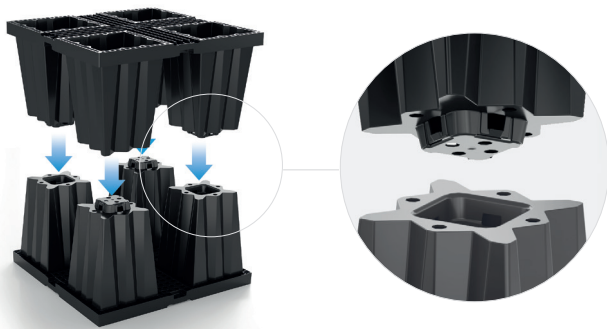

During installation, it is possible to walk on top of the modules. It is forbidden for operating machines, even small ones, to pass over the structure without proper covering.

Each Aquabox module is connected to the other by means of special connectors:

Single Joints:

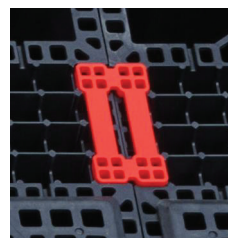

Joins modules on the top and bottom faces of the system (see photo)

Double Joints:

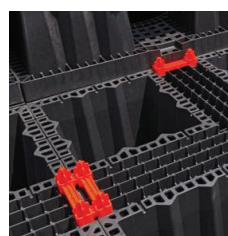

Joins modules at the intermediate layers of the system (see photo)

4.8 StormTech Isolator Row Plus

The StormTech Isolator Row Plus can be coupled with Aquabox modules as a premier water quality feature that captures sediment and provides easy access for inspection & maintenance. It is crucial to adhere to methods outlined in *Installation Guidance: StormTech Isolator Row Plus with Aquabox* for a safe and adequate installation.



4.9 Aquabox Maintenance Row

The Aquabox maintenance row is another water quality feature that can be used on Aquabox systems. The maintenance row provides a similar convenience to the StormTech Isolator Row Plus in a smaller footprint, offering a sediment capture solution on sites with challenging space constraints. Please adhere to installation guidance outlined in the *Aquabox O&M Manual* to ensure a safe & proper installation.

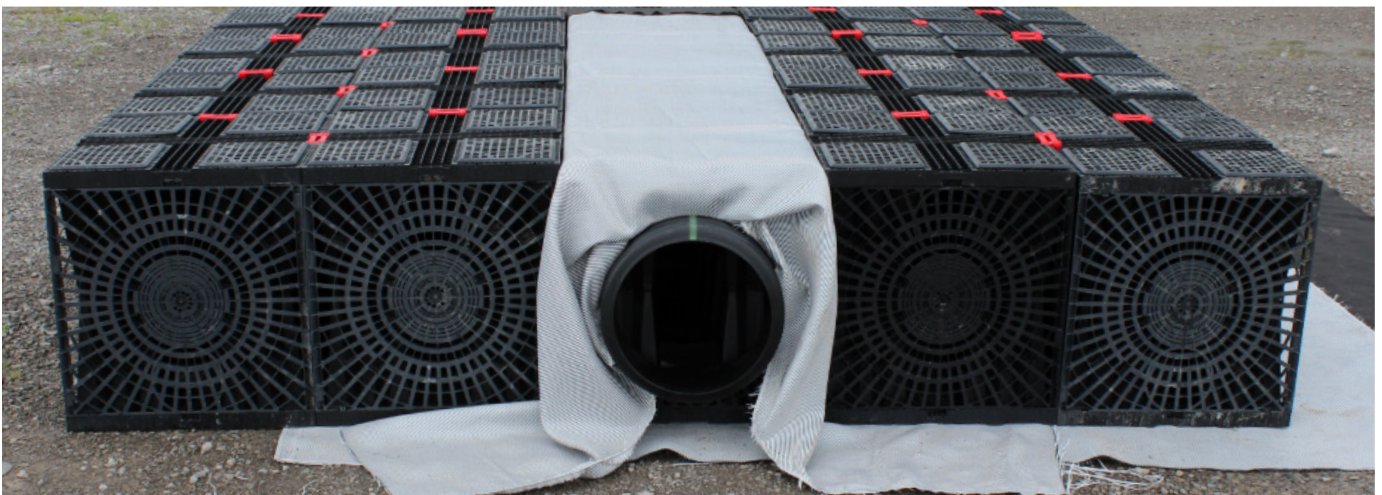

4.10 Aquabox Cube Installation

Aquabox Cube can be positioned within the Aquabox infiltration tank to provide additional inspection points within the system.

These Aquabox Cubes can be placed in any position in the system depending on the trench geometry and design requirements.

The Aquabox Cube shall be installed in the layout position according to design specifications.

Cube Positioning

The Aquabox Cube shaft can be placed in any point of the system, but are recommended to be placed internal to the perimeter.

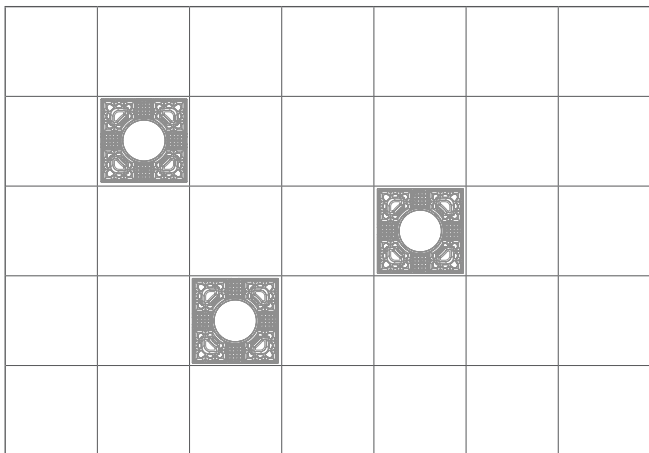

The Aquabox Cube has a central opening which enables a 300 mm (12") N-12 riser pipe to reach the surface. A Nyloplast inline drain finishes the top of the riser pipe.



- 1 Aquabox Cube installation
- 2 Joints installation
- 3 Final result

The Cap D4 is required for closing Aquabox Cube's opening on the bottom face of the lowest cube in the stack. D4 cap must be placed only on the bottom of the Cube.

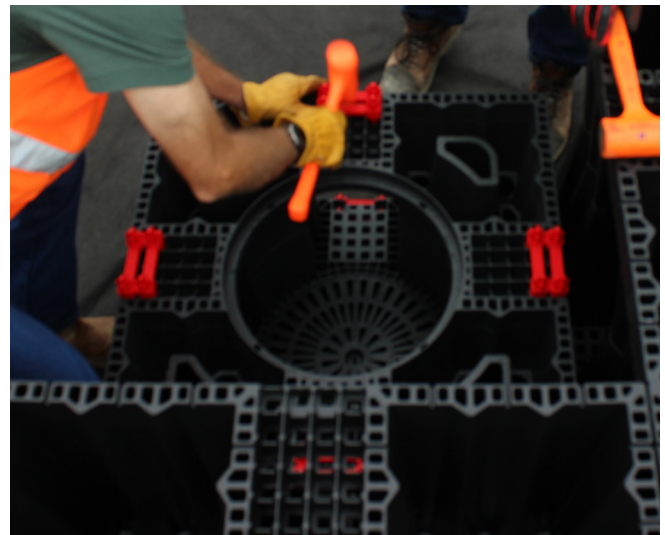

4.11 Installation of Sidewall & Top Caps

Sidewall grid and top caps are used to close the Aquabox system in all the perimeter (except the bottom face). This allows the distribution of the sidewall loads and the simple laying of geotextiles or waterproofing membranes.

In addition, the sidewall grids are designed to allow the connection of different pipe diameters for inflow and outflow.

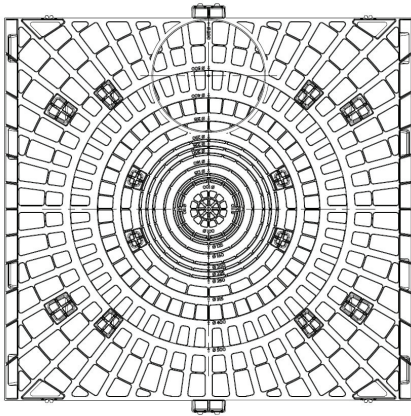

The top caps allow the top layer to be closed. As shown in the picture, installation is quick because of the clips' ease of use.

It is suggested to use a rubber mallet when installing the sidewall grid. Do not use an iron hammer.

The indications are the same for the Aquabox Cube sidewall grid, which allows the side closure of each individual module if the sump is installed along the perimeter.

The Aquabox Cube module has a unique top cap to accommodate the circular opening in the center of the module. Ensure that the Cube Module top caps are not being used with Full Modules.



4.12 Installation of Half Modules

Aquabox Half Modules are installed following the same general process as Full Modules, beginning once the geotextile has been placed. Each Half Module is assembled using two Half Bases and a single Full Module piece.

While the connection process is just as straightforward—requiring only light pressure for a secure fit—Half Modules are typically used in specialized conditions, such as shallow-depth applications. They should be installed according to project-specific layout plans, ensuring correct placement where a 0.5-layer configuration is needed.

As with Full Modules, installers may walk on the Half Modules during placement, however it's crucial that the modules are placed in the correct orientation. Walking on Half Modules installed upside down is advised against. No equipment should pass over the system without proper structural cover.

Aquabox Half Modules have unique sidewall parts that may be installed following the same guidelines as standard sidewall grids.

Top caps should also be installed in the same fashion as the Full Modules.

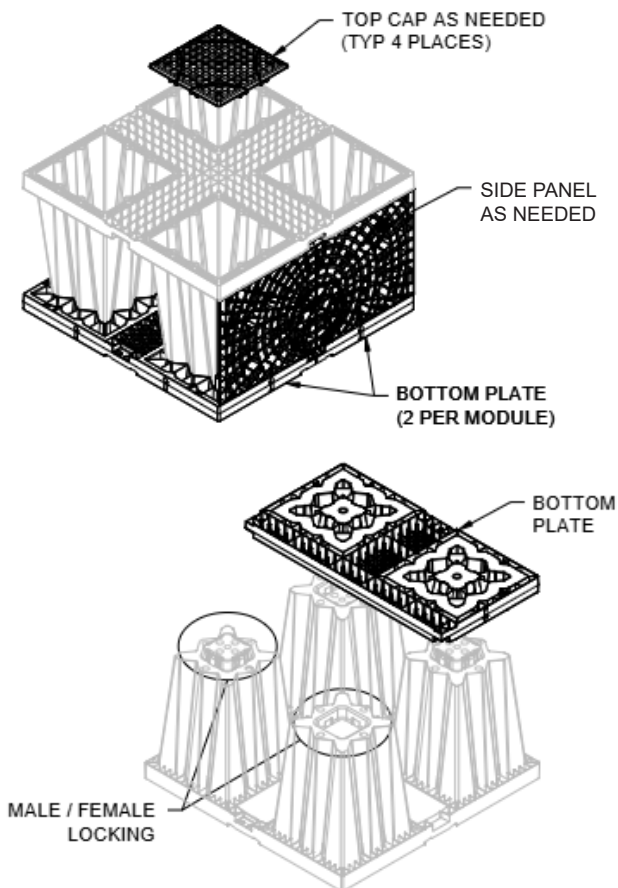

4.13 Covering with Geotextile

Complete wrapping of the Aquabox system side and top with nonwoven geotextile. This will complete the innermost envelope (see Section 4.6 for details).



4.14 Connections

The sizing of the collectors is the project designer's responsibility. The maximum pipe diameter that can be inserted into the sidewall grid is 450 mm (18").

Pipe is recommended to be inserted 150 mm (6"). Field cutting of pipe ends is required to achieve this insertion depth and prevent damage to the module. Refer to the construction guide for details.

Correct positioning of the pipe will occur due to the material gravel used for the side backfill (please pay special attention for this operation in order to keep the pipe on axis). We also recommend to skim the grate/pipe joint to enhance sealing.

4.15 Sidewall Backfilling

For sidewall backfill, it is recommended to use a non-cohesive material with maximum grain size 9.4 - 25 mm (3/8"-1") diameter.

Place backfill around the perimeter of the system in lifts of no more than 300 mm (12"). Each lift should be placed around the entire system such that backfill height does not differ by more than 300 mm (12") around the perimeter. The space between the structure and the edge of the excavation should be filled entirely with each lift.

Compaction of the sidewall backfill is not required. Do not operate compaction equipment or construction vehicles within 600 mm (24") of the edge of the Aquabox system during backfilling.

Do not begin placing fill over the system until the sidewalls are backfilled entirely.

Care should be taken to not damage the modules during backfill activities. Any damaged modules should be replaced before placing additional backfill.

Avoid damaging or displacing the geotextile during backfill.

4.16 Top Backfilling

For a typical Aquabox installation, finish placement of the embedment stone with a 150 mm (6") lift of gravel (grain size maximum 3/8" - 1") over the entire system. This lift does not need to be compacted. Only after 150 mm (6") of stone is in place can low-pressure tracked vehicles be used over the system for additional material placement and grading. Refer to the Aquabox Construction Guide for track pressure limits.

Then install a layer of nonwoven geotextile over the gravel layer as specified in Section 4.4.

Proceed next with placement and compaction of additional fill to the design grades and construction of the surface finish.



4.16 Equipment Allowed During Install

The first layer of cover can be laid using wheel loaders or small excavators. Attention must be taken with excavator or equipment during backfilling. For more information please refer to the Aquabox installation guide.



For further details, please consult Aquabox Installation Guide.

5.0 Inspection & Maintenance

Regular inspection and maintenance are essential to ensure a properly functioning stormwater system. The Isolator Row Plus & Aquabox maintenance row are techniques to inexpensively enhance Total Suspended Solids (TSS) removal with easy access for inspection and maintenance.

Inspection

The frequency of inspection and maintenance varies by location. A routine inspection schedule needs to be established for each individual location based upon site specific variables. The type of land use (i.e. industrial, commercial, residential), anticipated pollutant load, percent imperviousness, climate, etc. all play a critical role in determining the actual frequency of inspection and maintenance practices.

At a minimum, ADS recommends annual inspections. Initially, the Isolator Row Plus / maintenance row should be inspected every 6 months for the first year of operation. For subsequent years, the inspection should be adjusted based upon previous observation of sediment deposition.

The Isolator Row Plus / maintenance row should be inspected via the connecting pipe from the upstream structure. Mirrors on poles or cameras may be used to avoid a confined space entry. Inspection ports (optional) may be used for easy access to the system from the surface.

When the average depth of sediment exceeds 75 mm (3") throughout the row, clean-out should be performed.

Maintenance

The Isolator Row Plus and maintenance row were designed to reduce the cost of periodic maintenance. By "isolating" sediments to just one row, costs are dramatically reduced by eliminating the need to clean out all modules of the storage bed. If inspection indicates the potential need for maintenance, access is provided via a manhole(s) located on the end(s) of the row for cleanout. If entry into the manhole is required, please follow local and OSHA rules for a confined space entry.

Maintenance is accomplished with the JetVac process. The JetVac process utilizes a high pressure water nozzle to propel itself down the Isolator Row Plus / maintenance row while scouring and suspending sediments. As the nozzle is retrieved, the captured pollutants are flushed back into the manhole for vacuuming. Most sewer and pipe maintenance companies have vacuum/JetVac combination vehicles. Selection of an appropriate JetVac nozzle will improve maintenance efficiency. Rear facing jets with an effective spread of at least 45° are best. The minimum clear span within the Aquabox modules is 162.5 mm (6.5")--please ensure cleaning equipment does not exceed this width. ADS recommends a maximum nozzle pressure of 1750 psi be utilized during cleaning. JetVac reels can vary in length. For ease of maintenance, ADS recommends row lengths up to 46 m (150') with a structure at one end, or up to 91 m (300') with a structure at both ends.



6.0 Transport and Logistics

Aquabox modules are delivered stacked on pallets measuring 0.8 x 1.5 x 2.6 m (2.5' x 5' x 8.5').

A pallet contains 80 half Aquabox modules for a total of 40 modules. Thanks to the geometry of the product and its stackability, the total volume transported by a normal truck is equivalent to 460.1 m³ (16,250 ft³).

The sidewall grid and top cap are packed on separate pallets. The Aquabox Cube inspection components are stacked on separate pallets measuring 0.8 x 1.5 x 2.6 m (2.5' x 5' x 8'). These pallets are marked accordingly to distinguish them from other pallets.

Forklifts or cranes equipped with lifting straps can be used for unloading and handling pallets.

Once the modules have been removed from the pallet, pay attention to the following events:

- Improper storage (overlapping pallets, bulk stacking of modules)
- Improper handling (throwing the modules, dragging, etc.)
- Contact or impact with blunt or sharp objects.

Stackable

The modules are stackable and are delivered on pallets of 80 pieces that are equivalent to 18 m³ (636 ft³) each. The size of the packaging is: 0.8 x 1.5 x 2.6 m (2.5' x 5' x 8.5').

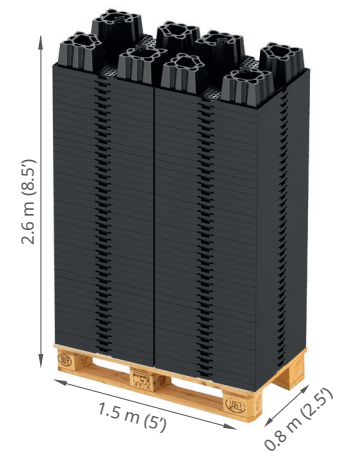
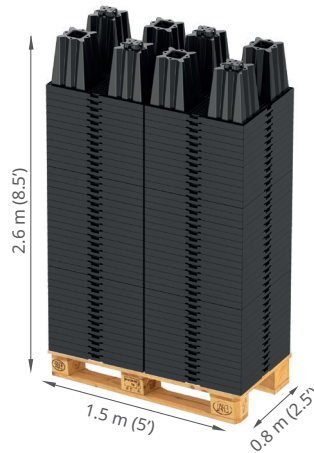

Easy installation

With the "Aqualock" overlapping system, two semi-modules are assembled together creating a cubic module ready to be placed in the excavation.

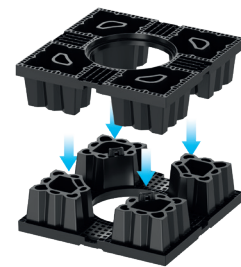
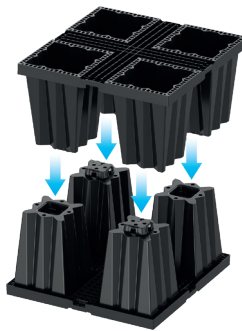

Ready to use

The modules once assembled are ready to be laid in the excavation for the creation of the system. The sidewall serves as fittings for the stormwater inlet/outlet pipes.

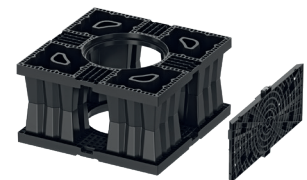
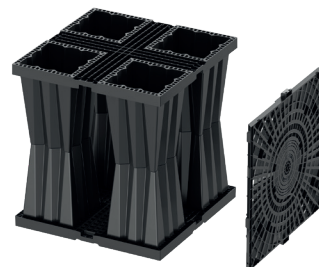



IMPORTANT: Before installation, check that the modules, sidewall grids, and top caps are not damaged or imperfect. Damaged parts must NOT be installed!



adspipe.ca

ADS "Terms and Conditions of Sale" are available on the ADS website, www.adspipe.ca.
Advanced Drainage Systems, the ADS logo, and the green stripe are registered trademarks of Advanced Drainage Systems, Inc.
©2026 Advanced Drainage Systems, Inc. #11163_C 02/26 AB

