

PEDESTRIAN GRATE INFORMATION

OPEN AREA, SQ IN (SQ CM)	OPEN AREA (%)	PRODUCT #
25.50 (165)	26.9	0520DIW

NOTES:

1. ALL DIMENSIONS ARE FOR REFERENCE ONLY
2. GRATE MEETS HS-25 LOAD RATING PER AASHTO M306-10
3. THE SIZE OF OPENINGS MEET THE REQUIREMENTS OF THE AMERICAN DISABILITY ACT, AS STATED IN FEDERAL REGISTER PART III, DEPARTMENT OF JUSTICE, 28 CFR PART 36

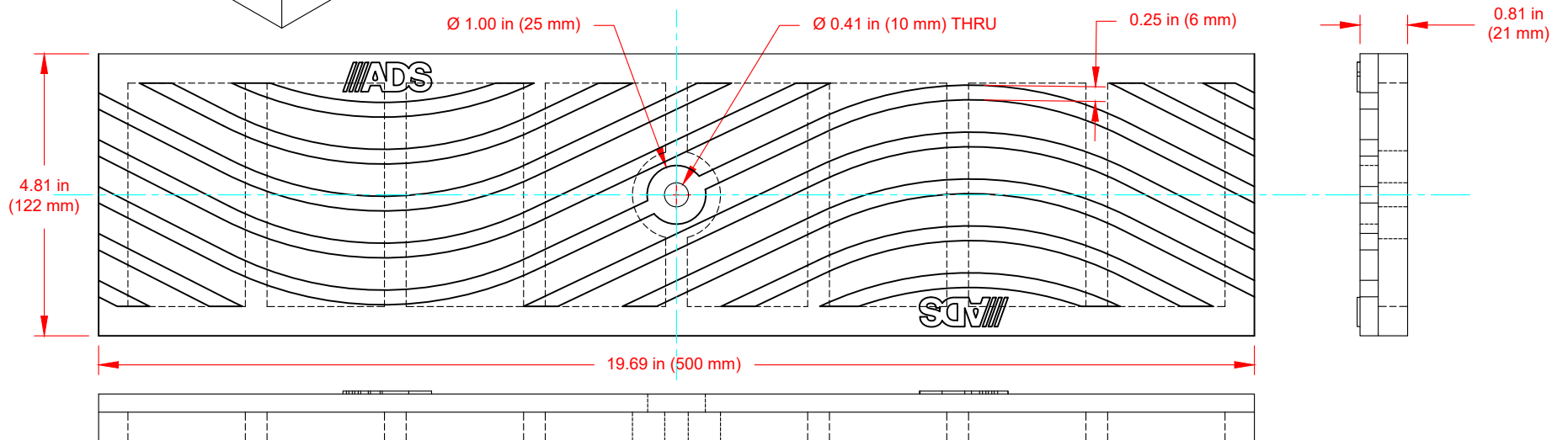

© 2025 ADS, INC.

2	Notes Update	KJS	01/30/25	-
REV.	DESCRIPTION	BY	MM/DD/YY	CHK'D

ADVANCED DRAINAGE SYSTEMS, INC. ("ADS") HAS PREPARED THIS DETAIL BASED ON INFORMATION PROVIDED TO ADS. THIS DRAWING IS INTENDED TO DEPICT THE COMPONENTS AS REQUESTED. ADS HAS NOT PERFORMED ANY ENGINEERING OR DESIGN SERVICES FOR THIS PROJECT, NOR HAS ADS INDEPENDENTLY VERIFIED THE INFORMATION SUPPLIED. THE INSTALLATION DETAILS PROVIDED HEREIN ARE GENERAL RECOMMENDATIONS AND ARE NOT SPECIFIC FOR THIS PROJECT. THE DESIGN ENGINEER SHALL REVIEW THESE DETAILS PRIOR TO CONSTRUCTION. IT IS THE DESIGN ENGINEERS RESPONSIBILITY TO ENSURE THE DETAILS PROVIDED HEREIN MEETS OR EXCEEDS THE APPLICABLE NATIONAL, STATE, OR LOCAL REQUIREMENTS AND TO ENSURE THAT THE DETAILS PROVIDED HEREIN ARE ACCEPTABLE FOR THIS PROJECT.

<b>Duraslot XL Pedestrian Grate</b>	
DRAWING NUMBER:	STD-1452



4640 TRUEMAN BLVD  
HILLIARD, OHIO 43026

DRAWN BY:	KJS
DATE:	04-18-2023
CHK'D BY:	-
SCALE:	NTS
SHEET:	1 OF 1