

- GENERAL NOTES
- THE DRAWINGS DEPICTED HEREIN REPRESENT PRELIMINARY LAYOUTS OF A WASTEWATER TREATMENT SYSTEM CAPABLE OF TREATING THE DOMESTIC WASTE CONSTITUENTS NOTED IN TABLE 1. COMMERCIAL OR NON-DOMESTIC WASTEWATER STREAMS ARE NOT INCLUDED IN THIS SCOPE AND MAY REQUIRE SEPARATE EVALUATION. CONTACT IWT FOR COMMERCIAL WASTEWATER TREATMENT REVIEW AND DESIGN REQUIREMENTS.
 - ECOPOD REACTOR BOX SHALL BE CONSTRUCTED OF HIGH DENSITY POLYETHYLENE (HDPE) OR AISI 304/304L STAINLESS STEEL.
 - TANK MATERIAL OPTIONS:
 - CARBON STEEL PER ASTM A36 w/COATING PER IWT STANDARDS.
 - FIBERGLASS REINFORCED PLASTIC (FRP) (NOT ALL MODELS).
 - PRECAST CONCRETE PER ENGINEER OF RECORD REQUIREMENTS, BY OTHERS.
 - CAST-IN-PLACE CONCRETE PER ENGINEER OF RECORD REQUIREMENTS, BY OTHERS.
 - BLOWERS, WEIRS, CONTROL PANELS, AND VARIOUS SMALL PARTS WILL BE SHIPPED UNASSEMBLED AND SECURELY PACKAGED, TO BE INSTALLED BY CONTRACTOR.
 - SEE INSTALLATION GUIDE FOR INSTALLATION DETAILS.
 - CONTACT AN IWT REPRESENTATIVE REGARDING DEVIATIONS FROM THESE STANDARDS.

PARAMETER	MINIMUM	MAXIMUM
AVERAGE DAILY FLOW	-	6,000 GPD
PEAK DAILY FLOW	-	9,000 GPD
INFLUENT BOD ₅	-	15 LB/DAY
AIR TEMPERATURE	-	115 °F
WATER TEMPERATURE	68 °F	68 °F
RELATIVE HUMIDITY	10%	90%
SITE ELEVATION	0 FT AMSL	3,000 FT AMSL

PARAMETER	UP TO 1,000 FT AMSL	1,000 TO 3,000 FT AMSL
STANDARD AIRFLOW	73 SCFM	85 SCFM
SITE AIR REQUIREMENT	82 ICFM	102 ICFM
BLOWER INLET AIR	116 ICFM	116 ICFM
AIR HEADER SIZE	3 IN	3 IN
MIN. TANK VENT X-SECT. AREA	47.7 IN ² 2 EA 6" OR 1 EA 8"	47.7 IN ² 2 EA 6" OR 1 EA 8"
BLOWER SELECTION	FPZ SCL K05-MS	FPZ SCL K05-MS
NOISE LEVEL	70.8 dB(A)	70.8 dB(A)
AIR TEMPERATURE RISE ¹	33 F (18.3 C)	33 F (18.3 C)
BLOWER INLET DIAMETER	2 IN NPT	2 IN NPT
BLOWER OUTLET DIAMETER	2 IN NPT	2 IN NPT
MOTOR POWER RATING ²	3 HP	3 HP
OPERATING POWER	1.7 KW	1.7 KW

1. REVIEW BLOWER DISCHARGE AIR TEMPERATURE WHEN SPECIFYING AIR MAIN PIPING MATERIAL.
2. REVIEW BLOWER MANUFACTURER CUTSHEETS FOR ADDITIONAL ELECTRICAL INFORMATION.

DESCRIPTION	QTY	MAKE	MODEL
ECOPOD REACTOR	1	IWT	E600D
BLOWER	1	FPZ	PER TABLE 2
CONTROL PANEL	1	IWT	PER DESIGN
24" S.S. EFFLUENT WEIR	1	IWT	TROUGH-3.0

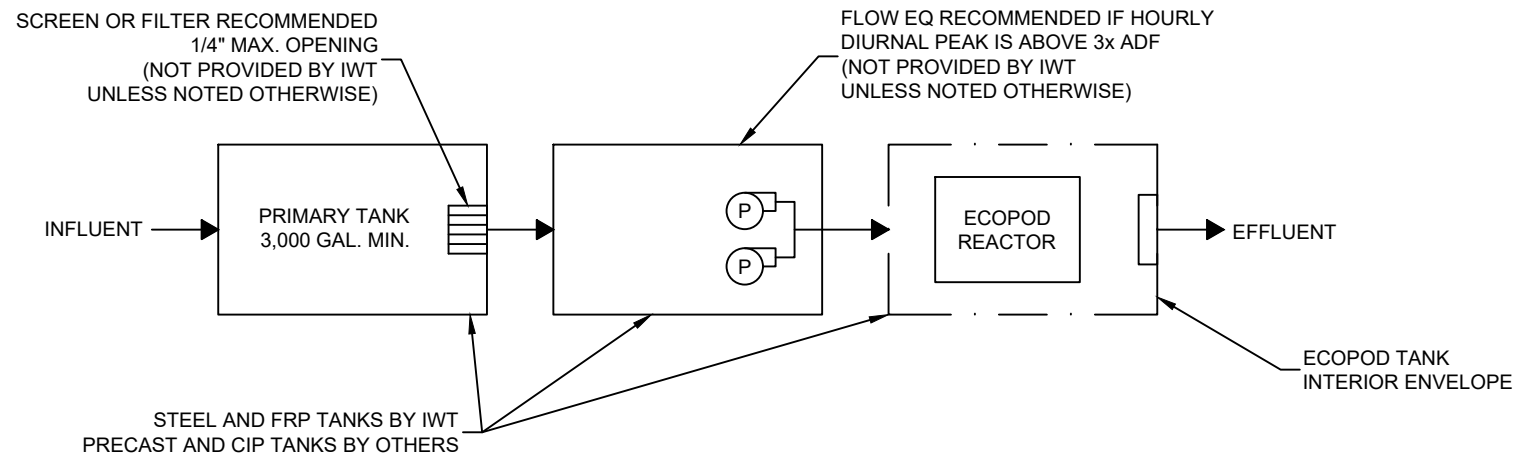

TYPICAL PROCESS DIAGRAM

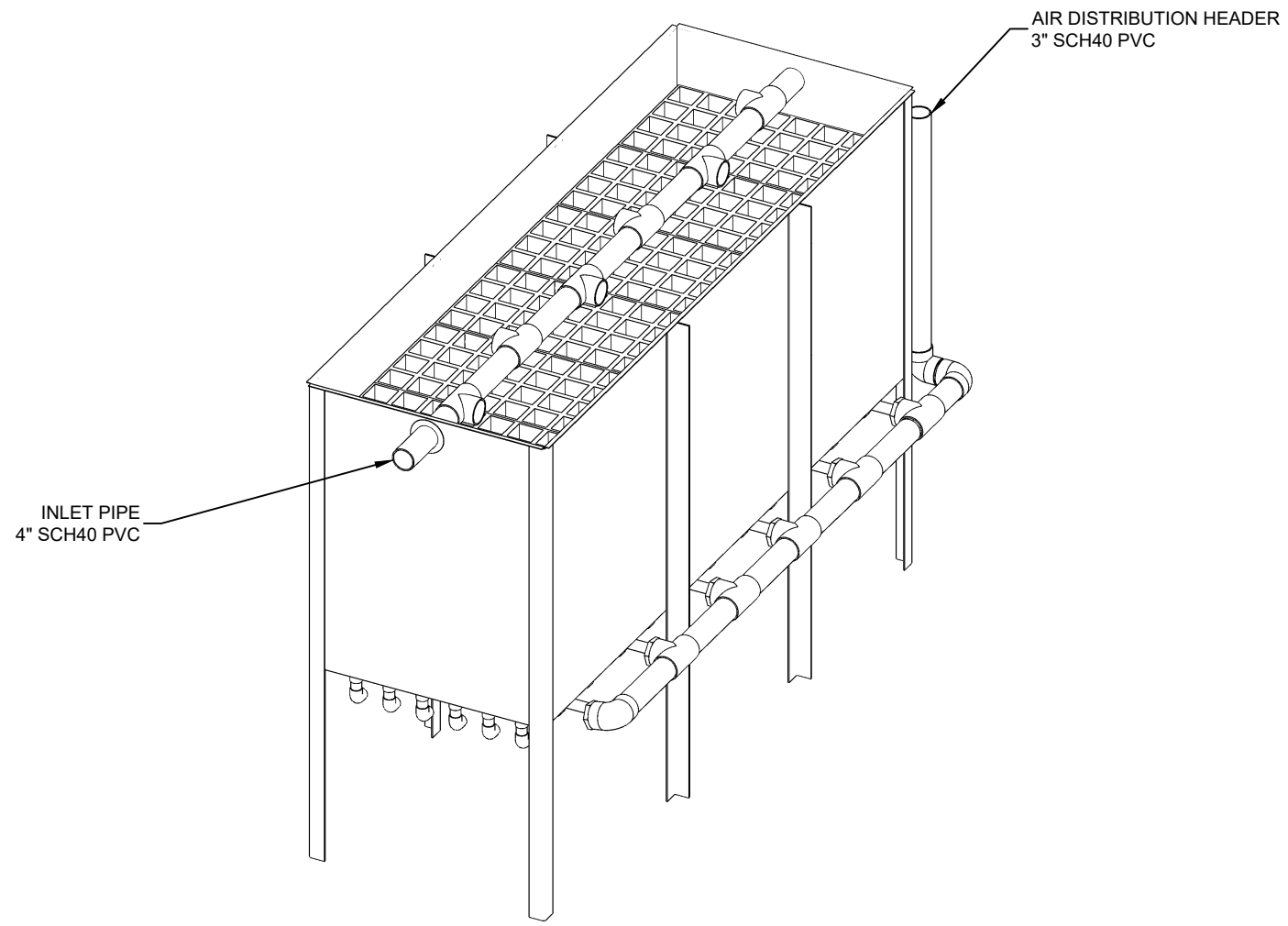

ECOPOD REACTOR LAYOUT 1

NO.	DATE	INITIALS	DESCRIPTION
A	10/12/21	AOB	ADDED TRIMETRIC VIEW

Infiltrator
Water Technologies
Part of ADS

INFILTRATOR WATER TECHNOLOGIES, LLC
4 BUSINESS PARK RD, OLD SAYBROOK, CT 06475
WWW.INFILTRATORWATER.COM
PHONE: (800) 221-4436 / EMAIL: INFO@INFILTRATORWATER.COM

COPYRIGHT (C) 2024 INFILTRATOR WATER TECHNOLOGIES, LLC (IWT). INFORMATION CONTAINED HEREIN IS CONFIDENTIAL AND IS THE PROPERTY OF IWT. NO PART OF THIS DRAWING SHALL BE REPRODUCED, DISTRIBUTED, DISCLOSED, OR USED BY ANY PERSON OR ORGANIZATION, IN WHOLE OR IN PART, WITHOUT THE PRIOR WRITTEN PERMISSION OF IWT. THIS INFORMATION IS BASED ON SPECIFIC INPUT PARAMETERS AND IS FOR BUDGETARY OR PRELIMINARY USE ONLY. USE AND INTERPRETATION OF THIS INFORMATION AND DETERMINING THE APPLICABILITY TO A SPECIFIC PROJECT IS AT THE SOLE DISCRETION OF THE USER AND/OR THE ENGINEER OF RECORD.

ECOPOD E600D
STANDARD DESIGN FOR BOD REDUCTION

GENERAL ARRANGEMENT
DESIGN OVERVIEW

HORIZ. SCALE	PROJECT NO.
N/A	N/A
VERT. SCALE	DATE
N/A	02/11/2021
DRAWN BY	DESIGNED BY
CGK	AOB
DRAWING NO.	SHEET NO.
C1.0	01 of 02

GENERAL NOTES

- THE DRAWINGS DEPICTED HEREIN REPRESENT PRELIMINARY LAYOUTS OF A WASTEWATER TREATMENT SYSTEM CAPABLE OF TREATING THE DOMESTIC WASTE CONSTITUENTS NOTED IN TABLE 1. COMMERCIAL OR NON-DOMESTIC WASTEWATER STREAMS ARE NOT INCLUDED IN THIS SCOPE AND MAY REQUIRE SEPARATE EVALUATION. CONTACT IWT FOR COMMERCIAL WASTEWATER TREATMENT REVIEW AND DESIGN REQUIREMENTS.
- ECOPOD REACTOR BOX SHALL BE CONSTRUCTED OF HIGH DENSITY POLYETHYLENE (HDPE) OR AISI 304/304L STAINLESS STEEL.
- TANK MATERIAL OPTIONS:
 - CARBON STEEL PER ASTM A36 w/COATING PER IWT STANDARDS.
 - FIBERGLASS REINFORCED PLASTIC (FRP) (NOT ALL MODELS).
 - PRECAST CONCRETE PER ENGINEER OF RECORD REQUIREMENTS, BY OTHERS.
 - CAST-IN-PLACE CONCRETE PER ENGINEER OF RECORD REQUIREMENTS, BY OTHERS.
- BLOWERS, WEIRS, CONTROL PANELS, AND VARIOUS SMALL PARTS WILL BE SHIPPED UNASSEMBLED AND SECURELY PACKAGED, TO BE INSTALLED BY CONTRACTOR.
- SEE INSTALLATION GUIDE FOR INSTALLATION DETAILS.
- CONTACT AN IWT REPRESENTATIVE REGARDING DEVIATIONS FROM THESE STANDARDS.

SITE ELEVATION		LAYOUT ID	REACTOR WEIGHT		A OVERALL LENGTH		B OVERALL WIDTH		B1 AIR HEADER CL DIM	
FT	M		LB	KG	IN	CM	IN	CM	IN	CM
0-3,000	0-914	1	1,580	718	154	392	59	150	32	82
0-3,000	0-914	2	1,430	649	93	237	107	272	56	143
0-1,000	0-305	3	1,450	658	106	270	83	211	44	112

1. SOME REACTOR LAYOUTS NOT AVAILABLE IN FIBERGLASS TANKS. CONTACT AN IWT REPRESENTATIVE FOR DETAILS.

DIMENSION	IN	CM
C VESSEL FRONT SPACE	12	30
D VESSEL REAR SPACE	18	46
E AIR HEADER SIDE INSIDE SPACE	6	15
F NO HEADER SIDE INSIDE SPACE	6	15

1: ADDITIONAL ACCESS HATCHES RECOMMENDED FOR SOLIDS REMOVAL ALONG VESSEL SIDES.

DIMENSION	IN	CM
G INLET INVERT	92	234
H PLENUM SPACE ABOVE INLET INVERT	10	25
J MEDIA REACTOR HEIGHT	101	257
K OUTLET INVERT	89	226

1. ONE (1 EA.) INLET AND ONE (1 EA.) OUTLET ACCESS HATCH REQUIRED, 24" DIA MINIMUM.

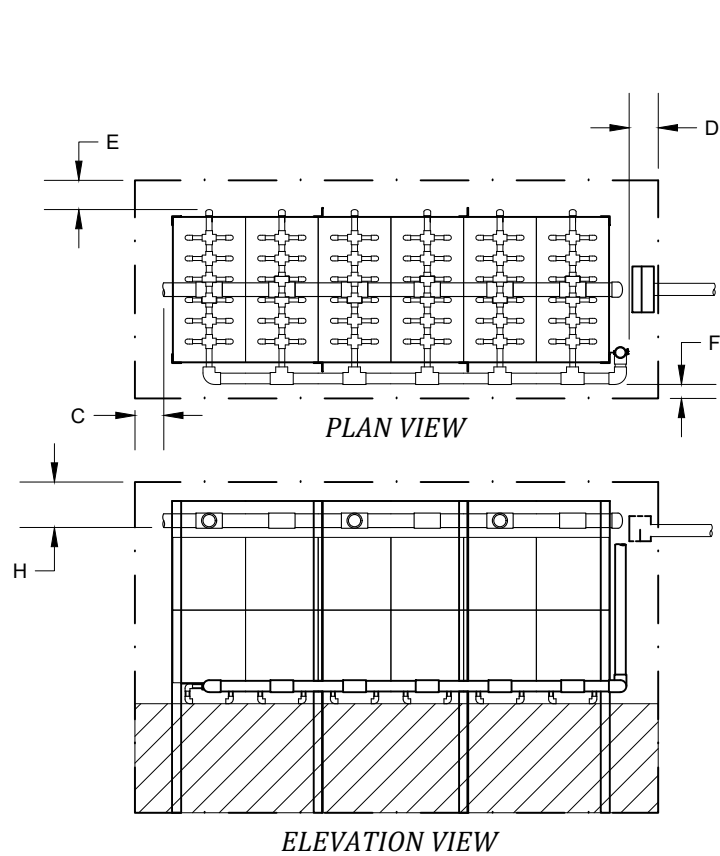

LAYOUT 1

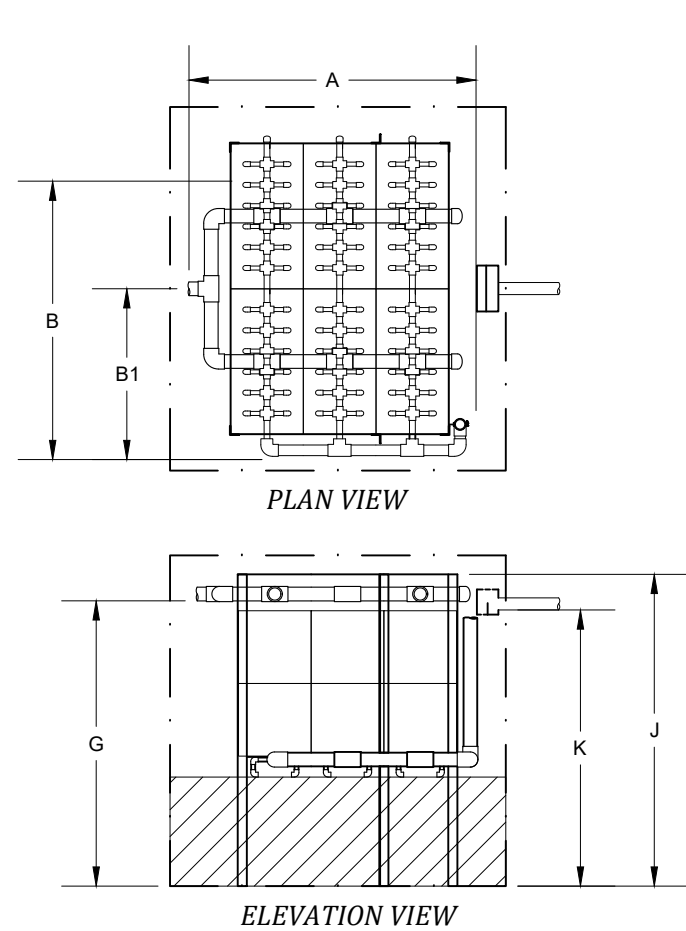

LAYOUT 2

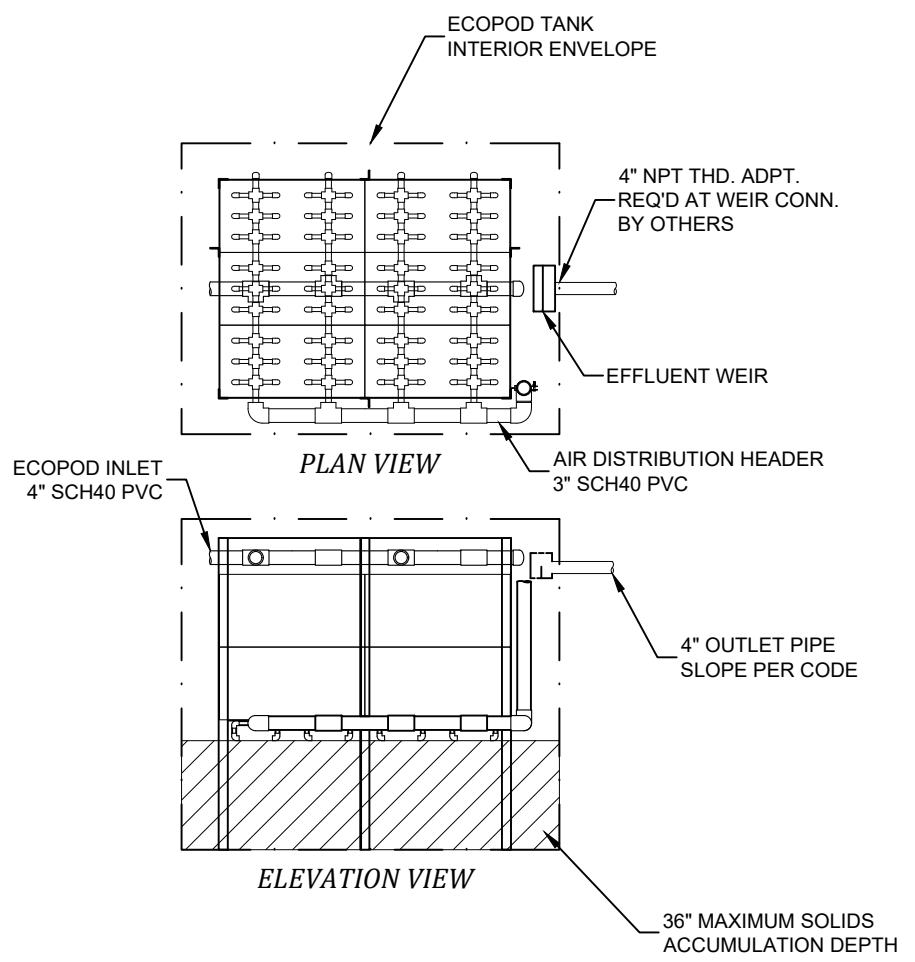

LAYOUT 3

NO.	DATE	INITIALS	DESCRIPTION

Infiltrator
Water Technologies
Part of ADS

INFILTRATOR WATER TECHNOLOGIES, LLC
4 BUSINESS PARK RD, OLD SAYBROOK, CT 06475
WWW.INFILTRATORWATER.COM
PHONE: (800) 221-4436 / EMAIL: INFO@INFILTRATORWATER.COM

COPYRIGHT (C) 2024 INFILTRATOR WATER TECHNOLOGIES, LLC (IWT). INFORMATION CONTAINED HEREIN IS CONFIDENTIAL AND IS THE PROPERTY OF IWT. NO PART OF THIS DRAWING SHALL BE REPRODUCED, DISTRIBUTED, DISCLOSED, OR USED BY ANY PERSON OR ORGANIZATION, IN WHOLE OR IN PART, WITHOUT THE PRIOR WRITTEN PERMISSION OF IWT. THIS INFORMATION IS BASED ON SPECIFIC INPUT PARAMETERS AND IS FOR BUDGETARY OR PRELIMINARY USE ONLY. USE AND INTERPRETATION OF THIS INFORMATION AND DETERMINING THE APPLICABILITY TO A SPECIFIC PROJECT IS AT THE SOLE DISCRETION OF THE USER AND/OR THE ENGINEER OF RECORD.

ECOPOD E600D
STANDARD DESIGN FOR BOD REDUCTION

GENERAL ARRANGEMENT
LAYOUT DIMENSIONS

HORIZ. SCALE	PROJECT NO.
N/A	N/A
VERT. SCALE	DATE
N/A	05/19/2021
DRAWN BY	DESIGNED BY
CGK	AOB
DRAWING NO.	SHEET NO.
C1.1	02 of 02

C:\Users\kenneth.mckinnon\Desktop\Drawings\ECOPOD\ECOPOD STD\FINAL\DWG\ECOPOD STD\COMMERCIAL\Standard Commercial EcoPod Drawings Rev D.dwg