

# Engineered Drainage for Railway Applications

---



# The Standard in Drainage Pipe

## N-12® HDPE and HP Storm Pipe

Advanced Drainage Systems has built a reputation for economy, durability and superior performance in gravity-flow storm drainage applications. Advances in polymer science and structural design have created a product that has outperformed and outlasted many traditional pipe products, while maintaining its cost advantage.

ADS introduced the first High Density Polyethylene (HDPE) drainage pipe to combine an annular corrugated exterior for strength with a smooth interior wall for maximum flow capacity. In 2007, ADS engineered higher stiffness pipe using polypropylene (PP) to enhance wall and joint performance. The quality upgrades and performance history of these systems have led to rapid acceptance of HDPE and PP pipes by contractors, engineers, municipalities and state agencies.

## Revolutionary Joining Technology

Years of research and testing have produced a fast-coupling, watertight bell-and-spigot joint. A proprietary gasket design maximizes sealing, which meets ASTM F477 standards. The gasket is factory installed into the spigot to speed installation. The result is a design that meets or exceeds ASTM D3212 lab test and ASTM F2487 watertight field test requirements. The design also fills an essential role in complying with the stricter demands of EPA guidelines.

## Applications

N-12 pipe meets the requirements of ASTM F2306, AASHTO M252 or M294 Type S. HP Storm meets the requirements of ASTM F2881 and AASHTO M330. These products have been specified under railroads, airports, interstates, and defense projects for culverts, storm drains, and sanitary applications.

## Structural Strength

As a flexible conduit, high density polyethylene & polypropylene pipes withstand vertical pressure by transferring most of the load to the surrounding soil. N-12 and HP Storm pipes will support Cooper E-80 live loads with as little as 2' (600 mm) of cover for 24" (600 mm) and smaller diameter pipe, 3' (900 mm) of cover for 30" (750 mm) and 36" (900 mm) diameter pipe and 4' (1200 mm) of cover for 48" (1200 mm) and larger diameter pipes. Field research done in Ohio and Pennsylvania has placed high density polyethylene pipe and polypropylene pipes under more than 40' (12 m) of fill. Even under harsh climatic and soil conditions, high density polyethylene and polypropylene pipes have continued to give outstanding performance. Testing at Transportation Technology Center, Inc. (TTCI) in Pueblo, Colorado and design calculations support engineered loading conditions.

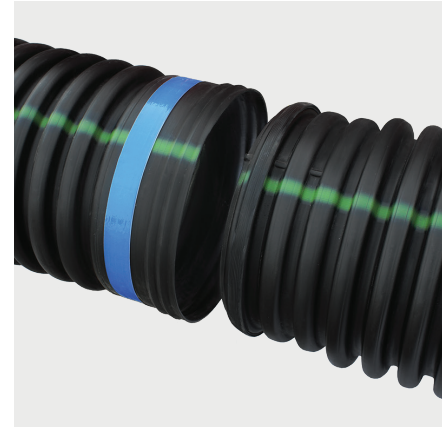

N-12 Pipe

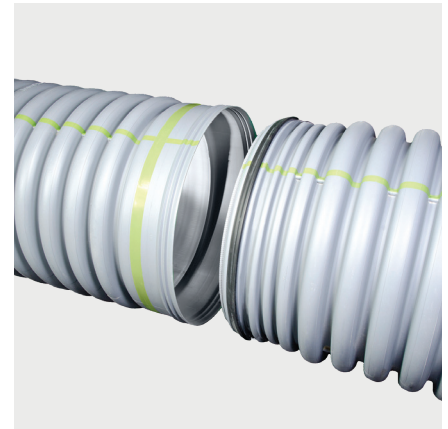

HP Storm Pipe

# Railway Installation Typical Trench Detail STD-107C

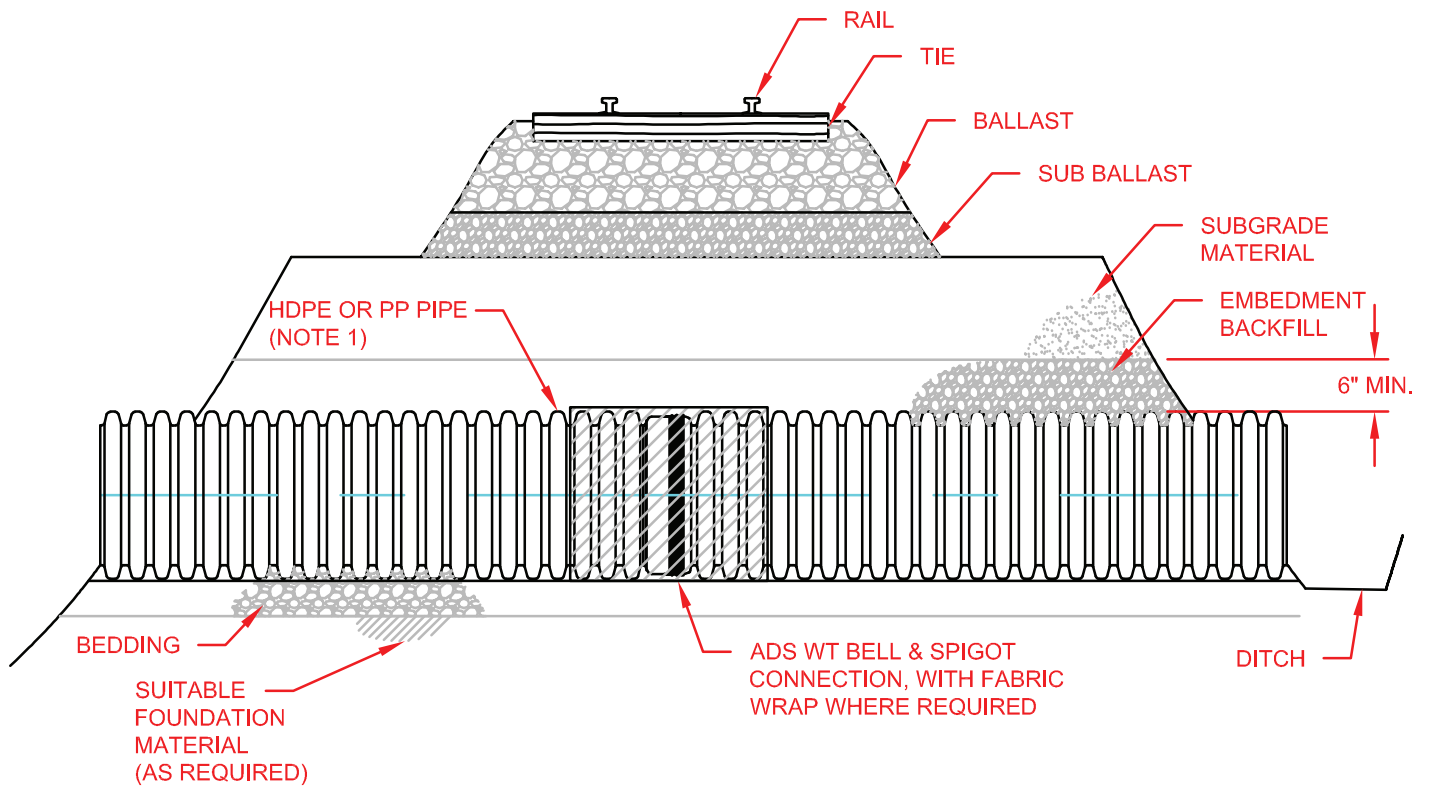

## NOTES:

1. HIGH DENSITY POLYETHYLENE PIPE SHALL MEET AASHTO M294 OR ASTM F2306. DUAL WALL POLYPROPYLENE PIPE SHALL MEET AASHTO M330 (TYPE S) AND ASTM F2881.
2. ALL PIPE SYSTEMS SHALL BE INSTALLED IN ACCORDANCE WITH ASTM D2321, "STANDARD PRACTICE FOR UNDERGROUND INSTALLATION OF THERMOPLASTIC PIPE FOR SEWERS AND OTHER GRAVITY FLOW APPLICATIONS", LATEST ADDITION.
3. MEASURES SHOULD BE TAKEN TO PREVENT MIGRATION OF NATIVE FINES INTO BACKFILL MATERIAL, WHEN REQUIRED. ALL OPEN-GRADED (POORLY GRADED) BACKFILL SHALL BE WRAPPED WITH 8 OZ. (MINIMUM) WOVEN GEOTEXTILE FABRIC AND MEETS ENGINEER'S RECOMMENDATIONS.
4. **FOUNDATION:** WHERE THE TRENCH BOTTOM IS UNSTABLE, THE CONTRACTOR SHALL EXCAVATE UNSUITABLE MATERIAL TO THE REQUIRED DEPTH AND REPLACE WITH SUITABLE MATERIAL AS SPECIFIED BY THE DESIGN ENGINEER. DEPTH OF FOUNDATION IMPROVEMENT MAY BE REDUCED BY USE OF GEOTEXTILE FABRIC AND GRID. REQUIRED TRENCH WIDTH MAY INCREASE WHEN FOUNDATION MATERIAL IS MODIFIED.
5. **BEDDING:** SUITABLE MATERIAL SHALL BE ASTM D2321 CLASS I OR II. MINIMUM BEDDING THICKNESS SHALL BE 4" (100mm) FOR 12"-24" (300mm-600mm); 6" (150mm) FOR 30"-60" (750mm-1500mm). THE MIDDLE THIRD OF THE BEDDING SHALL BE LOOSE AND UNIFORM IN DEPTH AND CONSISTANCY. AFTER PIPE IS IN PLACE, COMPACT BEDDING TO EMBEDMENT BACKFILL STANDARDS.
6. **EMBEDMENT BACKFILL:** SUITABLE MATERIAL SHALL BE ASTM D2321 CLASS I OR II UNLESS STATED OTHERWISE BY THE DESIGN ENGINEER. MINIMUM COMPACTION SHALL BE:  
  
CLASS I, COMPACT IN PLACE, 8" LOOSE LIFTS WITH JUMPING JACK OR SMALL VIBRATORY COMPACTOR  
CLASS II, COMPACT IN PLACE, 8" LOOSE LIFTS TO MIN. 95% STANDARD PROCTOR DENSITY
7. THE CONTRACTOR SHOULD PROVIDE DOCUMENTATION FOR MATERIAL SPECIFICATIONS TO DESIGN ENGINEER.
8. AS BACKFILL IS BEING PLACED, WORK BACKFILL INTO HAUNCH ZONE BY SHOVELING IN PLACE AND DIAGONALLY WALKING (STOMPING) THE SOIL INTO THE HAUNCH ZONE. THIS EFFORT WILL MAKE VERTICAL COMPACTION MORE EFFECTIVE.

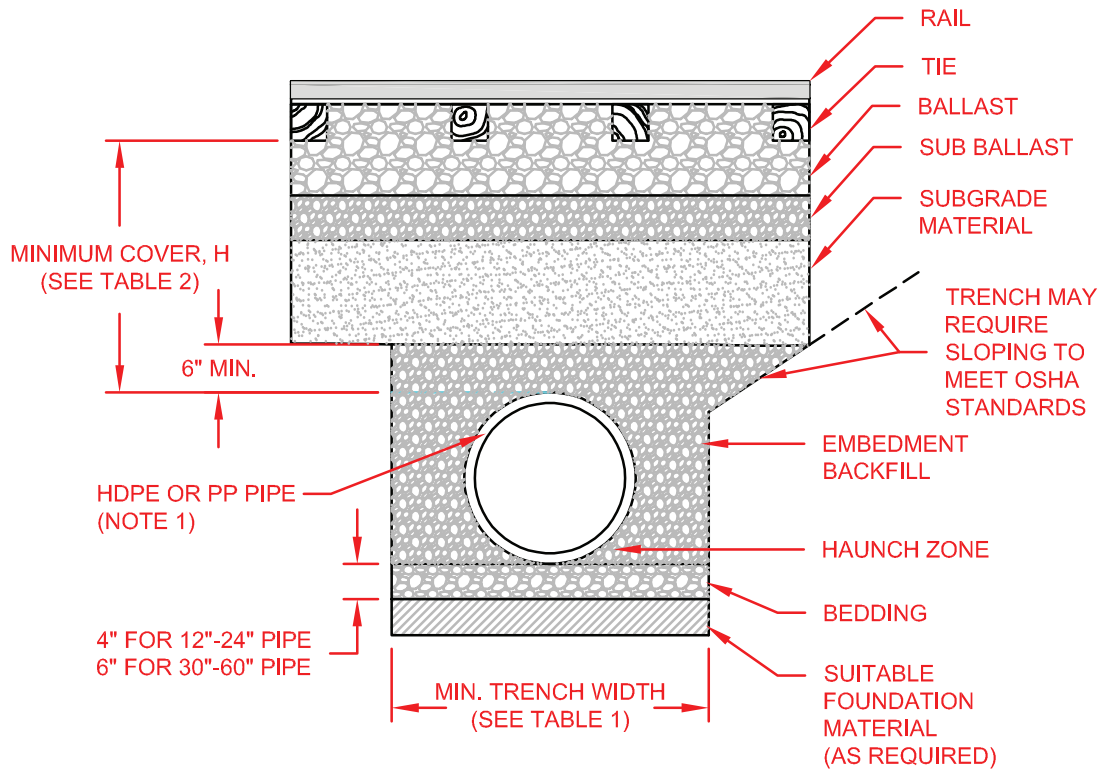

**TABLE 1**  
RECOMMENDED MINIMUM TRENCH WIDTHS

PIPE DIAM.	MIN. TRENCH WIDTH
4" (100mm)	21" (533mm)
6" (150mm)	23" (584mm)
8" (200mm)	26" (660mm)
10" (250mm)	28" (711mm)
12" (300mm)	30" (762mm)
15" (375mm)	34" (864mm)
18" (450mm)	39" (991mm)
24" (600mm)	48" (1219mm)
30" (750mm)	56" (1422mm)
36" (900mm)	64" (1626mm)
42" (1050mm)	72" (1829mm)
48" (1200mm)	80" (2032mm)
60" (1500mm)	96" (2438mm)

4"-10" ONLY AVAILABLE  
FOR HDPE

**TABLE 2**  
MINIMUM RECOMMENDED COVER<sup>1,3</sup> BASED  
ON RAILWAY LOADING CONDITIONS

PIPE DIAM.	COOPER E-80 <sup>2</sup>
UP TO 24" (600mm)	24" (610mm)
30" - 36" (750mm-900mm)	36" (914mm)
42" - 60" (1050mm-1500mm)	48" (1219mm)

- COVER IS MEASURED FROM TOP OF PIPE TO BOTTOM OF RAILWAY TIE.
- LOADS GREATER THAN E-80 LOAD MAY REQUIRE ADDITIONAL COVER.
- MINIMUM COVER MAY BE INCREASED TO PREVENT PIPE DAMAGE DUE TO ROUTINE TRACK MAINTENANCE.

# Superior Pipe Materials

## Durability

High density polyethylene and polypropylene pipes are extremely tough materials that can easily withstand the normal impacts involved in shipping, installation and service. Both are highly resistant to corrosion and chemical attack and are unaffected by soils or effluents with pH ranges from 1.5 to 14. (Please refer to Technical Note 4.01 and 4.02 for chemical resistance charts of the materials. Technical Notes found on the ADS website at [www.ads-pipe.com](http://www.ads-pipe.com) in the Technical Notes section under the Drainage Handbook menu.) Also, since high density polyethylene and polypropylene materials are not conductive, N-12, HP Storm, and SaniTite HP remain unaffected by electrochemical corrosion or stray electrical currents that may otherwise adversely affect other pipe materials.

High density polyethylene's and polypropylene's ductility and molecular structure result in excellent resistance to abrasion. Polyethylene and polypropylene pipes show less than 20% material loss when compared to competing materials in abrasive environments, and is often specified for harsh mine slurries and as a slip liner for deteriorated culverts.

## Hydraulic Efficiency

The smooth interior of N-12, HP Storm, and SaniTite HP pipes provide superior flow characteristics. Laboratory tests show that a Manning's roughness coefficient of 0.012 is appropriate when designing with N-12, HP Storm, and SaniTite HP pipes.

## Lightweight

High density polyethylene and polypropylene pipes are lighter than traditional pipes, making it far easier to transport and handle. On-site labor and equipment requirements are reduced, with a corresponding reduction in the potential risk of injury.

## Fast Installation

Polyethylene and polypropylene pipes have been installed up to 2x faster than pipe made from competitive materials. The lightweight nature of the pipe, 20' (6 m) long sections, gasketed inline bell and spigot joints which are easily assembled and cuts that can be made quickly add up to quality and fast installations. As with all pipes it is important to properly place and use backfill material that will produce a pipe-soil interaction system capable of withstanding the applied loads. Instructions for underground installation of plastic drainage pipe are contained in ASTM D2321. Specific supplemental instructions for N-12, HP Storm and SaniTite HP pipes in railroad applications are found in this brochure.

## Fittings

For underdrain applications, 4"-12" (100-300 mm) injection molded fittings are approved for under track (Cooper E-80) applications. Larger diameter fittings are available for both polyethylene (HDPE) and polypropylene (PP) pipe for non-track applications. Please consult an ADS Engineering Representative if fittings greater than 12" (300 mm) diameter are required under track applications to ensure suitability.

## Under Drains

Polyethylene and propylene pipes with Class II perforations per AASHTO M252, M294 and M330, when backfilled with ASTM D2321 Class I (walking or yard ballast), provide an exceptional underdrain system. Pipes with a Type "S" profile provide a smooth interior, which minimizes siltation and facilitates cleaning. The 20' (6 m) sections aid in setting pipes to proper line and grade. In areas where rodents may nest in pipes, rodent protection is suggested at the end of all outlet pipes. Guidance for underdrains in trench applications is shown below.

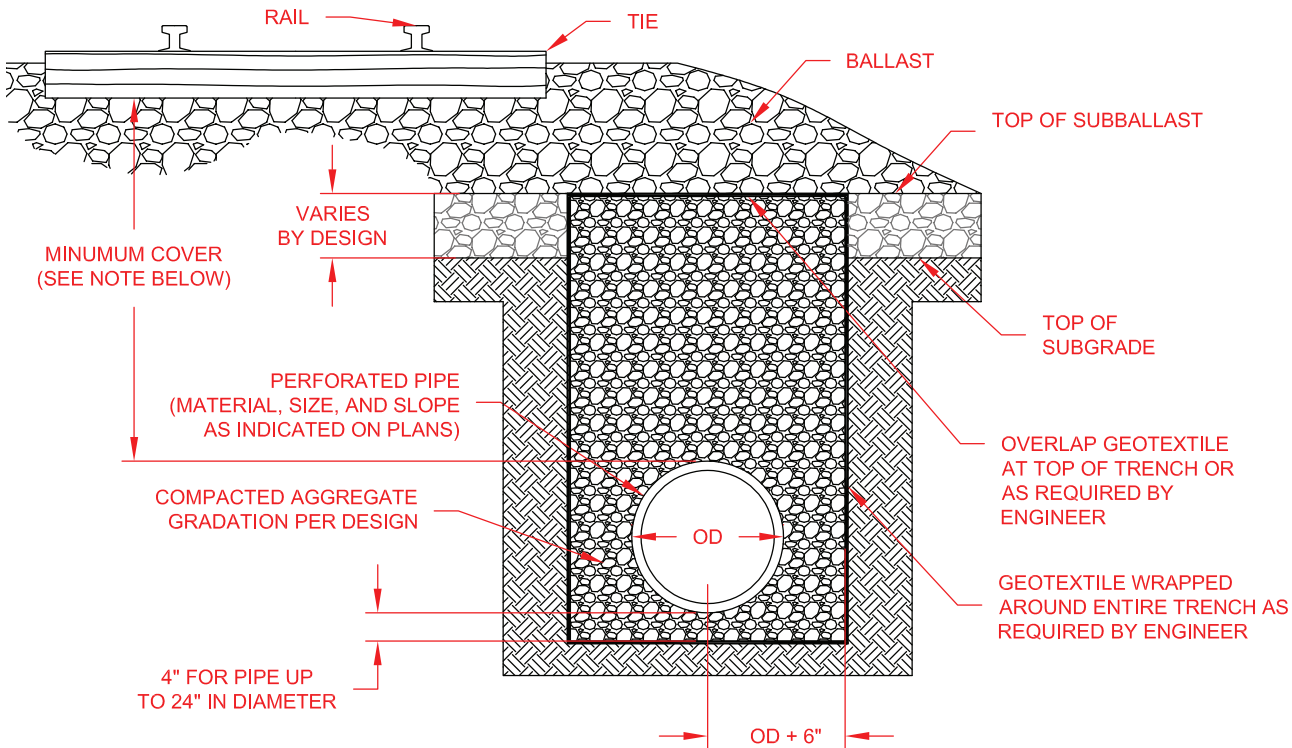

NOTE: COOPER E-80 LOADING HAS A MINIMUM COVER REQUIREMENT OF 24" FROM CROWN OF PIPE TO BOTTOM OF RAILROAD TIE. SEE ADS STANDARDS FOR MINIMUM COVER REQUIREMENTS IN NON-COOPER E-80 LOADING APPLICATIONS, OR IF PIPE DIAMETERS EXCEED 24".

adspipe.com