

Aquabox

Aquabox is a globally proven modular underground system designed for sustainable stormwater management. Systems have been installed in 25 countries.

The Aquabox system is designed primarily to be used under parking lots, thus maximizing land usage for private (commercial) and public applications. The Aquabox can also be used in conjunction with Green Infrastructure, thus enhancing the performance and extending the service life of these practices.

Why Aquabox

- Structurally superior compared to the majority of crates on the market today
- Fast and easy to install, allows for a high load resistance, and has a 96% void
- Manufactured from recycled polypropylene with fiberglass additive
- Adaptable components enable highly customized layouts, creating the perfect fit for complex sites



Features

- Fast and easy installation
- High load resistance
- Open and flexible system that can be used for both detention, retention (infiltration) and water harvesting applications
- 96% void
- 750 x 750 x 800 mm (29.5" x 29.5" x 31.5") modular modules that are easy to manage
- 0.43 m³ (15.24 ft³) per Aquabox module

Benefits

- Internal configuration makes the system easily accessible for inspection, maintenance & cleaning
- Modules are stackable, allowing 450 m³ (15,892 ft³) of installed volume to be transported in a single truckload
- Designed for the passage of heavy vehicles, load class HS20.
- Can be installed adjacent to StormTech Isolator Row PLUS chambers for enhanced inspection & maintenance.
- Compatible with Aquabox Half Modules to form 1.5-layer and 2.5-layer systems.

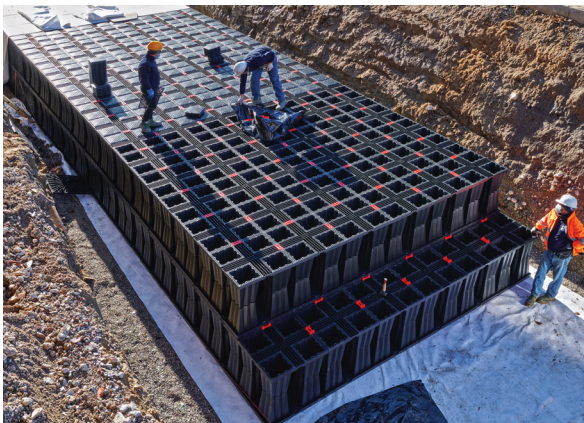

Aquabox Specifications

Dimensions	750 x 750 x 800 mm (29.5" x 29.5" x 31.5")
Weight	20.4 kg (45 lbs)
Material	Recycled polypropylene with glass additive
Net volume	0.43 m ³ (15.24 ft ³)
Void	96%
Pallet Size	9800 x 1520 x 2580 mm (385.8" x 60.0" x 101.6")
Number of pieces per pallet	80

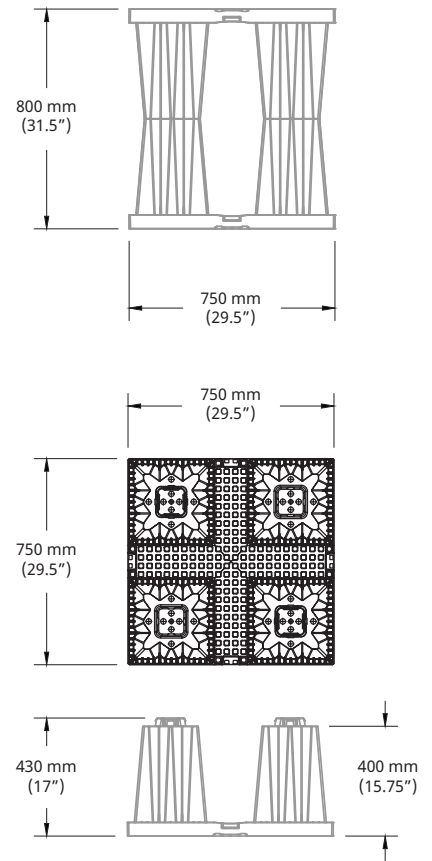

Cross Section

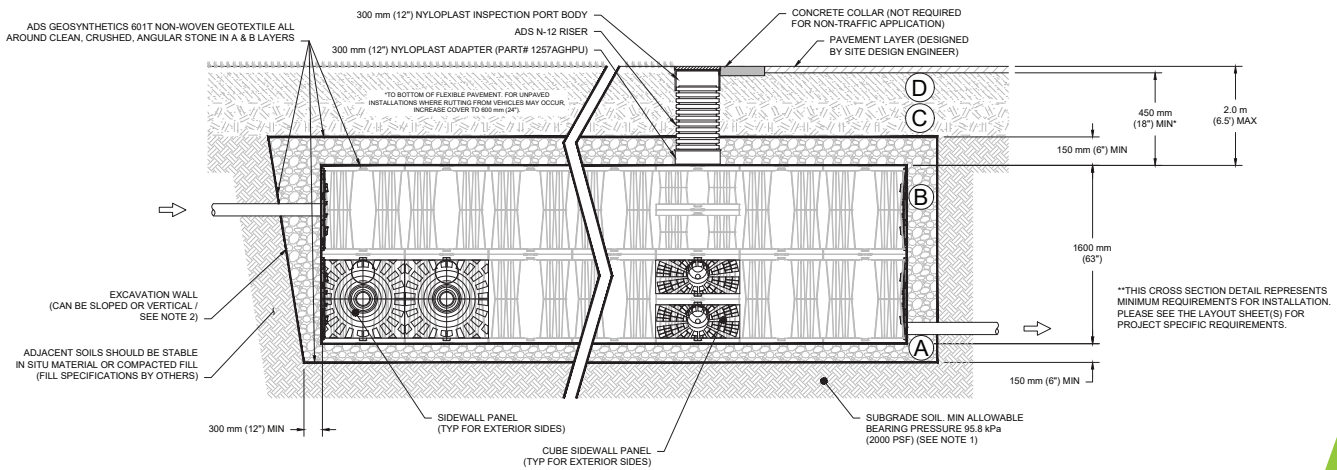

Visit adspipe.ca/water-management-solutions/retention/aquabox for more information.



adspipe.ca