

Design and Installation Manual for **Advanced Enviro-Septic** **New York**



This manual aims to outline the essential design and installation guidelines for the Advanced Enviro-Septic System in New York. All local ordinances, requirements, and procedures must be followed. Each revised version of this manual supersedes the previous version. **For more detailed design information, please contact Infiltrator Water Technologies at (800) 221-4436.**

Table of Contents

Introduction.....	2
Sizing	6
System Design - Trenches.....	8
System Design - Beds.....	11
System Configurations.....	15
Installation Instructions.....	21
Operation And Maintenance	23
Warranty	25



INTRODUCTION

The Advanced Enviro-Septic® (AES) Wastewater Treatment System utilizes a unique combination of components that work together to treat effluent and prevent suspended solids from sealing the underlying soil. Comprised of a patented corrugated, perforated plastic pipe, the large-diameter pipe retains suspended solids while the Bio-Accelerator® fabric, coarse fibers, and geo-textile fabric provide multiple bacterial surfaces to treat effluent prior to its contact with the receiving soils.

The Bio-Accelerator fabric that is located at the bottom of the pipe acts as a subtle clogging layer to force the effluent to travel the full length of the pipe prior to dispersal, therefore providing linear loading. This, just like pressure distribution, helps transport the effluent throughout the basal area to take advantage of the entire basal area in slower soils and higher restrictive layers. The AES system is completely passive and yet provides increased aeration and a greater bacterial treatment area than traditional systems. The continual cycling of effluent (the rising and falling of liquid inside the pipe) enhances bacterial growth. The result is a system that is more efficient, lasts longer, and reintroduces highly treated water directly back into the water cycle.

Testing in accordance with NSF/ANSI Standard 40 has determined that the AES System is capable of treating domestic strength wastewater to Class 1 (secondary) treatment levels.

AES Pipe

- Nominal exterior diameter of 12 inches
- Holding capacity of 5.8 gallons per foot
- 10-foot length of AES pipe is flexible enough to bend up to 90° and can be cut to any length
- Made with recycled material
- Made in USA

Offset Adapter

A 12-inch plastic fitting with a single inlet hole oriented the 12 o'clock position and designed to accept a 4-inch sewer line, raised connection or vent pipe.

Double Offset Adapter

A 12-inch plastic fitting with two 4-inch holes designed to accept a 4-inch inlet pipe, raised connection, optional vent or vent manifold, and/or bottom drain, depending upon the requirements of the design configuration.

Coupling

A coupling is a plastic fitting used to create a connection between two pieces of pipe. Note that the couplings are wide enough to cover 1 or 2 pipe corrugations on each of the two pipe ends being joined (minimum of 1 corrugation coverage; 2 corrugations coverage preferred). The couplings feature a snap-lock feature that requires no tools.

(ESC) When assembling pipes into rows, note that the geo-textile fabric does not go under couplings. When using original ESC coupling, pull the fabric back, install coupling, and then pull the fabric over the end of the coupling. A minimum 1-inch overlap is required between the end of the coupling and end of the fabric on each side of the connection. Also note, during installation in cold weather, couplings are easier to work with if stored in a heated location (such as a truck cab) before use.

(ESC-2) When installing a system using Coupling ESC-2, there is no need to pull the fabric back, simply butt the two segments of pipe together and wrap the coupling over the pipe and fabric verify the teeth of the coupling are engaging with the inner corrugations of the pipe and engage the clasp.

System Sand

ASTM C-33 (concrete sand) or NY DOT C-33 natural or manufactured sand, with not more than 3% passing the #200 sieve (verified by washing the sample per the requirements of ASTM C-117 as noted in the ASTM C-33 specification) may be used as to system sand.



Sand Fill

Sand fill may be used to raise the elevation of the system in order to meet the required separation distance from the SHWT or restrictive feature or in side-slope tapers. This sand shall be clean, bank run sand, free of topsoil, organic matter or debris and containing no stones larger than 6 inches. No more than 15% of this sand shall pass through a #100 sieve and no more than 5% shall pass through a #200 sieve. System sand may be used in place of sand fill.

Information Specific to Use of the Infiltrator AES System in New York

This Manual addresses each application listed below individually. If design, installation, operation, or maintenance specifications are not specifically addressed in this manual, relevant requirements in the Standards and any local requirements shall be applicable.

Even distribution can be achieved either by the incorporated Bio-Accelerator fabric or through the inclusion of low-pressure pipe installed in the AES conduit. The Bio-Accelerator provides surface area for the formation of a bio-mat layer that promotes even distribution throughout the system without the use of a pressure distribution pipe system. In both new and repair or replacement situations, AES systems may be designed with or without the use of pressure distribution in the following applications:

Trenches

- A gravelless geotextile sand filter – Appendix 75-A.8(c)(3)(iii)
- A gravelless media-wrapped corrugated pipe sand-lined systems – Appendix 75-A.8(c)(3)(ii);
- A shallow absorption trench system – Appendix 75-A.8(e);
- Cut and fill system – Appendix 75-A.8(f); and
- A raised system – Appendix 75-A.9(b).

Beds

- An absorption bed system – Appendix 75-A.8(g); and
- A mound system – Appendix 75-A.9(c).

Intermediate-sized Systems and Systems Outside the Limits of Appendix 75-A

The AES system can be specified on systems outside the limits of the Rules with use of a specific waiver. Designers may use this manual as a reference guide for the basis of design. Systems with daily flows greater than 1,000 gallons per day (Intermediate-sized Systems) are regulated by the New York State Department of Environmental Conservation (NYSDEC) and may be required to be designed by a licensed engineer. The loading rates and sizing for this manual are based on typical residential strength wastewater. Therefore, it is recommended that the engineer modify the design accordingly to address higher strength waste if necessary. Contact Infiltrator Water Technologies (Infiltrator) Technical Support at 1-800-221-4436 for recommendations.

Environmental Standards

All AES systems shall be designed and installed in compliance with the procedures and specifications detailed in this Manual. In the event of contradictions between this Manual and Appendix 75-A, Infiltrator Water Technologies (Infiltrator) should be contacted for technical assistance at 1-800-221-4436.

The configurations present in this document are common designs and are provided for illustrative purposes. They are not intended to restrict the use of other configurations, which may be utilized provided the design conforms to 10 NYCRR, Department of Health, Chapter II, Part 75, Appendix 75-A Wastewater Treatment Standards—Individual Household Systems and other state and local regulations.

Training and Certification Requirements

Designers and installers are required to attend an in-person or online training/certification course on AES presented by Infiltrator or its authorized representative. Infiltrator recommends that professionals involved in the review of AES system designs and inspection of installed systems also become trained and certified.

Visit <https://www.infiltratorwater.com/online-training-programs/new-york/> for your state offerings.

Daily Design Flow

Daily design flow (DDF) is calculated in accordance with the Standards. Daily design flow for residential systems is calculated by multiplying the number of bedrooms by 110, 130, or 150 gpd depending on the water usage and number of the fixtures. Residential systems are limited to a minimum of 300 gpd and a maximum of 1,000 gpd daily design flow.

Effluent (Wastewater) Strength

The minimum total AES pipe required is based on use with residential (domestic) strength effluent that has received primary treatment in a septic tank. For high strength waste systems, visit our website at www.infiltratorwater.com/ for a copy of the High Strength Waste Recommendations document.

Separation Distances and Setbacks

The minimum required separation distance to the highest restrictive feature in the soil profile is 24 inches from seasonal high-water table (SHWT) and 48 inches from ledge, bedrock or impermeable soils (perc rates greater than 120 mpi). Vertical separation distances are measured from 6 inches below the AES pipe. Minimum horizontal separation distances (also called “setbacks”) must comply with state and local requirements. For systems

installed below grade, setbacks are measured from the outer perimeter of the system sand. For systems that require side-slope tapering (mound systems), setbacks are measured from the toe-of-slope.

Water Purification Systems

Infiltrator does not recommend discharging water softener backwash into the AES system. This “backwash” does not require treatment and the additional flow may overload the system. Regulatory requirements may allow for alternative means of disposal. If there is no alternative means of disposing of this backwash other than into an AES system, determine system backwash flow and increase the system DDF accordingly.

System Soil Cover Material

A minimum of 6 inches of suitable earth cover (topsoil or loam) with a texture similar to the soil at the site and capable of sustaining plant growth, must be placed above the installed system. The addition of filtration fabric on top of the AES system is not required before placing cover material. No barrier materials (hay, straw, tarps, etc.) are to be placed between the system sand and cover material.

Acceptable Distribution Methods:

Serial Distribution

All rows are connected in series at the ends with raised connections, using offset adapters. Systems designed to receive 750 gpd or less may be designed in one serial section.

Single section serial system

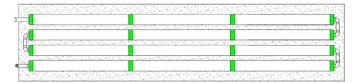

Systems receiving more than 750 gpd require multiple serial sections containing equal sections of AES pipe fed from a d-box.

Multiple section serial system

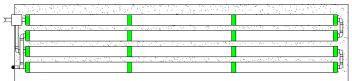

Serial sections must have the same linear feet of AES pipe. Minimum linear feet of AES pipe per section is determined by dividing the total linear feet required in the system by the number of sections required. A section may exceed the minimum linear length and rows within a section may vary in length to accommodate site constraints.

Parallel Distribution

Systems may be designed using a distribution box to feed each individual row of AES conduit. This distribution method may be used for any daily design flow and conduit rows must be of equal length. There is no minimum separation distance requirement from a D-box to the AES pipe

Pressure Distribution

The requirement for the use of pressure distribution may be met in two ways:

1. By relying on the Bio-Accelerator to provide even distribution throughout the system.
2. By including low pressure piping within the AES conduit.

INTRODUCTION

Two-Inch Rule

The outlet of a septic tank or D-box shall be set at least 2 inches above the highest inlet of the AES row, with the connecting pipe slope not less than 1% (approximately 1/8 inch per foot). Illustration of 2-inch rule:

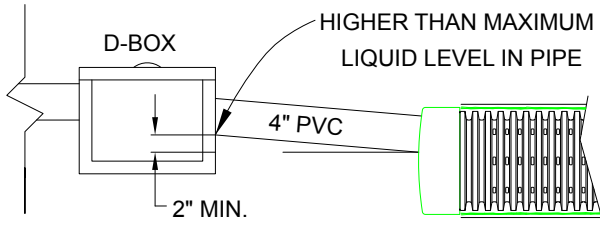

Filters

If used, effluent filters shall be maintained following the manufacturer's instructions regarding required inspections, cleaning, and maintenance.

AES in Trenches

AES pipe may be installed in trench configurations on level or sloping terrain and may utilize serial or parallel distribution. Trench systems incorporate one or more rows of AES pipe per trench. Trench configurations may be used in soils with perc rates up to 60 mpi. Maximum length of trenches is 60 feet. Longer lengths may be allowed with the use of a specific waiver, in accordance with the Regulations. Consult the Regulations for acceptable trench width and/or required trench separation.

NOTE: Infiltrator criteria allows trench lengths up to a maximum of 101 feet (100 feet pipe row length maximum).

AES in Beds

AES may be designed and installed as a bed using the soil application rates from the sizing tables provided in this manual. Bed bottoms may be sloped with the existing terrain to minimize impact to a site. Multiple beds may be designed if site conditions do not allow for a single bed. A recommended design procedure, which shows equal spacing, is provided in this manual. However, modified spacing is permitted, provided minimum and maximum criteria for bed length and width are met.

In both new and repair or replacement situations, AES systems may be designed with or without the use of pressure distribution.

AES System Definitions

In this document minimum system treatment cell area refers to the surface onto which the AES rows are placed and the 6 inches of system sand between and 6 below and on the perimeter of the AES pipes. Maintaining this minimum system sand footprint area is required to ensure adequate treatment. Minimum System Sand Bed Area (SSBA) refers to the minimum basal area required based upon the soil loading rate for a given DDF. Maintaining this SSBA is required to ensure long-term hydraulic performance.

System Sand Extensions (SSE) in Bed Designs

AES will treat the wastewater in a properly designed system treatment cell, based on the design flow to the system, without regard for the soils the system is placed in or upon. To ensure long-term hydraulic performance, it may be necessary to increase the system sand bed footprint beyond what

is needed to accommodate the flow-based design treatment area. This additional area is made up of system sand extension(s) (SSEs). SSEs are a minimum of 6 inches deep. In systems sloping more than 5%, a minimum 2.5-foot-wide SSE is required.

SSEs are placed entirely on the downslope side of the SSBA for sloping AES systems and equally divided on each side of the SSBA for level AES systems as shown in the system layouts section of this manual.

Sloping Sites and Sloping Systems

- The system slope and site slope do not have to be the same.
- The site and/or the system may contain more than one slope, provided the maximum allowed slope is not exceeded. This configuration is limited to use in soils with perc rates of 1-60 mpi.
- The regulations place restrictions on the level of slope a site may have in order to accommodate an onsite wastewater system. The allowable slope varies based on the system type. Table A below details these restrictions.

Table A: System and Site Slope Limitations

System Type	Maximum Slope on Site Per Regulations
Trench	15%
Alternative System	15%
Mound	12%
Absorption Bed	8%

NOTE: Exceeding these site slope limitations requires a specific waiver.

- A specific waiver may be issued to allow for design and installation of systems with slopes that exceeds these restrictions. Infiltrator Water Technologies allows a maximum site slope of 33% and a maximum bed system slope of 25%. Table B provides Infiltrator Water Technologies' maximum site slopes and system slopes based on the soil's perc rate.

Table B: Infiltrator Water Technologies Recommended Maximum System and Site Slopes

Infiltrator Water Technologies Recommended Maximum Slope Based on Soil Perc Rate*		
Perc Rate Minutes Per Inch (mpi)	Site Slope (Maximum %)	System Slope (Maximum %)
1-30	33	25
31-40	25	20
41-50	20	15
51-60	15	10
61-120	5	5

* May require a specific waiver.

Fill Extension Requirements

All systems with any portion of the system sand bed above original grade require 6-inch fill extensions on each side beyond the outside edge of all AES pipes and then tapering to meet existing grade at a maximum slope of 3:1. There must be a minimum of 12 inches of cover material over the ends of all system sand extensions (if present).

Pump Systems

Pumped systems supply effluent to the system using a pump and D-box when site conditions do not allow for a gravity system. Dosing siphons are also an acceptable means of delivering effluent to the system. The use of pressure distribution with the AES system is not required but may be used.

- Pump dosing should be designed for a minimum of six cycles per day; 6-8 cycles per day are recommended.
- Pump volume per dose shall be no greater than one gallon per total linear foot of AES pipe but may be used..
- If possible, the dosing cycle should provide one hour of drying time between doses.
- Pump systems must have a high-water alarm float or sensor installed inside the pump chamber. Follow state, local, and national code requirements.
- All pumped to gravity systems require a D-box with baffles, a velocity reducing tee or other means to be used for velocity reduction.
- Pumped systems with one serial section are limited to a maximum dose rate of 40 GPM.

Row Requirements

- All beds shall have at least two rows. Trenches may contain either one or two rows per trench.
- Maximum row length for any AES system is 100 ft of pipe.
- AES rows longer than 60 ft require a specific waiver.
- Recommended minimum row length is 30 feet of pipe.
- Minimum center-to-center spacing is 1.5 feet for all bed systems. Spacing may be increased at the discretion of the system designer.
- Sewn seam must be oriented in the 12 o'clock position. This correctly orients the Bio-Accelerator® fabric in the 6 o'clock position.
- For level beds, the rows are centered in the middle of the basal area.
- For sloping beds, system sand extensions should be placed entirely on the downslope side of the bed.
- Each row must be placed along the contour of the site and laid level to within +/- 1/2 inch (total of 1 inch) of the specified elevation. It is a best practice to include row elevations for each AES row in the system on the construction drawing(s).
- It is best to design row lengths in 10' increments, however AES pipe can be cut to any length.

H-20 Loading

AES may be designed and installed in H-20 load bearing applications. If AES

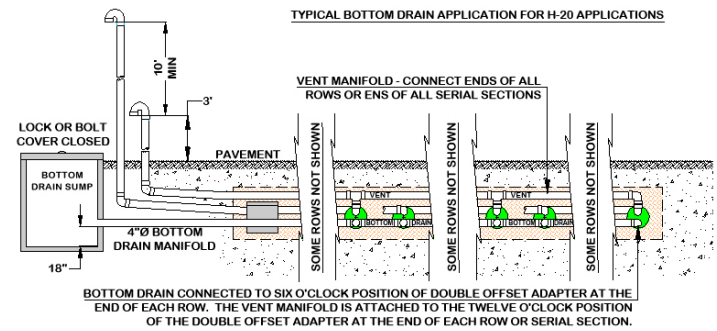

is installed below an area that will be subjected to vehicular traffic, it must be designed and constructed as depicted in order to protect the system from compaction and/or damage.

NOTE: that a thin layer of stabilization fabric is added between the 6 inches of system sand cover and the cover material. All H-20 systems require venting.

Bottom Drain

A bottom drain consists of a line connected to the hole in the 6 o'clock position of a double offset adapter at the end of each row which drains to a sump and is utilized to lower the water level in a saturated system to facilitate AES rejuvenation. There must be 18 inches from the bottom of the sump to the bottom of the drain. The sump should be brought above the final grade and have a locking or mechanically fastened cover.

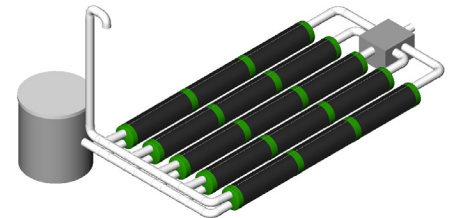

Venting

Venting is optional at the discretion of the designer when the system design includes 18 inches of cover or less (measured from the top of the AES pipe). If venting is included in the design, it can be accomplished using differential venting (the use of high and low vents in a system). Vent openings should be located to ensure the unobstructed flow of air through the entire system. When using the house roof vent as the high vent, the roof vent must be a minimum of 3 inches in diameter. A low vent is installed through an offset adapter at the end of each section or bed and shall be a minimum of 4 inches in diameter. A vent manifold may be used to connect the ends of multiple sections or rows. The low vent inlet shall be a minimum of 1 foot above final grade or anticipated snow level. Vents extending more than 3 feet above grade should be anchored. More detailed information on venting an AES system is available on the Infiltrator website at www.infiltratorwater.com.

-sizing

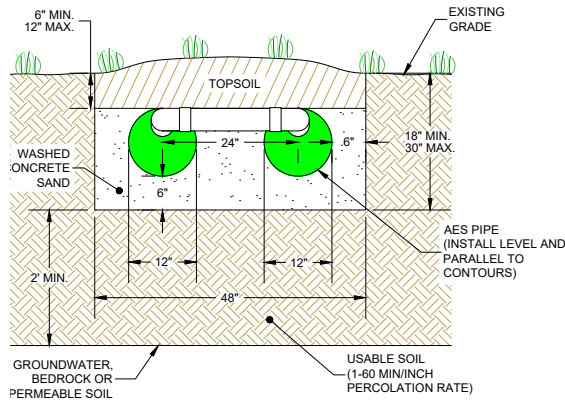

Table C: Trench Configuration—Gravelless Geotextile Sand Filter (GGSF Trench) - Minimum Trench Length

Perc Rate (MPI)	Daily Flow Rate -- Gallons Per Day (gpd)																
	2 BR	3 Bedrooms			4 Bedrooms			5 Bedrooms			6 Bedrooms			7 Bedrooms		8 BR	9 BR
	300	330	390	450	440	520	600	550	650	750	660	780	900	770	910	880	900
1-5	42	46	54	63	61	72	83	76	90	104	92	108	125	107	126	122	138
6-7	50	55	65	75	73	87	100	92	108	125	110	130	150	128	152	147	165
8-10	56	61	72	83	81	96	111	102	120	139	122	144	167	143	169	163	183
11-15	63	69	81	94	92	108	125	115	135	156	138	163	188	160	190	183	206
16-20	71	79	93	107	105	124	143	131	155	179	157	186	217	183	217	210	236
21-30	83	92	108	125	122	144	167	153	181	208	183	217	250	214	253	244	275
31-45	100	110	130	150	147	173	200	183	217	250	220	260	300	257	303	293	330
46-60	111	122	144	167	163	193	222	204	241	278	244	289	333	285	337	326	367

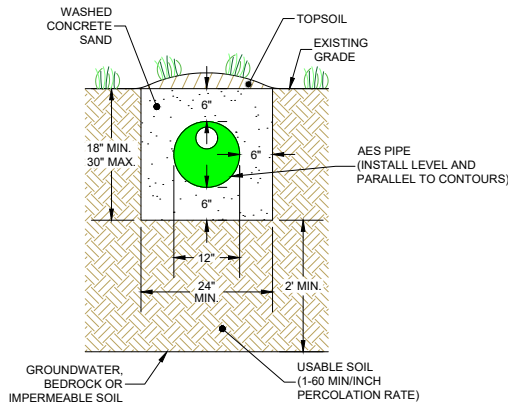

Table D: Trench Configurations—2-Foot-Wide Trench (25% reduction) - Minimum Trench Length

Perc Rate (MPI)	Daily Flow Rate -- Gallons Per Day (gpd)												
	2 BR	3 Bedrooms			4 Bedrooms			5 Bedrooms			6 Bedrooms		
	300	330	390	450	440	520	600	550	650	750	660	780	900
1-5	94	103	122	141	138	163	188	172	203	234	206	244	281
6-7	113	124	146	169	165	195	225	206	244	281	248	293	338
8-10	125	138	163	188	183	217	250	229	271	313	275	325	375
11-15	141	155	183	211	206	244	281	258	305	352	309	366	422
16-20	161	177	209	241	236	279	321	295	348	402	354	418	482
21-30	188	206	244	281	275	325	375	344	406	469	413	488	563
31-45	225	248	293	338	330	390	450	413	488	563	495	585	675
46-60	250	275	325	375	367	433	500	458	542	625	550	650	750
Minimum Total System Sand Trench Length in Feet (Based Upon 2-Foot-Wide Trench)													

Table E—AES Pipe Requirements for Bed Designs

System Type	Minimum AES Pipe Loading Rate
Residential System	70 feet per Bedroom
Intermediate-sized System	2.14 gpd/foot

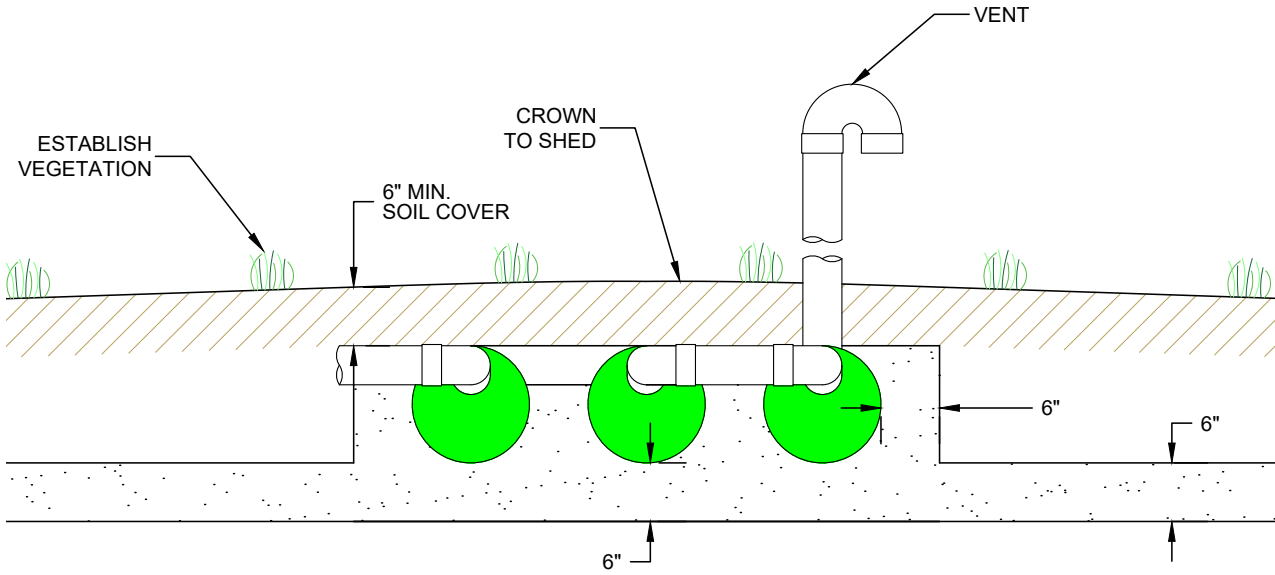

Table F - AES Bed Application Rates

Perc Rate (MPI)	Residential Systems		Intermediate Systems
	New Construction	Repair/Remediation	NYDEC Recommended Sewage Application Rate (gpd/square foot)
	Application Rate (gpd/square foot)	Application Rate (gpd/square foot)	
1-5	0.95	1.47	1.20
6-7	0.80	1.33	1.00
8-10	0.70	1.17	0.90
11-15	0.60	1.00	0.80
16-20	0.55	0.92	0.70
21-30	0.45	0.75	0.60
31-45	-	0.67	0.50
46-60	-	0.58	0.45
61-80	-	0.50	0.20
81-100	-	0.42	
101-120	-	0.33	

SYSTEM DESIGN — GGSF Trench

GGSF Trench Design Procedure

Step 1: Determine Total Trench Length Required

Use Table C to determine the minimum total trench length required based on the daily design flow and the site's percolation rate.

Step 2: Choose a Trench Length

Select a system sand trench length based on site constraints (61 feet maximum without waiver).

Step 3: Determine Minimum Number of Trenches

Calculate minimum number of trenches needed. Divide the total trench length from Step 1 by the selected trench length for the site from Step 2. Round up to the nearest whole number or adjust trench length selected in Step 2.

Step 4: Determine Amount of AES Pipe Required

Calculate AES pipe needed to fill trenches: Subtract 1 foot from the total trench length used to allow for 6 inches of perimeter sand on each end of the trench, then multiply the answer by the number of trenches from Step 3. Multiply the answer by 2 (AES requires 2 rows of pipe per trench).

GGSF Trench Design Example

Residential system, three bedrooms (330 gpd), level site, 12 mpi percolation rate, system design using serial distribution.

Step 1: Determine Total Trench Length Required

Total trench length minimum from Table C = 69 feet.

Step 2: Choose a Trench Length

Use 36 feet trench length due to site constraint.

Step 3: Determine Minimum Number of Trenches

Number of trenches required = 69 feet ÷ 36 feet = 1.9, round up to 2 trenches.

Step 4: Determine Amount of AES Pipe Required

AES pipe required to provide two rows in each trench = [(36 feet - 1 foot x 2)] x 2 = 140 feet.

Illustration of design example:

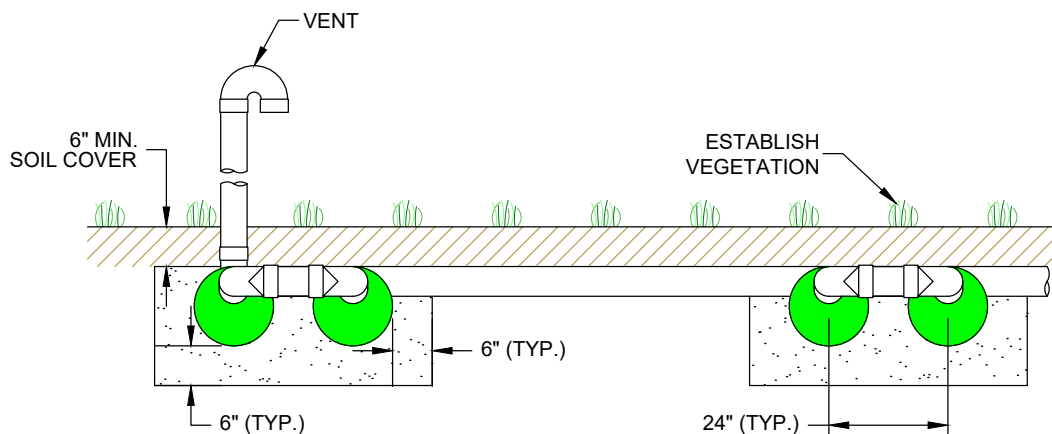

SYSTEM DESIGN — 2-Foot-Wide Trench

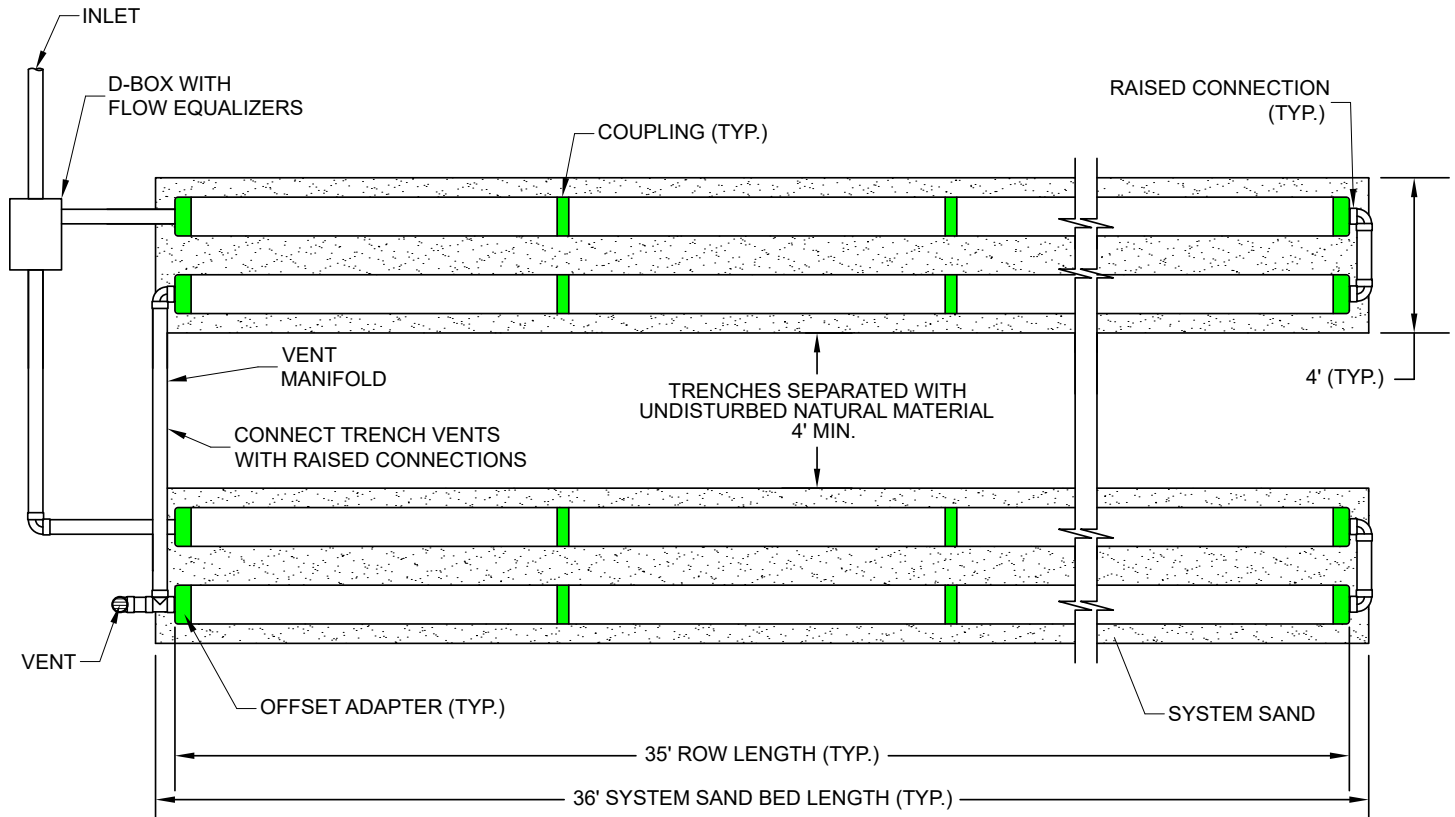

2-Foot-Wide Trench Design Procedure

Step 1: Determine Total Trench Length Required

Use Table D to determine the minimum total trench length required based on the daily design flow and the site's percolation rate.

Step 2: Choose a Trench Length

Select a system sand trench length based on site constraints (61 feet maximum without waiver).

Step 3: Determine Minimum Number of Trenches

Calculate minimum number of trenches needed. The total number of trenches is equal to the total trench length from Step 1 divided by the selected trench length in Step 2, rounded to the nearest whole number.

Step 4: Determine Amount of AES Pipe Required

Calculate AES pipe needed to fill trenches: (Total trench length from Step 1 minus 1 foot multiplied by the number of trenches from Step 3).

2-Foot-Wide Trench Design Example

Residential system, four bedrooms (440 gpd), level site, 7 mpi percolation rate, use D-box distribution.

Step 1: Determine Total Trench Length Required

Total trench length minimum from Table D = 165 feet.

Step 2: Choose a Trench Length

Use 56 feet trench length.

SYSTEM DESIGN — 2-Foot-Wide Trench

Step 3: Determine Minimum Number of Trenches

Number of trenches required = 165 feet ÷ 56 feet = 2.95, round up to 3 trenches.

Step 4 Determine Amount of AES Pipe Required

AES pipe required to provide two rows in each trench = (56 feet - 1 foot) x 3 = 165 feet.

Illustration of design example:

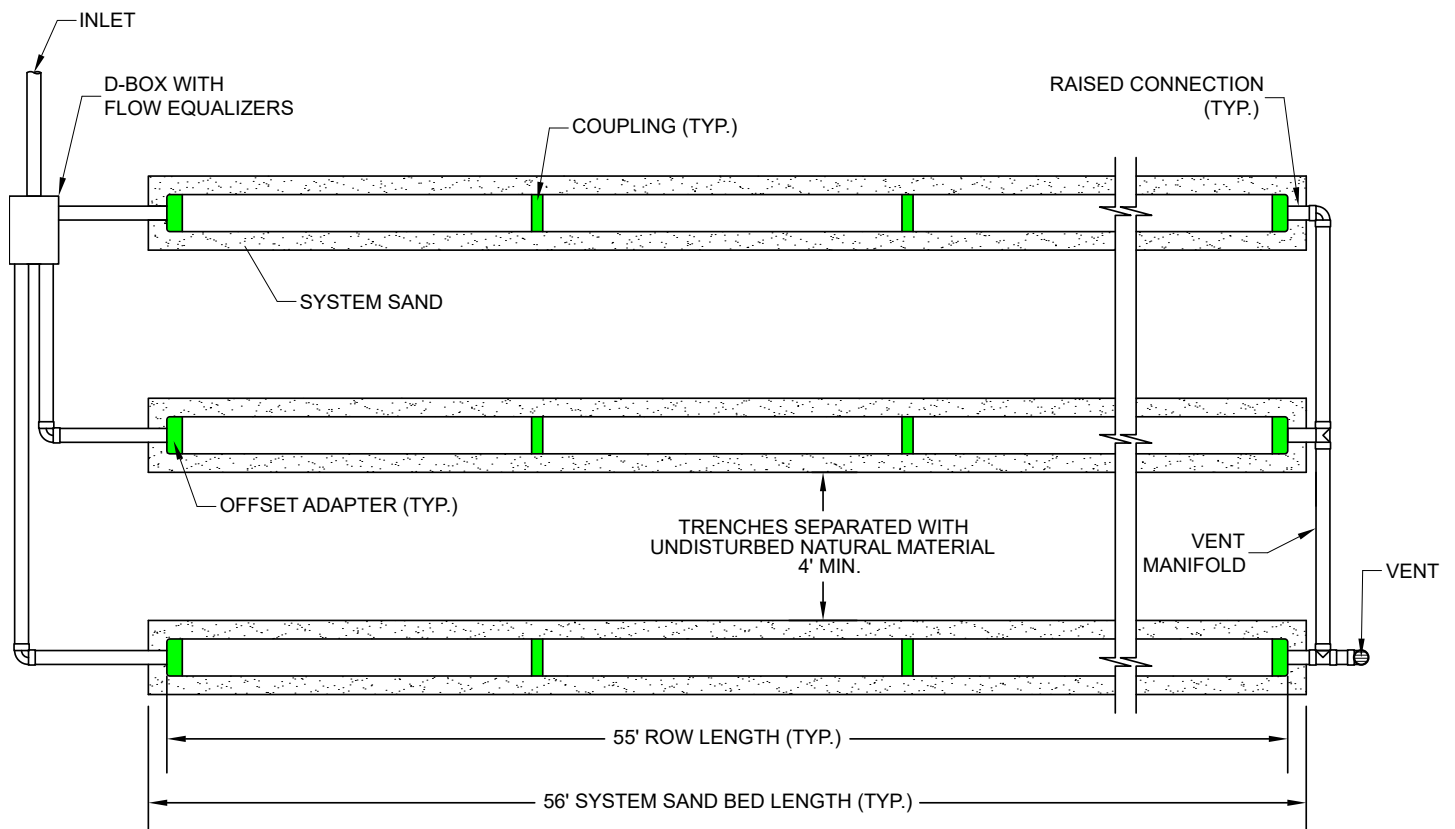
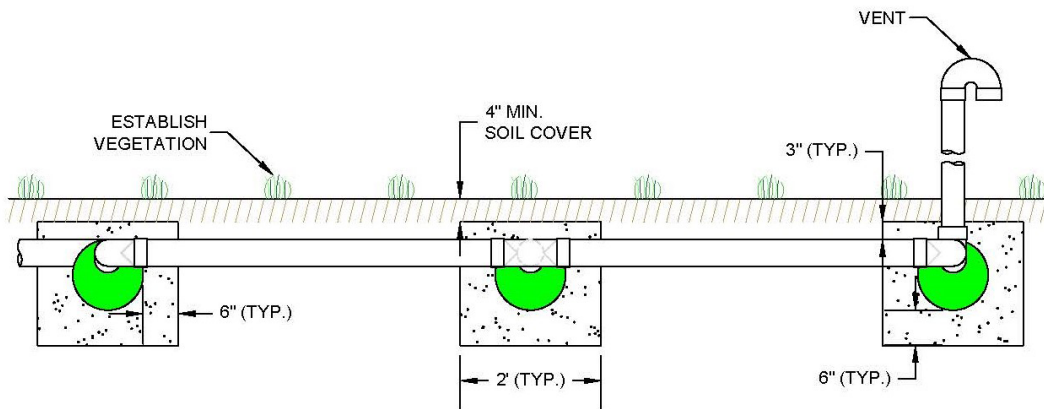

Bed configurations place AES rows parallel to one another in a single field. Bed configurations must adhere to the following criteria:

- Can be used for new construction residential systems in soils with perc rates up to 30 mpi, as required by the Regulations.
- Remediation and replacement bed systems with perc rates >60 mpi are limited to 4 bedrooms per bed, as required by the Regulations.
- A minimum 2:1 length to width ratio is recommended for bed configurations when site conditions allow.
- Minimum separation distance between beds is 20 feet, measured from the edge of system sand.
- 61 feet maximum system sand bed length (without a specific waiver).
- Must adhere to row requirements outlined on page 5.
- Maximum site and system slope 8% for bed configurations (without a specific waiver).

NOTE: Even distribution can be achieved either by the incorporated Bio-accelerator fabric or through the inclusion of low-pressure pipe installed in the AES conduit. The Bio-Accelerator provides surface area for the formation of a bio-mat layer that promotes even distribution throughout the system without the use of a pressure distribution system. In both new and repair or replacement situations, AES systems may be designed with or without the use of pressure distribution in bed applications.

AES Bed Design Procedure

Step 1: Calculate the Minimum Amount of AES Pipe Needed from Table E

- a) Residential Systems: Number of bedrooms multiplied by 70 feet/bedroom.
- b) Commercial (Non-Residential Systems): Daily design flow divided by 2.14 gpd/foot.

NOTE: Visit our website at www.infiltratorwater.com/ for a copy of the High Strength Waste Recommendations document.

Step 2: Determine System Daily Design Flow

Calculate daily design flow based on 110, 130, or 150 gpd per bedroom (depending on fixtures utilized). (See Regulations to determine the system's daily design flow).

Step 3: Calculate the Minimum System Sand Bed Area (SSBA)

From Table F: Using the soil's percolation rate and daily design flow, find the appropriate application rate for the system (new construction vs. repair). Divide the daily design flow from Step 2 by the application rate selected.

Step 4: Calculate Number of Serial Sections Needed

Calculate the minimum number of serial sections required (does not apply to parallel distribution): Divide the daily design flow by 750 gpd (if fractional, round up to nearest whole number).

Step 5: Determine Row Length and Quantity Needed

Select a row length suitable for the site and calculate the number of rows needed (if fractional, round up to nearest whole number). Maximum row length is 60 feet (61 feet for the system sand bed length) without a specific waiver. The number of rows must be evenly divisible by the number of serial sections required (add rows as necessary or use a D-box parallel distribution layout).

Step 6: Determine Pipe Layout Width (PLW)

Calculate the PLW using a 1.5 feet minimum center-to-center row spacing (larger spacing allowed). PLW is equal to [(the number of rows minus 1) multiplied by (row center to center spacing)] plus 1 foot.

Step 7: Determine Minimum System Sand Bed Width (SSBW)

Calculate the minimum SSBW by dividing the SSBA from Step #3 by the selected row length from Step #5 then add 1 foot (allows 6 inches of sand beyond the end of the rows).

SYSTEM DESIGN — Bed Systems

Step 8: Verify Final Bed Width Requirements

- a) Beds sloping 5% or less: If the minimum SSBW from Step #7 is less than the PLW from Step #6 + 1 foot, use (PLW + 1 foot) as the new minimum SSBW. If the minimum SSBW calculated in Step #7 is greater than the PLW from Step #6 + 1 foot, use the SSBW calculation from Step #7.
- b) Beds sloping greater than 5%: If the minimum SSBW from Step #7 is less than the PLW from Step #6 + 3.5 feet, use (PLW + 3.5 feet) as the new minimum SSBW. If the minimum SSBW calculated in Step #7 is greater than the PLW from Step #6 + 3.5 feet, use the SSBW calculation from Step #6.

Step 9: Calculate System Sand Extensions (SSEs)

- a) Level Beds: SSEs are placed on each side of AES pipes = $[SSBW - (PLW + 1)] \div 2$. There will be no SSE's if the SSBW = (PLW + 1 foot).
- b) Sloping Beds: SSE placed entirely on the down slope side of the bed = $SSBW - (PLW + 1)$ and must be at least 2.5 feet for beds sloping over 5% (3 feet from the edge of the AES pipe).

AES Bed Design Example #1

New Residential Construction, four bedrooms (440 gpd), level site, percolation rate of 16 mpi, serial distribution layout.

NOTE: Even distribution can be achieved either by the incorporated Bio-accelerator fabric or through the inclusion of low-pressure pipe installed in the AES conduit. The Bio-Accelerator provides surface area for the formation of a bio-mat layer that promotes even distribution throughout the system without the use of a pressure distribution system. In both new and repair or replacement situations, AES systems may be designed with or without the use of pressure distribution in bed applications

Step 1: Calculate the Minimum Amount of AES Pipe Needed from Table E:

AES pipe required = 4 bedrooms x 70 feet/bedroom = 280 feet.

Step 2: Determine System Daily Design Flow

Daily design flow for this system is being calculated at 110 gpd/bedroom 4 bedrooms at 110 gpd each - 440 gpd. Alternatively, this system could have been calculated at 130 or 150 gpd/bedroom.

Step 3: Calculate the Minimum System Sand Bed Area (SSBA)

Minimum SSBA = daily design flow ÷ application rate from Table F. $440 \text{ gpd} \div 0.55 \text{ gpd/square foot} = 800 \text{ square feet}$.

Step 4: Calculate Number of Serial Sections Needed

Serial sections required = $440 \text{ gpd} \div 750 \text{ gpd/section} = 0.59$ (round up to 1).

Step 5: Determine Row Length and Quantity Needed

Use a row length of 60 feet: $280 \text{ feet} \div 60 \text{ feet} = 4.67$ rows (round up to 5). Alternatively, a row length of 70 feet could have been selected.

Step 6: Determine Pipe Layout Width (PLW)

$[(5 \text{ rows} - 1) \times 1.5 \text{ feet center-to-center spacing}] + 1 \text{ foot} = 7 \text{ feet PLW}$.

Step 7: Determine Minimum System Sand Bed Width (SSBW)

Minimum SSBW: $800 \text{ square feet} \div 61 \text{ feet} = 13.12 \text{ feet minimum}$, round up to 13.25 for ease of construction.

Step 8: Verify Final Bed Width Requirements

- a) 13.25 feet SSBW is more than (7.0 feet PLW + 1 foot); use 13.25 feet as the minimum SSBW.
- b) Bed slopes less than 5%, this step is not required.

Step 9: Calculate System Sand Extensions (SSEs)

- a) SSEs: 13.25 feet from Step #6 is more than 8.0 feet (PLW of 7.0 feet + 1 foot), so $13.25 \text{ feet} - (7.0 \text{ ft PLW} + 1 \text{ foot}) \div 2 = 2.625 \text{ feet}$ extensions are required on each side. (Round up to 2.75 feet for ease of construction.) This will increase the SSBW to 13.5 feet.
- b) Not required, system is not sloping.

Illustration of design example:

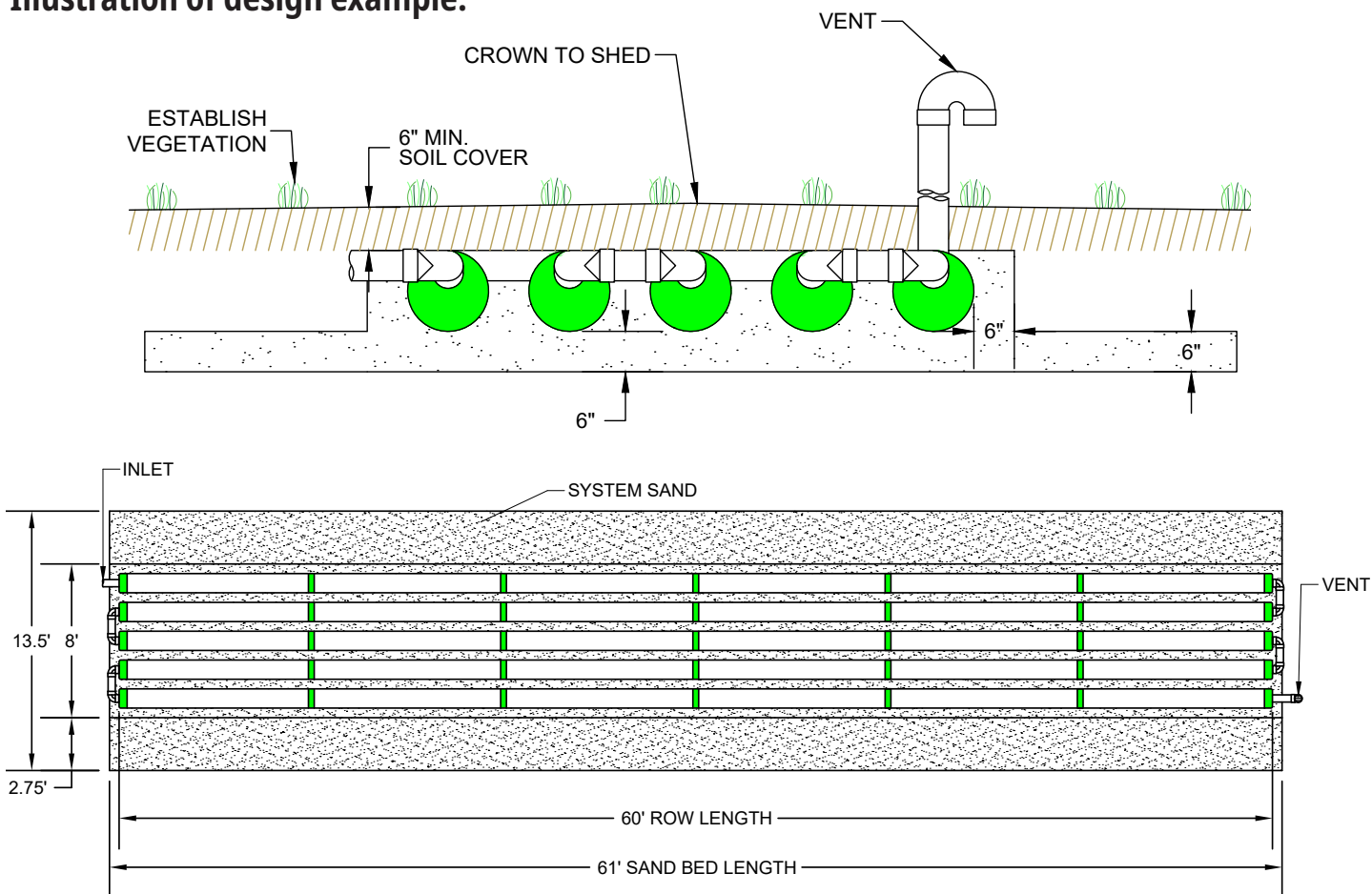

AES Bed Design Example #2

Residential Remediation/Replacement System, three bedrooms (450 gpd), site slope is 8%, percolation rate of 45 mpi, serial distribution layout.

NOTE: Even distribution can be achieved either by the incorporated Bio-accelerator fabric or through the inclusion of low-pressure pipe installed in the AES conduit. The Bio-Accelerator provides surface area for the formation of a bio-mat layer that promotes even distribution throughout the system without the use of a pressure distribution system. In both new and repair or replacement situations, AES systems may be designed with or without the use of pressure distribution in bed applications.

Step 1: Calculate the Minimum Amount of AES Pipe Needed from Table E:

AES pipe required = 3 bedrooms x 70 feet/bedroom, = 210 feet.

Step 2: Determine System Daily Design Flow

Daily design flow for this system is being calculated at 150 gpd/bedroom 3 bedroom at 150 gpd each = 450 gpd. Alternatively, this system could have been calculated at 110 or 130 gpd/bedroom.

Step 3: Calculate the Minimum System Sand Bed Area (SSBA)

Minimum SSBA = daily design flow ÷ application rate from Table F. $450 \text{ gpd} \div 0.67 \text{ gpd/square feet} = 671.64 \text{ square feet}$.

SYSTEM DESIGN — Bed Systems

Step 4: Calculate Number of Serial Sections Needed

Serial sections required = $450 \text{ gpd} \div 750 \text{ gpd/section} = 0.60$ (round up to 1).

Step 5: Determine Row Length and Quantity Needed

Use a row length of 52.5 feet: $210 \text{ feet} \div 52.5 \text{ feet} = 4$ rows.

Step 6: Determine Pipe Layout Width (PLW)

$[(4 \text{ rows} - 1) \times 1.5 \text{ feet center-to-center spacing}] + 1 \text{ foot} = 5.5 \text{ feet PLW}$.

Step 7: Determine Minimum System Sand Bed Width (SSBW)

Minimum SSBW: $671.64 \text{ square feet} \div 53.5 \text{ feet} = 12.56 \text{ feet minimum}$, round up to 12.75 for ease of construction.

Step 8: Verify Final Bed Width Requirements

- Bed slopes greater than 5%, go to b.
- 12.75 feet SSBW is more than (5.5 feet PLW + 3.5 feet); use 12.75 as the minimum SSBW.

Step 9: Calculate System Sand Extensions (SSEs)

- Bed is sloping, go to b.
- $12.75 - (5.5 \text{ feet PLW} + 1) = 6.25 \text{ feet}$. 6.25 feet exceeds the minimum 2.5 feet SSE required for beds sloping over 5%.

Illustration of design example:

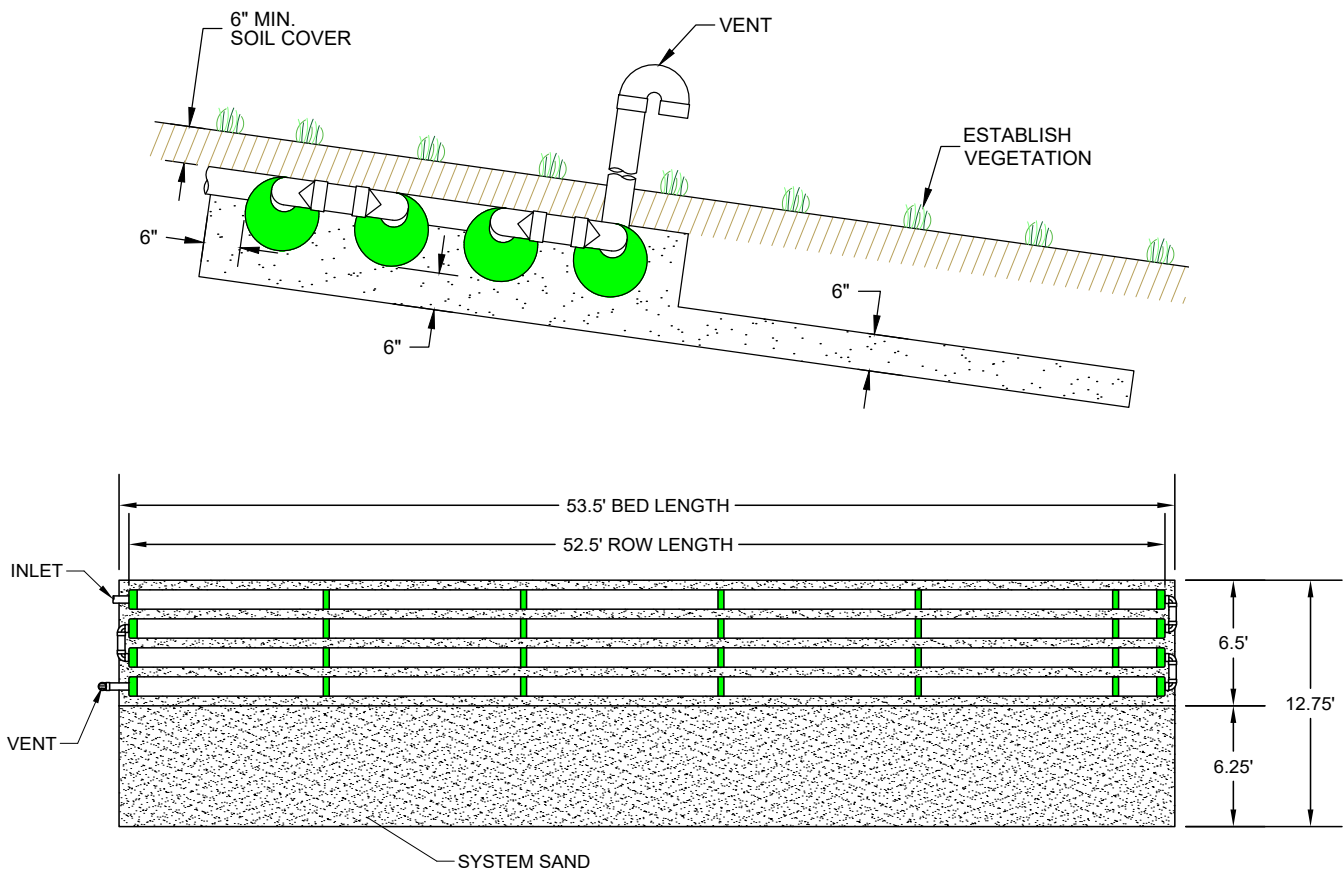

Gravelless Geotextile Sand Filter (GGSF) – Appendix 75-A.8(c)(3)(iii)

AES may be installed in gravelless geotextile sand filter (GGSF) applications for both new and replacement systems. Trench lengths are determined in accordance with Appendix 75-A.8(c)(3)(iii). Trench excavations shall be 48" wide and receive a credit of 6 square feet per linear foot (sf/lf). Manufacturer-recommended and rule-compliance designs include the following:

Cross Section View

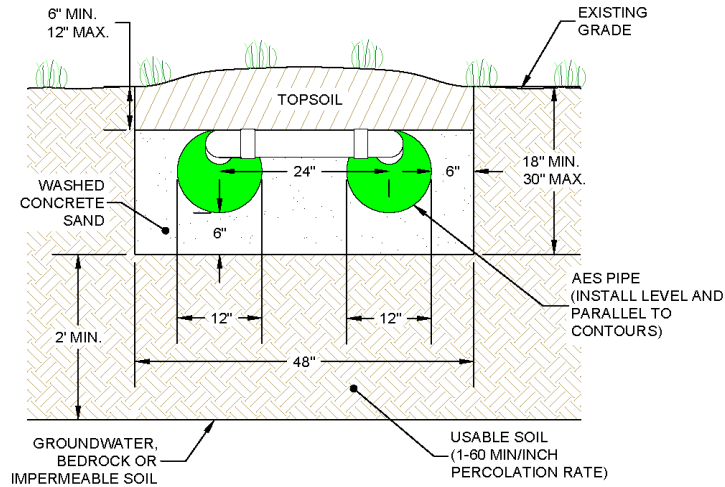

Plan View

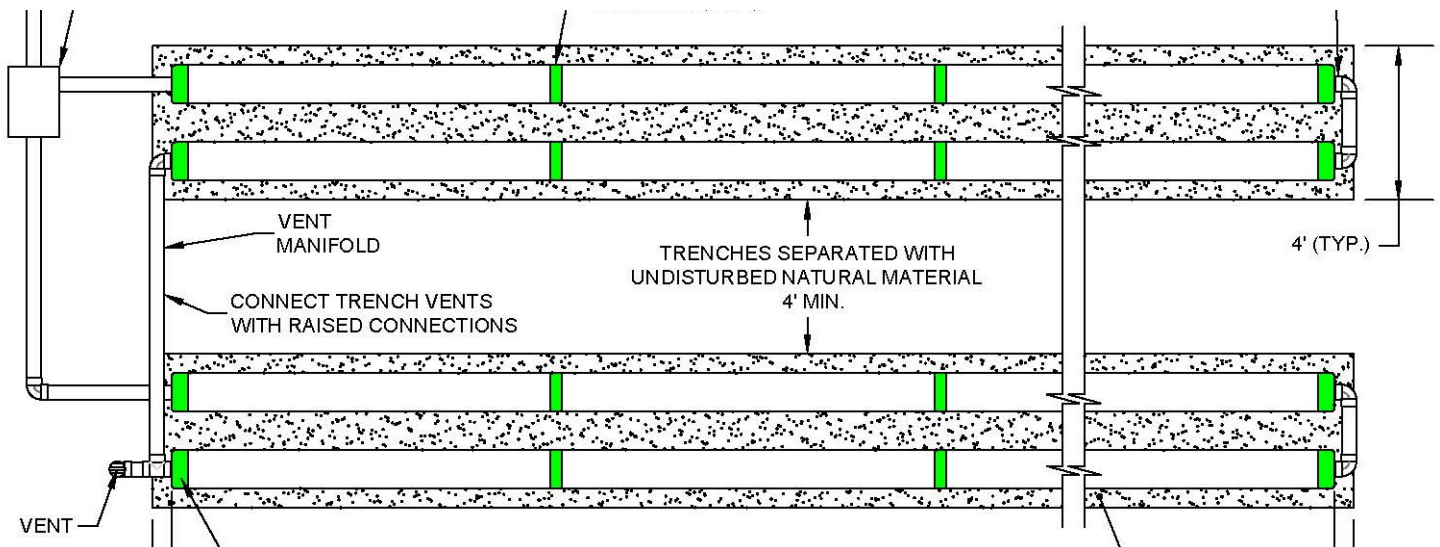

NOTES:

1. Gravelless absorption systems products shall be installed in conformance with manufacturer's instructions.
2. The gravelless trench sidewalls shall be separated by a minimum of 4 feet of undisturbed soil.
3. All gravelless trenches shall be equal in length.

SYSTEM CONFIGURATIONS — Trench Systems

Gravelless Media-Wrapped Corrugated Pipe Sand-Lined Systems – Appendix 75-A.8(c)(3)(ii)

AES pipes may be placed in 2-foot-wide trench configurations for both new and replacement systems. Minimum trench lengths are presented in Table D on page 8. These trench lengths are taken from Table 6C of the Residential Onsite Wastewater Treatment Systems Design Handbook and include a 25% reduction. In addition, the 2-foot-wide trench may also be designed as raised or cut and fill applications. The requirement for use of aggregate is waived.

Cross Section View

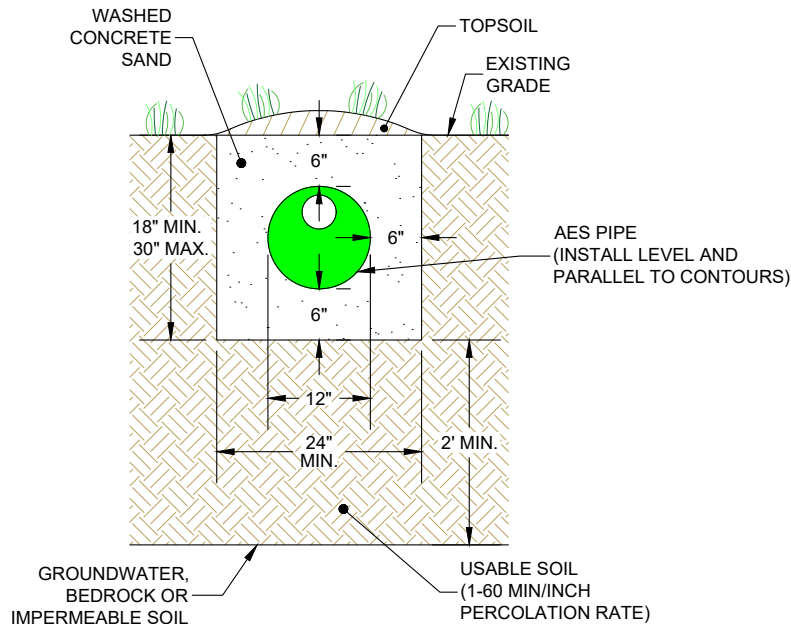

Plan View

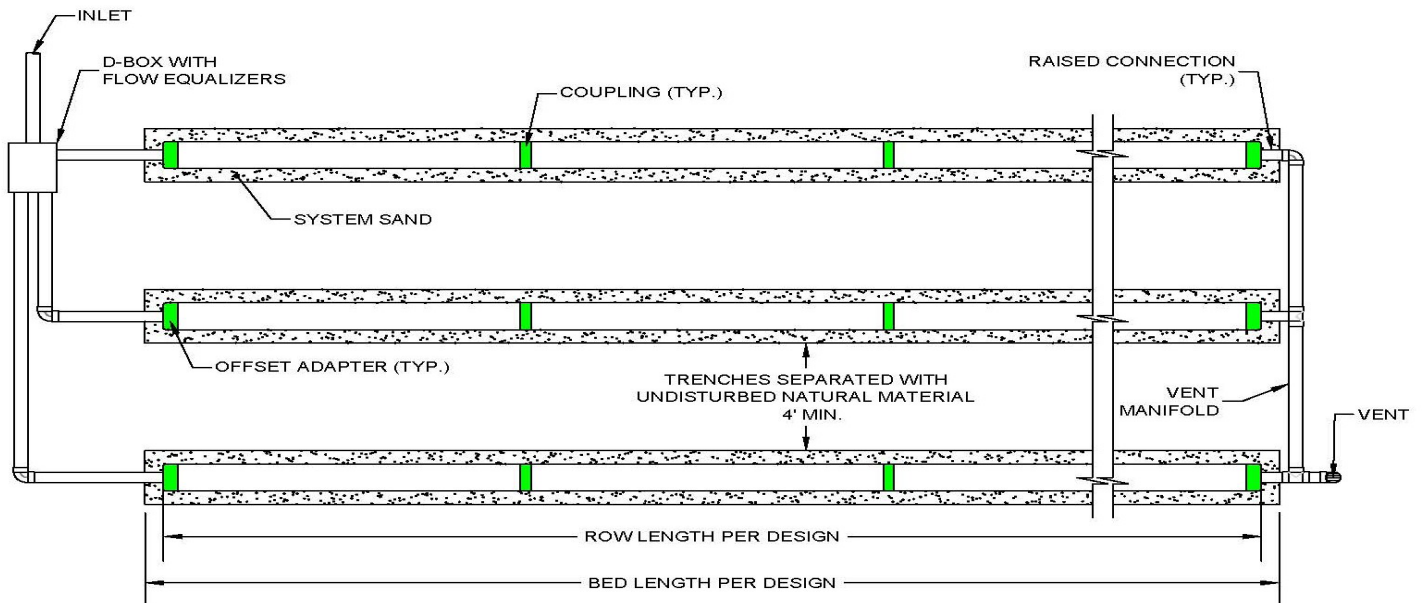

NOTES:

1. Gravelless absorption systems products shall be installed in conformance with manufacturer's instructions.
2. The gravelless trench sidewalls shall be separated by a minimum of 4 feet of undisturbed soil.
3. All gravelless trenches shall be equal in length.

Shallow Absorption Trench System – Appendix 75-A.8(e);

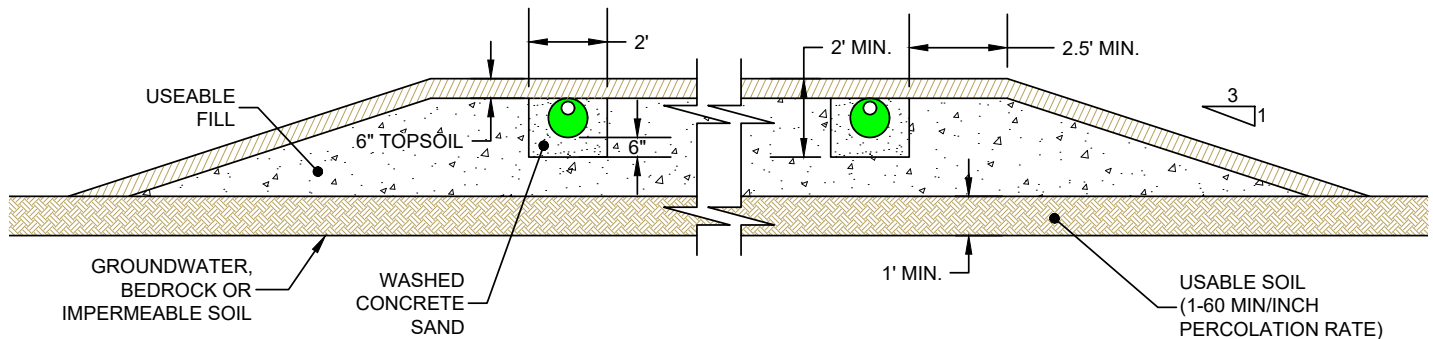

NOTES:

1. Bottom of all trenches shall not be above original usable soil and should preferably be at least 6 inches below original grade.
2. Usable fill should have a percolation rate similar to but not faster than the usable soil percolation rate.
3. Maximum depth of usable fill plus six (6) inches of topsoil shall not exceed 30 inches.
4. Trench bottoms shall be level. Trenches shall be parallel to ground contours.
5. On sloped sites, a diversion ditch shall be constructed uphill from the fill to prevent surface runoff from entering the fill.
6. Extend fill at least 6 feet beyond edges of trenches before starting 1 on 3 edges of fill.
7. Heavy equipment shall be kept out of the absorption area.
8. Fill material is carefully placed within the absorption area.

Cut and Fill System

The AES System may be designed and installed as a raised system as outlined in Appendix 75-A.8 (f)

Raised System

The AES System may be designed and installed as a raised system as outlined in Appendix 75-A.9 (b)

SYSTEM CONFIGURATIONS — Bed Systems

Absorption Bed System– Appendix 75-A.9(g).

Absorption bed systems operate on a principal similar to the absorption trench except that several laterals are installed in a single excavation. AES may be designed and installed as an absorption bed system with or without the use of pressure distribution. The requirement for the use of pressure distribution in an AES bed system has been met through the incorporation of the Bio-Accelerator fabric. The Bio-Accelerator provides surface area for the formation of a bio-mat layer that promotes even distribution throughout the system without the use of pressure distribution piping. If pressure distribution piping is included in the system design, it is installed within the AES conduit.

Level Absorption Bed System:

Cross Section View

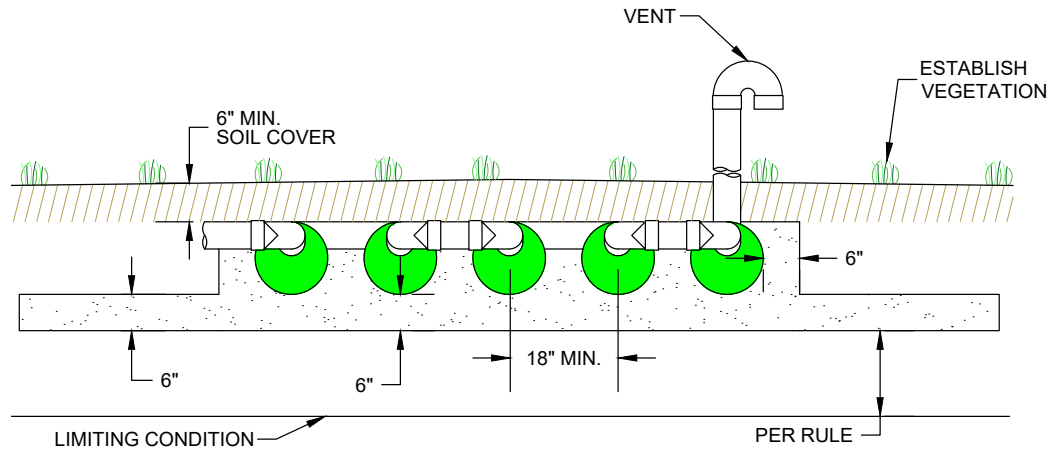

Plan View

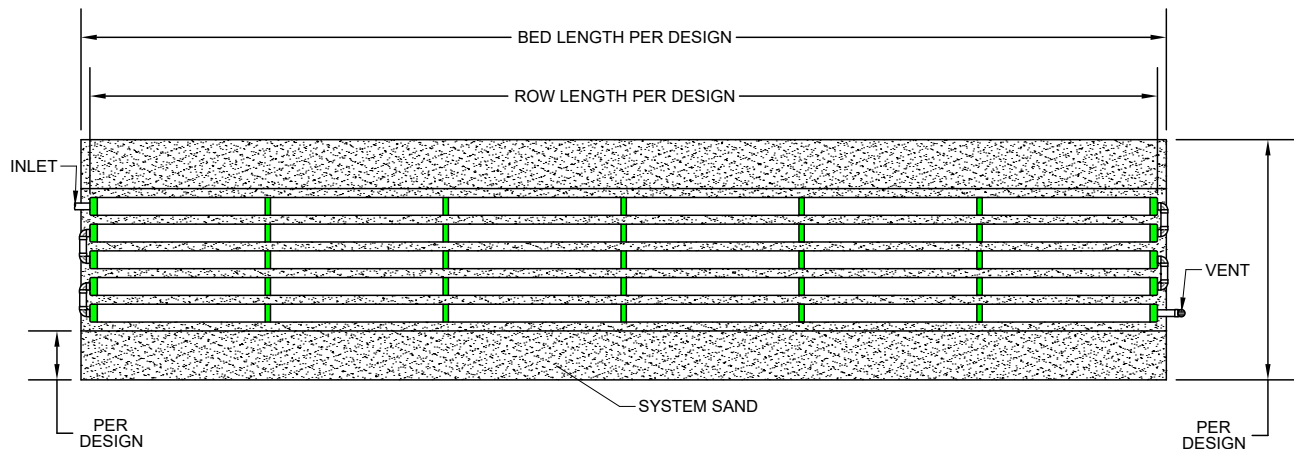

NOTES:

1. Number and length of conduits per design.
2. Pumping is not required unless gravity flow cannot be achieved.
3. Observation ports are required (Inspection port not shown in above picture).
4. AES pipe may be bent up to 90°.

SYSTEM CONFIGURATIONS — Bed Systems

Sloped Absorption Bed System: Cross Section View

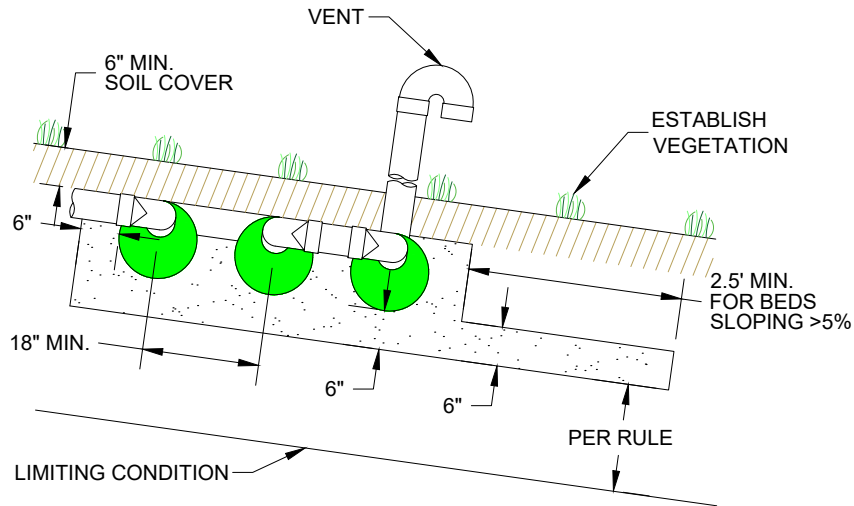

Plan View

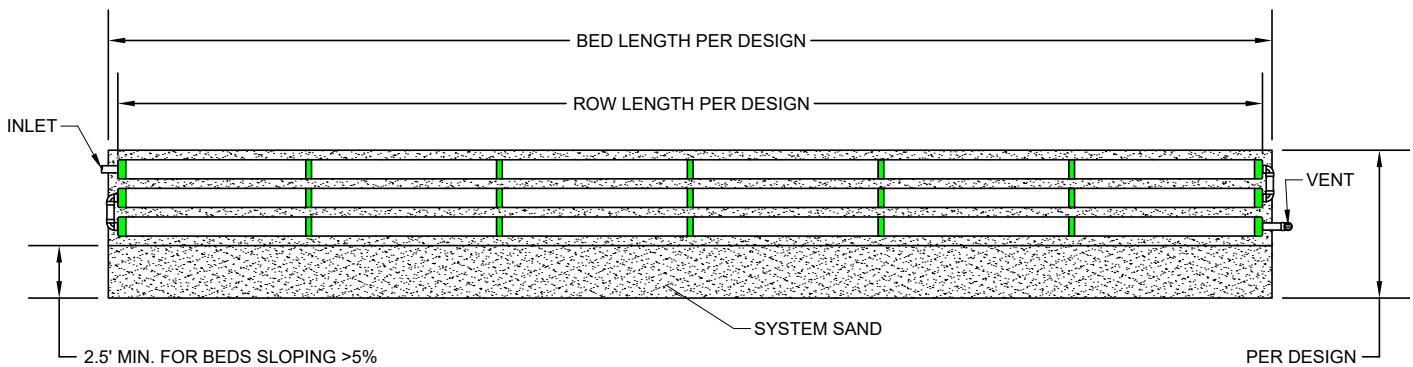

Mound System – Appendix 75-A.9(c)

As an approved gravelless media-wrapped corrugated pipe sand-lined system, AES may be designed and installed in raised system applications or mound system applications, both with or without the use of pressure distribution. In these applications, the 25% absorption trench length reduction is not applicable to system design and the requirement for the use of aggregate is waived. If pressure distribution piping is included in the system design, it is installed within the AES conduit.

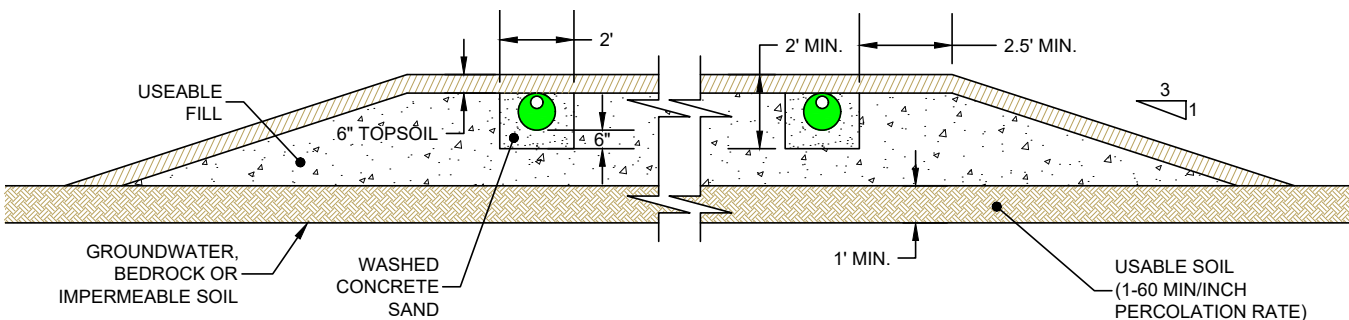

NOTES:

1. Number and length of conduits per design.
2. Pumping is not required unless gravity flow cannot be achieved.
3. Observation ports are required (Inspection port not shown in above picture).
4. AES pipe may be bent up to 90°.

SYSTEM CONFIGURATIONS

Angled and Curving Systems

Angled and curving systems are used to avoid obstacles and work well around structures, setbacks, and slopes. Multiple curves can be used within a system to accommodate various contours of tight site.

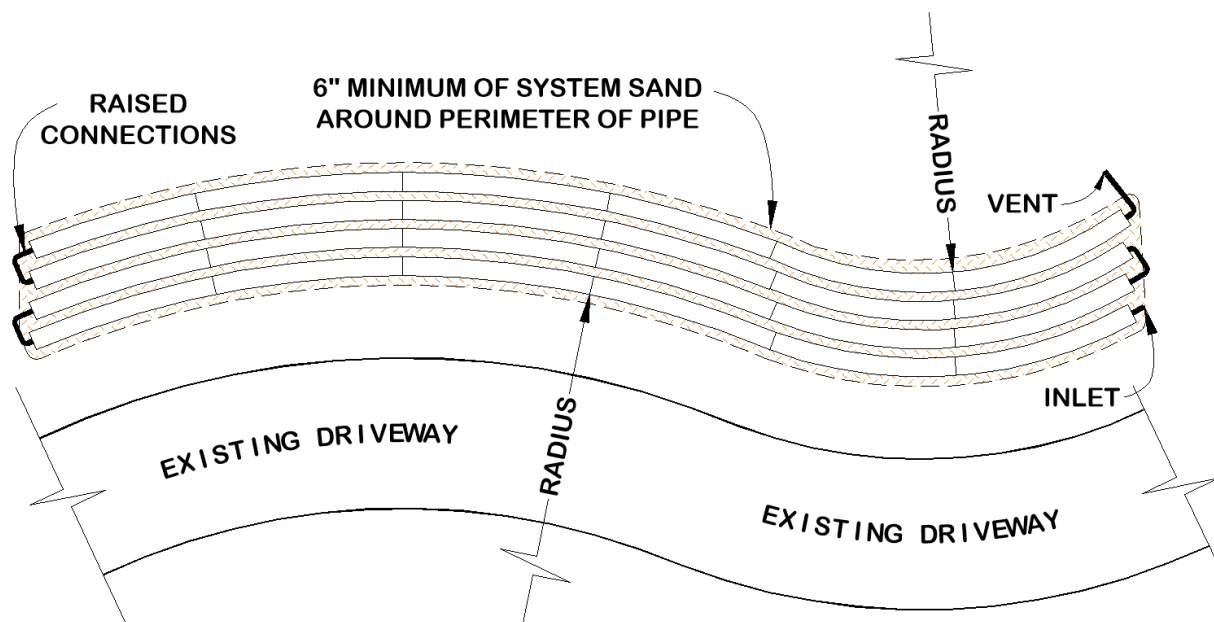
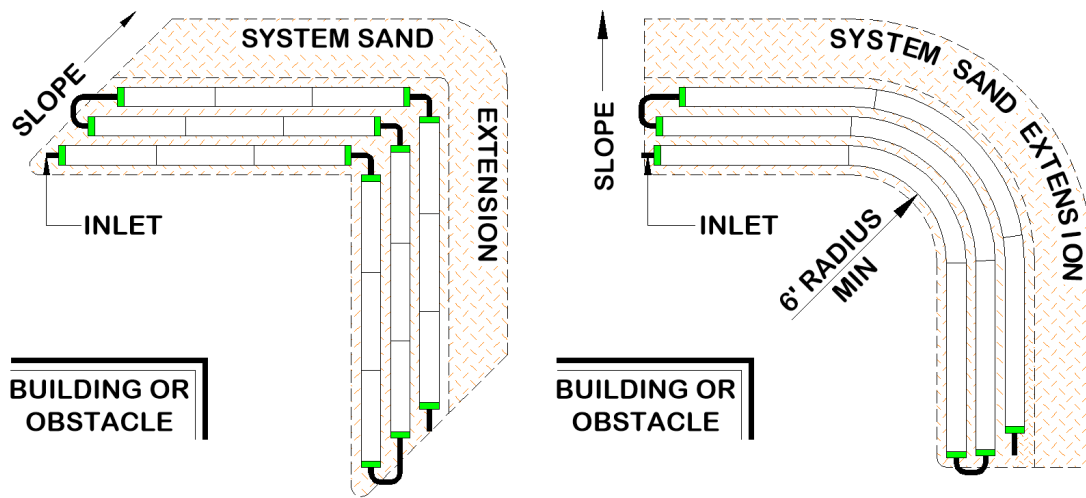

NOTES:

1. Number and length of conduits per design.
2. Pumping is not required unless gravity flow cannot be achieved.
3. Observation ports are required (Inspection port not shown in above picture).
4. AES pipe may be bent up to 90°.

Before You Begin

AES may only be installed according to these instructions, as well as all applicable state and local health permitting authority requirements.

If unsure of the installation requirements for a site, contact your permitting authority. If unsure of the applicability of AES for a given site, contact Infiltrator Water Technologies' Technical Services Department. The soil and site evaluation and the design of the onsite system must be reviewed, approved and a construction permit obtained from the local permitting authority before installation.

Materials and Equipment Needed

- AES pipe
- Couplings
- Offset adapters
- System sand
- PVC pipe and couplings
- Backhoe / Excavator
- Laser, Transit, or Level
- Shovel and Rake
- Tape Measure

These guidelines for construction machinery must be followed during installation:

- Avoid direct contact with AES pipe when using construction equipment. AES pipe require a 12-inch minimum of compacted cover to support a wheel load rating of 16,000 lbs/axle or equivalent to an H-10 AASHTO load rating.
- Only drive across the system when necessary.
- Never drive down the length of the system.
- To avoid additional soil compaction, never drive heavy vehicles over the completed system unless it is installed in H-20 applications.

Component Handling

Keep mud, grease, oil, etc. away from all components. Avoid dragging pipe through wet or muddy areas. Store pipe on high and dry areas to prevent surface water and soil from entering the pipes or contaminating the fabric prior to installation. The outer fabric of the AES pipe is ultra-violet stabilized; however, this protection breaks down after a period of time in direct sunlight. To prevent damage to the fabric, cover pipe with an opaque tarp if stored outdoors.

Site Preparation Prior to Excavation

1. Locate and stake out the system sand bed, extension areas and soil material cover extensions on the site according to the approved plan.
2. Install sediment/erosion control barriers prior to beginning excavation to protect the system from surface water flows during construction.
3. Do not stockpile materials or equipment within the portion of the site receiving system sand.

Critical Reminder to Prevent Soil Compaction

It is critical to keep excavators, backhoes, and other equipment off the excavated or tilled surface of a bed. Before installing the system sand, excavation equipment should be operated around the bed perimeter; not on the bed itself. It is especially important to avoid using construction equipment down slope of the system to prevent soil compaction.

When to Excavate

Do not work wet or frozen soils. If a fragment of soil from about 9 inches below the surface can easily be rolled into a wire, the soil moisture content is too high for construction. Do not excavate the system area immediately after, during, or before precipitation.

Raking and Tiling Procedures

All areas receiving system sand, sand fill, side-slope tapering and fill extensions shall be mechanically tilled or raked with chisel teeth to remove organic material. After the bed bottom has been prepared, blend a shallow layer of system sand with the tilled surface to ensure effluent acceptance into the soil.

NOTE: It is not necessary for the soil of the system site to be smooth when the site is prepared.

Install System Sand and/or Sand Fill Immediately After Excavation

- To protect the tilled area from damage by precipitation, system sand should be installed immediately after tilling.
- Work off either end or the uphill side of the system to avoid compacting soil.
- Install system sand a minimum of 6 inches deep to the elevation where the bottom of AES pipes will be and install the sand for side slope tapering, if system is above grade, to allow machinery movement around the perimeter of the system.
- Heavy equipment with tires shall never enter the receiving area due to likely wheel compaction of underlying soil structures.

Row Installation Sequence

1. Rake the system sand where the AES pipes will be installed so it is as level as possible before placing pipes on the system sand. This will make it easier to level the pipe rows.
2. Locate AES rows horizontally with the Bio-Accelerator (white geo-textile fabric) positioned in the center along the bottom of the pipe rows (sewn seam up).
3. Locate AES rows vertically using a laser level or transit. Lift or lower the pipes at couplings using a hand shovel and adding or removing system sand as necessary.
4. Drop system sand along each row of couplings being careful to avoid moving the rows.
5. Add or remove system sand along rows to level. The rows may be raised by pushing additional system sand below the pipes. A hand shovel may be scraped along the system sand below the pipes to remove a small amount if needed.

INSTALLATION INSTRUCTIONS

6. Re-check horizontal and vertical locations. Re-check that pipes are level to within 1 inch end-to-end. Variations beyond 1 inch ($\pm\frac{1}{2}$ inch) are not acceptable.
7. Add system sand between and around the AES pipes, leaving the uppermost surface of the pipe exposed to allow for system inspection (if required by local approving authority).

Row Spacers

System sand may be used to keep pipe in place while covering, but simple tools may also be constructed for this purpose. Two examples are shown. One is made from wood, the other from rebar.

CAUTION: Remove all tools used as row spacers before final covering.

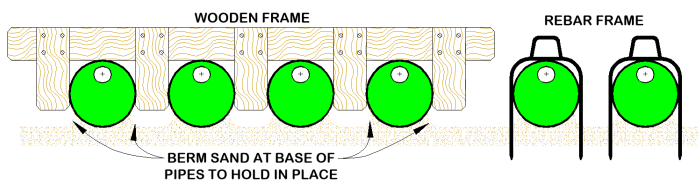

Connect Rows Using Raised Connections

Raised connections consist of offset adapters, 4 in PVC sewer and drainpipe, and 90 degree elbows. They enable greater liquid storage capacity and increase the bacterial surfaces being developed. Use raised connections to connect the rows of the AES system.

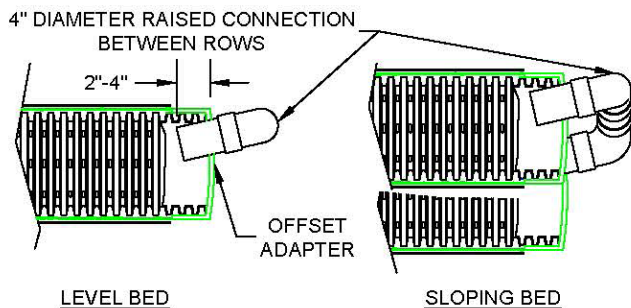

Backfilling Rows

1. Confirm pipe rows are positioned with Bio-Accelerator along the bottom (sewn seam up).
2. Spread system sand between the rows.
3. Straddle each row of pipe and walk heel-to-toe its entire length, ensuring that system sand fills all void spaces beneath the AES pipe.
4. Finish spreading system sand to the top of the rows and leave them exposed for inspection purposes.
5. Confirm that all rows of pipe are level to within 1 inch end-to-end.
6. After inspection (if required) proceed to backfilling and final grading.

Backfilling and Final Grading

1. Spread system sand to the top of the AES pipe and a minimum of 6 inches on all four sides of the bed beyond the AES pipes as specified in the design.
2. Spread a minimum of 6 inches of suitable earth cover (topsoil or loam) having a texture similar to the soil at the site, without causing compaction. It is best to crown several extra inches of soil over the finished grade to allow for settling after installation.
3. To prevent erosion, soil cover above the system shall be planted with shallow-rooted vegetation.

Fill Extension Requirements

All systems with any portion of the system sand bed above original grade require 6-inch fill extensions on each side beyond the outside edge of all AES pipes and then tapering to meet existing grade at a maximum slope of 2:1. For systems sloping over 5%, the downslope side tapers at a maximum of 3:1. Naturally-occurring soils removed when excavating the site may be used for constructing side slope tapering, provided the soil contains no organics, stones larger than 6 inches, stumps or other debris.

Information for System Owners

Basic rules of onsite sewage treatment system use and care apply to the AES System.

System Use and Abuse

Your Infiltrator AES System is intended for use with residential-strength wastewater within the design daily flow volume. To ensure long-term function of your system:

- Keep daily wastewater flow within design parameters
- Do not connect the rainwater management system to the Infiltrator AES System.
 - Direct water from the rainwater management system away from the Infiltrator AES System.
- Introduce only normal residential wastewater into the system
 - Solvents, paint, pharmaceuticals, aggressive cleaning products, and non-biodegradable items should not enter the Infiltrator AES System.
 - Solids, such as but not limited to, cigarette butts, diapers, feminine hygiene products, cat litter, and paper towels should not be introduced into the Infiltrator AES System.
- Maintain leak-free household plumbing fixtures, such as faucets and toilets.
- Do not utilize a garbage grinder.
- Unless designed and installed in an H-20 configuration, the AES System is intended for use in non-traffic applications. Therefore,
 - Do not allow heavy equipment or vehicles to drive over the system;
 - Install protections to prevent exposure of the system to inadvertent heavy equipment or vehicular loading
- Do not build structures on top of the system

Site Maintenance

It is important that the system site remain free of shrubs, trees, and other woody vegetation, including the entire SSBA, and areas impacted by side slope tapering and perimeter drains (if used). Roots can infiltrate and cause damage or clogging of system components. If a perimeter drain is used, it is important to make sure that the outfall pipes are screened to prevent animal activity. Also check outfall pipes regularly to ensure that they are not obstructed in any way.

Operation and Maintenance

AES systems do not require a maintenance and monitoring agreement, however they do require minimal maintenance as is standard for conventional onsite systems, provided the system is not subjected to abuse. An awareness of proper use and routine maintenance will guarantee system longevity.

Maintenance of the Infiltrator AES System includes the following general soil absorption system maintenance:

- Ensure all surface water is directed away from trenches.
- Walk trenches regularly to check for "soft spots."
- Check for ponding in distribution area, surface water infiltration, and vegetative cover erosion.
- Keep all heavy machinery and vehicles off of leach field.
- Do not plant trees or heavy rooted vegetation near leachfield.
- If equipped, rotate distribution device(s) semi-annually to allow resting.
- If the septic tank has an effluent filter, it should be cleaned seasonally
- The septic tank should be pumped and inspected on a regular basis (every 2-5 years) and, if concrete, checked for leaks and cracks. The interval for septic tank pumping varies depending upon use. Check with a qualified onsite wastewater system professional or your local health department for the appropriate pumping interval.

If at any time you have concerns about the use, operation, or maintenance of your Infiltrator AES System, contact the Infiltrator Water Technologies Technical Department at (800) 221-4436.

OPERATION AND MAINTENANCE

Information for Service Providers

All AES Systems shall be operated and maintained in accordance with the Operation and Maintenance information provided herein.

Septic Tank/Pumping Chamber Maintenance:

- Routine pumping and inspection of the septic tank (every 2-5 years)

Soil Absorption Area:

- Ensure all surface water is directed away from absorption area.
- Walk absorption area to check for “soft spots.”
- Keep all heavy machinery and vehicles off leach field.

The service provider shall also conduct additional observations, measurements, monitoring, and maintenance activities for any system component (septic tank, pump tank, controls, soil absorption component, etc.), as specified in the operation permit and as recommended by the manufacturer.

Trouble Shooting

In the event that any of the following indicators arise, contact a qualified onsite wastewater system professional.

- Wastewater back-up into the dwelling
- Persistent septic odor
- Unusually wet area atop and/or around the system
- “Ponding” of effluent on the lawn
- “Breakout” of effluent along the side of a slope or other landscape feature

Bacteria Rejuvenation and Expansion

Bacteria rejuvenation is the return of bacteria to an aerobic state. Flooding, improper venting, alteration or improper depth of soil material cover, use of incorrect sand, sudden use changes, introduction of chemicals or medicines, and a variety of other conditions can contribute to converting bacteria in any system from an aerobic to an anaerobic state. This conversion severely limits the bacteria's ability to effectively treat effluent, as well as limits liquids from passing through. A unique feature of the AES system is its ability to be rejuvenated in place.

How to Rejuvenate System Bacteria

System bacteria are “rejuvenated” when they return to an aerobic state. By using the following procedure, this can be accomplished in most AES systems without costly removal and replacement.

1. Contact Infiltrator's Technical Services Department before attempting rejuvenation for technical assistance.
2. Determine and rectify the problem(s) causing the bacteria conversion.
3. Have system and septic tank pumped by a registered septage pumper.
4. Drain the system by excavating at least one end of all the rows and removing the offset adapters.
5. If foreign matter has entered the system, flush the pipes.
6. Safeguard the open excavation.
7. Guarantee a passage of air through the system.
8. Allow all rows to dry for 72 hours minimum. The system sand should return to its natural color.
9. Re-assemble the system to its original design configuration. If there is no physical damage to the AES components, the original components may be reused.

(a) The structural integrity of each unit, endcap and other accessory manufactured by Infiltrator (collectively referred to as "Units"), when installed and operated in an onsite wastewater system in accordance with Infiltrator's installation instructions, is warranted to the original purchaser ("Holder") against defective materials and workmanship for one year from the date upon which a septic permit is issued for the septic system containing the Units; provided, however, that if a septic permit is not required for the septic system by applicable law, the one (1) year warranty period will begin upon the date that installation of the septic system commences. In order to exercise its warranty rights, Holder must notify Infiltrator in writing at its corporate headquarters in Old Saybrook, Connecticut within fifteen (15) days of the alleged defect. Infiltrator will supply replacement Units for those Units determined by Infiltrator to be defective and covered by this Limited Warranty. Infiltrator's liability specifically excludes the cost of removal and/or installation of the Units.

(b) THE LIMITED WARRANTY AND REMEDIES IN SUBPARAGRAPH (a) ARE EXCLUSIVE. THERE ARE NO OTHER WARRANTIES WITH RESPECT TO THE UNITS, INCLUDING NO IMPLIED WARRANTIES OF MERCHANTABILITY OR FITNESS FOR A PARTICULAR PURPOSE.

(c) This Limited Warranty shall be void if any part of the AES System components (unit, endcap or other accessory) is manufactured by anyone other than Infiltrator. The Limited Warranty does not extend to incidental, consequential, special or indirect damages. Infiltrator shall not be liable for penalties or liquidated damages, including loss of production and profits, labor and materials, overhead costs, or other losses or expenses incurred by the Holder or any third party. Specifically excluded from Limited Warranty coverage are damage to the Units due to ordinary wear and tear, alteration, accident, misuse, abuse or neglect of the Units; the Units being subjected to vehicle traffic or other conditions which are not permitted by the installation instructions; failure to maintain the minimum ground covers set forth in the installation instructions; the placement of improper materials into the system containing the Units; failure of the Units or the septic system due to improper siting or improper sizing, excessive water usage, improper grease disposal, or improper operation; or any other event not caused by Infiltrator. This Limited Warranty shall be void if the Holder fails to comply with all of the terms set forth in this Limited Warranty.

Further, in no event shall Infiltrator be responsible for any loss or damage to the Holder, the Units, or any third party resulting from installation or shipment, or from any product liability claims of Holder or any third party. For this Limited Warranty to apply, the Units must be installed in accordance with all site conditions required by state and local codes; all other applicable laws; and Infiltrator's installation instructions.

(d) No representative of Infiltrator has the authority to change this Limited Warranty in any manner whatsoever, or to extend this Limited Warranty. No warranty applies to any party other than the original Holder.

The above represents the standard Limited Warranty offered by Infiltrator. A limited number of states and counties have different warranty requirements. Any purchaser of Units should contact Infiltrator's corporate headquarters in Old Saybrook, Connecticut, prior to such purchase, to obtain a copy of the applicable warranty, and should carefully read that warranty prior to the purchase of Units.

**Contact Infiltrator's Technical Services Department
for assistance at 1-800-221-4436 or info@infiltratorwater.com**

For U.S. Patents information visit www.infiltratorwater.com/patents. Other patents pending. Infiltrator, Quick4 and EZflow are registered trademarks of Infiltrator Water Technologies. Infiltrator Water Technologies is a wholly-owned subsidiary of Advanced Drainage Systems, Inc. (ADS). Not responsible for any typographic errors.