

April 2026

ECODRIP® Series

FILTER/DRIP SYSTEM

INSTALLATION, OPERATION AND MAINTENANCE MANUAL

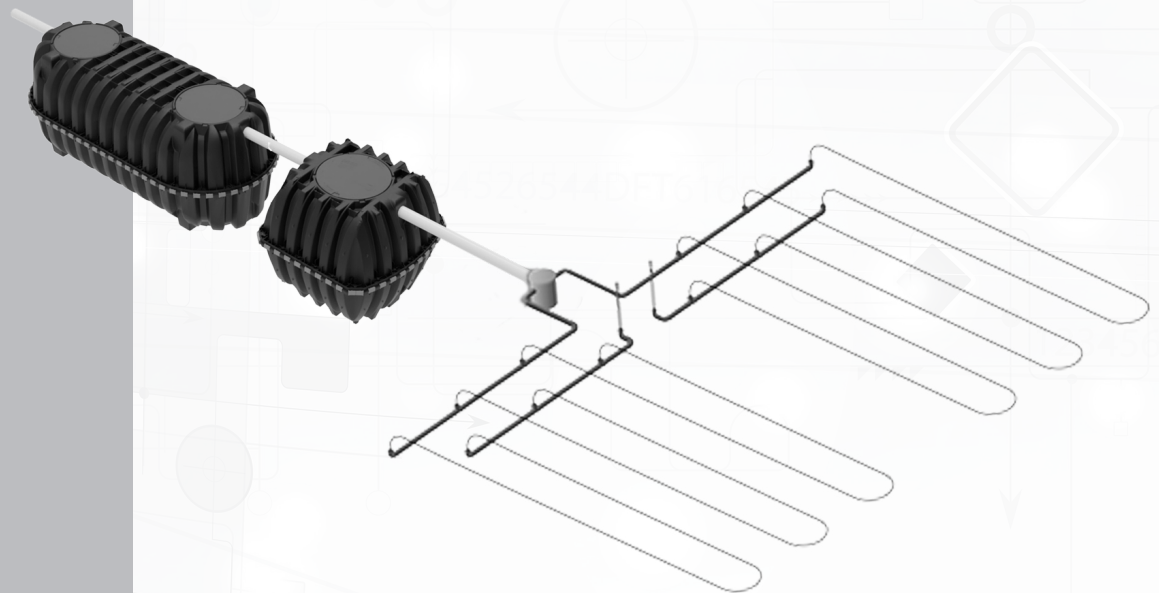

MODELS 8115 and 8230

 **Infiltrator™**
Part of **///ADS**

infiltratorwater.com • (800) 221-4436

DISTRIBUTOR AND HOMEOWNER NOTES

The Infiltrator ECODRIP Filter/Drip System is designed to filter effluent water discharged from an advanced treatment system that is listed by the National Sanitation Foundation (NSF) in accordance with NSF/ANSI Standards 40 or 245, Class 1 effluent requirements.

Consult your local Sanitarian/Regulatory Agency prior to installation.

HOMEOWNER RECORDS

DATE: _____

INSTALLED BY: _____

DISTRIBUTOR: _____

The ECODRIP System has been designed and built to provide long term, reliable and efficient service. Once the unit has been installed (see installation instructions) the unit will operate with a minimum amount of attention. The following checks should be made periodically as described:

CAUTION: USE LATEX PROTECTIVE GLOVES WHEN HANDLING EFFLUENT WASTEWATER. AVOID GETTING ANY EFFLUENT WATER ON YOU. WASH UP WITH ANTI-BACTERIAL SOAP WHEN FINISHED.

Reference Treatment System Manual

Periodically: – Solids Removal

Please refer to your treatment system's manual for operation and maintenance instructions

DURING THIS PROCEDURE IT IS IMPORTANT THAT CARE IS TAKEN TO PREVENT ANY SOLIDS FROM DISCHARGING INTO THE DOSING TANK.

- During pump out of treatment plant, pump out the lower 25 percent of the dosing tank to remove any solids that would have accumulated on the bottom.
- Any sludge removed from system must be disposed of according to all state, local, and federal regulatory requirements.
- The alarm to the dosing tank is activated when there is a high water situation in the dosing tank. This could indicate a problem with the filter system, dosing pump, or pump float level switches. Observe if dosing pump is operational. Turn the Hand-Off-Auto switch located in the control panel to the hand position. This will override the PLC timer and turn the pump on if operational. There is a 2 minute delay after power up before pump start. Observe the water meter located in the filter box for flow. If the flow is less than that at the time of installation, it is possible the filter requires cleaning. Disconnect power to the filter control panel. The filter is located in the filter box. Unscrew the filter canisters and remove the filter element in the filter housing. Wash filter with clean water and reinstall into the canister. Turn the switch to the hand position and observe the water meter, again there is a 2 minute time delay before pump run. Flow would have been reduced if the filter were excessively dirty. After a period of time, observe if alarm stops sounding. This will indicate whether or not the system has returned to normal operation. Turn the switch back to the automatic position.

General Operation

1. Upon power up at panel there is a 2 minute time delay before the pump starts.
2. After this time delay, the pump will start and run for a set period of time, then turn off for another set period of time.
3. When the pump starts, the filter flush valve will open for a set period of time then close.
4. After a set number of pump starts, the field flush valve will open for a set period of time after the pump starts and after the filter flush valve closes.

5. The field flush cycle will repeat itself on each subsequent pump cycle for the number of fields connected to the system before resetting.

6. In a normal cycle, the field flush valve can be opened for a period of 60 seconds by momentarily pushing the "Field Flush" toggle switch up then releasing it. This can be repeated for additional flushes.

7. At the end of each pumping cycle, after the pump shuts off, both the filter flush and field flush valves will open for a set period of time then close.

Description Of Control Floats

1. Float FS1 is a wide angle float that when up, permits the pump to run and when down, keeps the pump from running and pumping dry. Note that by placing the HAND-OFF-AUTO switch in HAND position, will by-pass all floats and the pump will pump dry if held in that position long enough. The switch spring returns to OFF when released. After FS1 activates, there is a one minute delay before the pump will start if being called to run before the float activates.
2. Float FS2 is the override timer reset float and FS3 is the override timer float. These floats operate together. If the water level reaches FS3 while in an OFF period, the pump will start and the OFF period time will change to the setting in block B02. The run time remains as set in B01. The shorter OFF time will remain until the water level reaches FS2 after which the OFF time reverts back to the normal B01 setting.
3. Float FS4 is the high level alarm float. When the water level reaches this float, the high level alarm light illuminates continuously, and the audible alarm sounds continuously. The audible alarm can be silenced by the silence switch. When the high level water level recedes, the alarm will stop.
4. Float FS5 is an optional float that can be installed below FS1 that will cause an alarm at low water level. Low level alarm operation is identical to the high level alarm operation except the alarm light will flash and the audible alarm will sound intermittently.
5. Floats FS2, FS3, FS4 can be low current, normally open. FS1 must be of the wide angle type. FS5 can be low current, normally closed.

- If no flow has been observed, call your local dealer for service.

CAUTION: EXCESSIVE MANUAL OVERRIDE MAY CAUSE WATER TO SURFACE AT THE GRID SYSTEM. MANUAL OVERRIDE MUST NOT EXCEED 10 MINUTES EVERY 2 HOURS.

NOTE: To keep maintenance to a minimum and ensure high effluent quality, the following items should not be permitted to enter the system:

- Strong disinfectants or bleaches, other than small amounts normally utilized in day to day cleaning and laundry (be conservative). Use low-sudsing, low phosphates and biodegradable laundry detergents.
- Discharge from water softener
- Any type of oils, greases, or other chemical wastes
- Disposable baby diapers and wipes
- Sanitary napkins, condoms or other similar devices

CARE AND OPERATION INSTRUCTIONS

- Hair, bandages, rags, or string
- Latex, plastic, or metallic objects
- Coffee grounds or cigarette butts
- Mud or sticks
- Paper towels, napkins or Kleenex
- Excessive use of water over the design flow of the system, or organic overloading in excess of design parameters
- The proper operation of this or any other home sewage system depends upon proper organic loading and the life of the microorganisms inside the system. Infiltrator is not responsible for the in-field operation of the system, other than the mechanical and structural workings of the system itself. We cannot control the amount of harsh chemicals or other harmful substances that may be discharged into the system by the occupants of a household.

CALIFORNIA PROPOSITION 65 WARNING:
This product and related accessories contain chemicals known to the State of California to cause cancer, birth defects or other reproductive harm.

HOW THE ECODRIP FILTER SYSTEM WORKS

The ECODRIP Filter/Drip System consists of the following basic items:

1. Secondary Wastewater Treatment System
2. Dose Tank per State Requirements
3. High Head Turbine Pump
4. ECODRIP Filter Headworks System
5. Valves
6. PLC Controls and Alarm Panel
7. Subsurface Drip Tubing and Accessories per Table 1

Treated effluent water from the secondary wastewater treatment system spills into an underground dose tank that is sized in accordance with State requirements. Treated water is temporarily stored in the dose tank until disposal in the drip disposal field.

The control panel contains a programmable logic controller (PLC) that periodically turns the pump, located inside the dose tank, on and off. The pump moves water from the dose tank to the filter located inside a ground level box. The filter removes all particles greater than 100 microns (150 mesh) in size. At the beginning of each pumping cycle, the PLC turns the pump on, and sequentially opens and closes the flush valve that allows the filter to wash for a set period of time, after which the water is pumped through the filter to the disposal system. Approximately once per week (field adjustable), the system field flush valve opens to flush the disposal system of any solids that have built up. Sequential flushing is done for each zone during subsequent pump cycles. The flush water along with any impurities removed by the filter is returned to the wastewater treatment plant for further treatment. The control panel is furnished with a Hand-Off-Auto switch located in the panel. The hand mode overrides the PLC timer so the pump can be manually turned on. When the level of water in the dosing tank is low, the pump float switch will be in the off position, disabling the pump. The control panel also contains a high level alarm that will sound if a high level is reached in the dose tank which may indicate a system malfunction.

The filtered effluent is pumped through the supply line to flexible polyethylene tubing with large turbulent flow labyrinth or pressure compensating emitters uniformly spaced along the line. Effluent is uniformly distributed over the entire absorption field using a low flow rate.

Absorption field size is determined by, soil type, site characteristics and daily wastewater flow. The field size varies depending on soil texture and permeability. The absorption field should be situated on the best soil and landscape position of the site. Separation between the bottom of the emitter pipe and any underlying restrictive horizons (seasonably high water table) can be as little as 6 inches or as regulations require. The emitter lines should be installed between 6 and 18 inches deep depending on soil and site characteristics.

An absorption field installed on slopes should be carefully designed to take into consideration elevation changes and emitter line placement due to gravitational pressures. The treatment plant, dosing tank and filter unit should not be placed in low areas in order to prevent subsurface or surface runoff from returning or flooding the units.

Once the soil and site evaluation has been completed, the most suitable location and size of the absorption field is selected. Depending on the hydraulic loading rate of the soil, the linear feet of emitter pipe and number of zones are determined. It is also important that each zone is placed along the ground contour. The configuration of the zones may vary in shape.

The PLC controller must be set in the field as system flow and the number of zones will vary from site to site. The pump run time is factory set, but can be changed in the field.

The number of pump cycles is factory set at 12 per day (field adjustable).

Example Using Geoflow® Classic Tubing:

System flow – 600 gallons per day (GPD)
Total length of emitter pipe – 1260 feet
Number of zones - 2 at 630 feet each
Number of pump cycles – 12 (factory set)
Zone capacity – 6.4 gallons per minute (GPM)
Number of gallons pumped per pump cycle =
 $600 \text{ GPD} \div 12 \text{ pump cycles per day} = 50 \text{ gal. per pump cycle}$

Run Time =
 $50 \text{ gallons per pump cycle} \div 6.4 \text{ GPM} = 7.81 \text{ minutes}$

Using a safety factor of 1.5, set time at $1.5 \times 7.81 = 12 \text{ min.}$

Pre-Engineered Subsurface Drip Disposal Systems
by Infiltrator Treatment Systems

TABLE 1

8115-1/2 HP CP8115 Control Panel with 1/2 HP Pump

Drip Tubing	Drip Tube per Zone	Laterals per Zone	Length per Lateral	Max. Number of Zones per System	Pressure Regulator	Zone Discharge in GPM
Geoflow® Classic	630	3	210	6	20 PSI	6.4
Geoflow® PC .53	1,320	6	220	6	20 PSI	5.8
Geoflow® PC 1.01	750	3	250	6	20 PSI	6.3
Netafim Bio-Line PC .61	1,200	3	400	6	20 PSI	6

8230-1 HP CP8230 Control Panel with 1 HP Pump

Drip Tubing	Drip Tube per Zone	Laterals per Zone	Length per Lateral	Max. Number of Zones per System	Pressure Regulator	Zone Discharge in GPM
Geoflow® Classic	1,500	7	215	6	20 PSI	15.3
Geoflow® PC .53	2,400	8	300	6	40 PSI	10.6
Geoflow® PC 1.01	1,750	6	250	6	40 PSI	14.6
Netafim Bio-Line PC .61	2,100	7	300	6	40 PSI	10.7

NOTE: Each system is designed to be hydraulically balanced with a maximum 300 feet of supply line between the pump and the inlet to the drip field with a maximum elevation difference of 30 feet.

SIZE OF THE ABSORPTION FIELD

The total size of the absorption area depends on the daily wastewater flow and the absorption capability of the soil.

1. Determine the estimated daily flow. The local health department will have guidelines for determining residential flows.
2. Determine the loading rate of the soil. The local health department will have guidelines for loading rate per soil conditions. Qualified persons should conduct soil and site evaluations only. After evaluation of the soil, the hydraulic loading rate is established using the appropriate table (USDA soil classes or State approved tables).
3. Calculate the total area necessary for the absorption field with the following equation:

$$\text{Area} = \frac{\text{Daily flow}}{\text{Soil Loading Rate}}$$
4. Determine the total length of the emitter line required in the absorption area. Spacing between laterals is normally 24 inches.

$$\text{Total Absorption Area in Square Feet} = \frac{\text{Total Emitter Line Required}}{\text{Emitter Line Spacing}}$$
5. Determined the layout of the emitter line absorption field. When selecting the layout of the field, always place the emitters along the contours of the ground area, keeping the emitter line lateral runs as close to the same grade as possible. When running a continuous emitter line that requires a loop, make a connection to solid flex pipe to prevent the emitter line from kinking.
6. The ECODRIP 8115-1/2HP drip system is capable of zone sizes as indicated on Table 1. Using two or more zones keeps the pump HP to a minimum.
 The ECODRIP 8230-1HP drip system is capable of zone sizes as indicated on Table 1. Using two or more zones keeps the pump HP to a minimum.
7. The ECODRIP 8115-1/2 HP drip system utilizes a 1/2 HP dosing pump. The ECODRIP 8 8230-1HP drip system utilizes a 1HP-dosing pump.
8. A pressure regulator is furnished and should be installed at the drip grid supply header at each zone. The pressure regulator will provide proper pressure to the emitters.
9. The requirement of flushing the emitter lines, using the 8115-1/2HP or the 8230-1HP, is important so that proper velocities be maintained through the entire system. The supply line from the filter unit to the emitter supply manifold should be as indicated on drawings to reduce the friction loss to a minimum and keep the velocity above 2 feet per second. Each zone must not have more than indicated on Table 1. This will ensure that each lateral will receive a minimum of 1.69 gallons per minute during a flush cycle. The return line is also an integral part of the system and must be sized for minimum friction loss and velocities above 2' feet per second.
10. A hydraulic zoning valve is typically furnished to automate the switching of zones. The simplicity of design and a minimum number of moving parts ensure ease of maintenance and a long service life. The four-outlet model has interchangeable cams for 2, 3, or 4 zone operation. It is important that each zone be of equal size. An absorption field with more than one

zone will be dosed equally. The flushing cycle for multiple zones will be in sequential pump starts to ensure that each zone is flushed. Check valves are required to isolate each zone in a multiple zone system.

11. Solenoid valves can be used to automate the switching of zones and allow for different dosing times of each zone.
Contact factory for details.

The instantaneous water application rate of the system must not exceed the water absorption capacity of the soil. A determination of the instantaneous water absorption capacity of the soil is difficult; it varies with the water content of the soil. As the soil approaches saturation with water, the absorption rate reduces to an equilibrium rate called the "saturated hydraulic conductivity."

Long-Term Soil Textural Classes		Long-Term Acceptance Rate
Soil Group (USDA Classifications)		GPD/ft ²
I	Sands (with S or PS structure & clay mineralogy)	0.4
II	Coarse Loams, Sandy Loam (with S or PS Loam structure & clay mineralogy)	0.3
III	Fine Loams, Sandy Clay Loam (with S or PS structure & clay mineralogy)	0.15
IV	Clays, Sandy Clay (with S or PS structure & clay mineralogy)	0.1 – 0.05

Absorption Field Required per 100 Gallons of Wastewater		
Loading Rate	Square Feet	Linear Feet
0.4	250	125
0.3	333	167
0.15	666	333
0.1	1000	500
0.05	2000	1000

HEADWORKS FILTER SYSTEM SPECIFICATIONS

MODEL 8115-1/2HP WITH GEOFLOW® CLASSIC

Operating Parameters

Motor/pump size	1/2 HP (standard)
Pressure at outlet of regulator	20-PSI nominal
Maximum particle size	100 microns
Pump cycles	12 times per day (factory setting)
Electrical requirements	115V/1/60 - 20 amps

Components and Materials

Pump/motor	Stainless steel submersible
Piping system	Schedule 40 PVC
Valves	Glass reinforced nylon
Pressure regulator stainless	Thermoplastic with steel hardware
Control panel	Nema 4X Fiberglass
Solenoid valves	Encapsulated 24 Vac
Filter	150-mesh screen with thermoplastic housing
Dripline	1/2" plastic tubing with nominal 1 GPH turbulent non-compensating emitters

Parts List

Item	Item No.
Dose tank	1
Pump/motor	2
Low level alarm float (normally closed) (optional)	3
Pump on/off permissive float switch	4
Override timer reset float switch (optional)	5
Override timer float switch (optional)	6
High level alarm float switch	7
Vacuum release valve	8
Filter system headworks	9
Filter	10
Filter flush valve	11
Flow meter (optional)	12
Field flush valve	13
Pump access riser	14
Control panel	15
Drip emitter tubing	16
Pressure regulator	17

MODEL 8230-1HP WITH GEOFLOW® CLASSIC

Operating Parameters

Motor/pump size	1 HP (standard)
Pressure at outlet of regulator	20-PSI nominal
Maximum particle size	100 microns
Pump cycles	12 times per day (factory setting)
Electrical requirements	230V/1/60 - 20 amps

Components and Materials

Pump/motor	Stainless steel submersible
Piping system	Schedule 40 PVC
Valves	Glass reinforced nylon
Pressure regulator stainless	Thermoplastic with steel hardware
Control panel	Nema 4X Fiberglass
Solenoid valves	Encapsulated 24 Vac
Filter	150-mesh screen with thermoplastic housing
Dripline	1/2" plastic tubing with nominal 1 GPH turbulent non-compensating emitters

Parts List

Item	Item No.
Dose tank	1
Pump/motor	2
Low level alarm float (normally closed) (optional)	3
Pump on/off permissive float switch	4
Override timer reset float switch (optional)	5
Override timer float switch (optional)	6
High level alarm float switch	7
Vacuum release valve	8
Filter system headworks	9
Filter	10
Filter flush valve	11
Flow meter (optional)	12
Field flush valve	13
Pump access riser	14
Control panel	15
Drip emitter tubing	16
Pressure regulator	17

INSTALLATION INSTRUCTIONS

1. Prepare an excavation with an opening approximately one foot larger than the dose tank and a depth that will allow water to freely flow from the treatment plant into the dose tank. Backfill with a 6 inch layer of sand or gravel if otherwise unable to provide a smooth, level, compact base. Install the pump access pipe into the dose tank through the top of the tank and seal. Provide a sufficient length of pipe to extend into the pump access riser about 4 inches. We recommend that the hole be roped off in some fashion to prevent injury to passersby.
2. Fill the dose tank with clean water before back filling. Backfill around the tank approximately 12 inches below ground level. Backfill material should be placed in 12 inch layers and tamped to insure maximum skin friction between dose tank and surrounding ground.
3. Position the electrical conduit in the ground between the pump access riser and the filter box. Drill a 1- 3/4" hole in the pump access riser for the pump outlet pipe and a 7/8" hole for the electrical conduit. Install round pump access riser filter system access box so that they are flush with ground level, and high enough to prevent surface water from entering them.
4. Install a schedule 40 PVC pipe of sufficient length to extend from the pump into the round pump access pipe and have enough room to attach the vacuum release valve and union. Install the vacuum release valve and union using appropriate fittings.
5. Attach the float switches to the discharge pipe using clamps furnished by Infiltrator. Adjust the position of the clamps as shown on the drawings or as required to insure that the pump stops at the minimum operating water level and turns on at about 1'-0" above this level, and that the alarm sounds at high level position. Set the other floats where shown (optional).
6. Install the entire pump assembly through the pump access riser. Install the electrical cables and connect the union from the pump outlet to the filter system. Use silicon to seal around exiting piping.
7. Connect the filter system outlet pipe to the drip line pressure regulator that attaches to the supply manifold. Connect the drip line return manifold to field flush valve, located in the filter assembly. Connect the outlet of the field flush valve to the inlet of the treatment system.
8. Attach control panel to suitable mounting surface using all four mounting holes on back of enclosure. Use proper screws of sufficient length to insure a secure and permanent mounting.
9. Control panel is rated for outdoor service, however do not place it where it can be immersed in rising water or where run-off water such as from a roof will fall on it. Also do not mount it where it is subject to wetting from sprinklers, hoses, etc. **Mount control panel where there is a minimum working space 30" wide and 6' high.**
10. The control panel must never be connected to a circuit that is not properly grounded. Never plug the unit into a receptacle that has a 2 pole to 3 pole grounding adapter attached. If there is any doubt, have a qualified electrician check for proper grounding. The control panel must be connected to an electric source equipped with a ground fault current interrupter (GFCI) circuit breaker or GFCI receptacle. A standard receptacle can be replaced with a GFCI receptacle. GFCI breakers and receptacles can be obtained from most stores that sell electrical supplies.
11. The wires from the filter system to the control panel if direct buried **MUST BE TYPE UF** rated for underground service. It must be buried a minimum of 2 feet below the final grade and must be protected by conduit where it exits the ground as shown on installation drawings. Conduit must extend a minimum of 1'-6" below ground where the wires rise from the ground to the control panel. These requirements are per the National Electric Code. Check with local authorities to see if they have more stringent requirements. Schedule 40 PVC is shown, note this is conduit not water pipe. However, if the conduit is subject to physical damage, you must use Schedule 80 PVC conduit and appropriate fittings.
12. Wire the solenoid valves as shown on the drawings.
13. Verify that all electrical systems are connected and secure.
14. Close cover on control panel and connect control panel to a ground fault current interrupter (GFCI) circuit.
15. Verify proper pump operation by observing pump while manually operating pump float switch. Pump must not be run unless immersed in water. Verify alarm system by manually operating alarm float switch. Pump and dispose of all clean water in the tank. Verify that 1'-2" of water remains inside the tank when pump stop float switch turns pump off. Verify operation of the floats by observing PLC input screen.
16. Install a 2-inch layer of gravel in the access boxes and complete back filling the site.
17. Install drip line 6 to 8 inches deep, but not to exceed 18" below ground. The drip line should not be stretched during installation or damage may occur.
18. Install the system header first: Typical layout will be Filter Unit, Zone Valve (if required) and pressure regulator at each individual Drip Zone. Then install the PVC schedule 40 supply lines. These should be buried at a depth of 12 to 18 inches, 4 to 12" below the depth of the WASTEFLOW® lines. If there is a risk of freezing, bury mainlines below the frost line. At all times avoid getting debris into the system. Flush main lines, test for leaks and leave them full of water. Larger diameter pipes left full of air in a trench that has not been compacted may "float". System must be installed per drip line layout drawings.
19. Open trenches for the sub-main manifold and flush line manifold. These trenches should be 8 to 10 inches deep. At the beginning of the drip line trench construct an earthen damp above drip line elevation and lay drip line over earthen damp to manifold. This will prevent water from draining from drip line.
20. Clean sub-main and flush line manifold trenches, moisten and compact the bottom of the trench. (If this is not done, the manifolds may "settle down" and slowly pull out the couplings). Assemble the submain manifold outside the trench if practical. Connect to main PVC lines and to the system header. Flush these lines. A high water velocity is required to carry away debris that may have entered the pipes before or during installation. Place the sub-main and flush manifolds into the trench.
21. Install drip lines on contour, not perpendicular or up and down, etc. to the slope. No two drip laterals in the same zone should have more than an 8 feet elevation difference, when using Goeflow Classic.

INSTALLATION INSTRUCTIONS

22. Maximum lateral length, for standard zones are as indicated in Table 1, consult Infiltrator Treatment Systems for alternative zones.
23. Minimum lateral spacing must be 2 feet, except for special design.
24. Lateral spacing of three feet or more should be used for slopes of 20% or greater.
25. Install air vent/vacuum breakers at the high end of each drip zone supply and return manifold. Air vents/vacuum breakers to be placed in protective enclosure to prevent an accumulation of substances that could prevent their proper operation and they must have a grade level access
26. The size of the installation, type of soil, slope, availability of labor and cost will determine the best installation method. During installation cover all open pipe ends including drip lines to avoid getting dirt or debris into the system. Leave enough length at the beginning and end of each drip line for connections. It may be more convenient to finish the last foot or so of the trench by hand. This gives more room for connections. Beware of bending the drip tubing too tight during installation. Do not bend tubing at the 24" radius loops or the pipe may kink, reducing the flow. Use 1/2" flexible PVC pipe and fittings to loop emitter tubing. The drip line will elongate at high temperatures, do not store in direct sunlight. To prevent stress due to contraction always leave tube snaked from side to side of trench (1' per 100') or when plowing leave slack at supply and return manifold. Connect drip lines to sub-main and flush manifolds. Flush again. Run the system before covering and check for leaks.
27. Install sSchedule 40 PVC for return flush line. Run return line back to the filter system. The electric solenoid valve that operates the flush line is part of the filter system. Install Schedule 40 PVC drip flush line and filter flush line back to the treatment plant as shown on the drawings.
28. To overcome the lack of depth to a restrictive horizon and/or seasonal water table a clean fill material of loamy sand, sandy loam or light loam may be used as fill. The fill material shall consist of a minimum of 70% sand particles equal to or greater than 0.25 mm. Clay content shall be 20% or less. Organic matter should be removed prior to placing fill material. If not the site must be plowed to prevent an organic sealing layer from forming. Fill material should be applied over the entire area in a shallow layer (3 inches) and then be tilled into the natural soil to prevent a textural interface from forming. When fill is used, the entire area must be covered with sod to prevent erosion or other erosion control measures taken.
29. Whenever possible, spend time with your customer. Review operation instructions. Be sure that the customer has a manual to keep with them, this may avoid an unnecessary return visit.

Infiltrator Treatment Systems FILTER SERVICE POLICY

INITIAL POLICY:

The manufacturer or the distributor through the dealer shall furnish a two-year initial service policy to the user. *This policy is included in the original purchase price* and shall provide the following:

1. **An inspection/service call every six months**, which includes inspection, adjustment, and servicing of the mechanical and electrical component parts as necessary to ensure proper function.
2. If any improper operation is observed which cannot be corrected at that time, the user shall be notified immediately in writing of the conditions and the estimated date of correction.

CONTINUING SERVICE POLICY:

An annually renewable service policy affording the same coverage as the Initial Service Policy is available. Consult your dealer for pricing information.

PARTS:

Replacement parts or components may be obtained from your local distributor.

COMPLAINTS:

In order for Infiltrator Treatment Systems to properly address any complaints we require that you put in writing the date and nature of the complaint as detailed as possible.

Send to: Infiltrator Water Technologies
9125 Comar Drive
Walker, LA 70785

**CAPACITY OF ROUND TANKS
Per Foot of Depth**

Diameter	Gallons	Area Sq. Ft.	Diameter	Gallons	Area Sq. Ft.
2'	23.50	3.14	6'	211.51	28.27
2' 6"	36.72	4.909	6' 6"	248.23	35.18
3'	52.88	7.069	7'	287.88	38.48
3' 6"	71.97	9.621	7' 6"	330.48	44.18
4'	94.00	12.566	8'	376.01	50.27
4' 6"	118.97	15.90	8' 6"	424.51	56.75

**CAPACITY OF SQUARE OR RECTANGULAR TANKS
Per Foot of Depth**

Length & Width	Gallons	Area Sq. Ft.	Length & Width	Gallons	Area Sq. Ft.
4' x 4'	119.68	16	9' x 9'	605.88	81
5' x 5'	187.00	25	10' x 10'	748.08	100
6' x 6'	269.28	36	11' x 11'	905.08	121
7' x 7'	366.52	49	12' x 12'	1077.12	144
8' x 8'	478.72	64	14' x 14'	1466.08	196

Volume in gallons per foot of a Square or Rectangular Tank = Length x Width x 7.48 gallons per cubic foot.

PERCOLATION – HYDRAULIC CHART

Soil Type	Percolation Rate Min./In.	Hydraulic Conductivity In./Hour	Hydraulic Loading Gal./Day/Ft.2	Area Required Ft.2/100Gal/Day
Coarse Sand	<5	>2	2.0	52
Fine Sand	5 – 10	1.5 – 2	1.6	65
Sandy Loam	10 – 20	1.0 – 1.5	1.3	80
Loam	20 – 30	0.75 – 1.0	0.9	115
Clay Loam	30 – 45	0.5 – 0.75	0.6	175
Silty Clay Loam	45 – 60	0.3 – 0.5	0.4	260
Clay, Non-Swell	60 – 90	0.2 – 0.3	0.2	520
Clay, Swell	90 – 120	0.1 – 0.2	0.1	1040
Clay, Poor	>120	>0.1	0.075	1380

The above table is provided as a guide only, you must follow all local, county and state code requirements.

ELECTRICAL COMPONENT INFORMATION & DRAWINGS

Setting the PLC

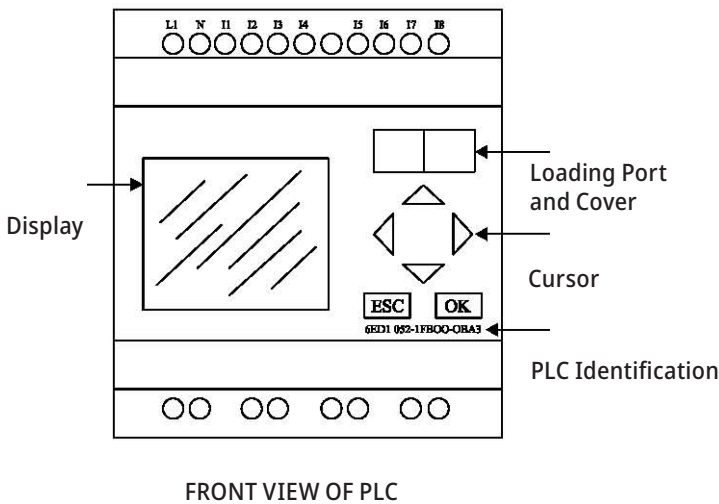

point for all programming.

Locating the clock screen:

Use the **"DOWN"** key to scroll until the clock screen is shown.

To enter into program mode press **"ESC"** once. (See Chart 1) Arrow down to desired selection and press **"OK"**.

- To set clock, arrow down to **"SET"** and press **"OK"**. **"CLOCK"** will appear. Press **"OK"**. **"SET CLOCK"** will then appear. Press **"OK"** again. Use **"LEFT"** and **"RIGHT"** arrow keys to maneuver around and the **"UP"** and **"DOWN"** keys to change setting. Once complete press **"OK"**. To get to parameter screen press **"ESC"**. To get to main screen (clock showing) press **"ESC"** again.
- To set parameters, arrow down to **"SET PARAMETERS"** and press **"OK"**. Use **"UP"** and **"DOWN"** arrow keys to scroll through blocks. Once desired block is found press **"OK"**. Use **"LEFT"** and **"RIGHT"** arrow keys to maneuver around and the **"UP"** and **"DOWN"** keys to change the parameter. Once parameter is set press **"OK"**. Now you may continue to scroll the blocks. Once scrolling is complete press **"ESC"**. To return to the main screen press **"ESC"** again.

Upon power up the clock screen *may not* be displayed. The clock screen is considered the **"main"** screen and will be the starting

Chart 1 – Earlier versions of the PLC required different key combinations to enter into program mode, with the **clock showing, press the following:**

PLC Identification	
OBA00	Press "OK" and "LEFT" and "RIGHT" arrow keys (at the same time)
OBA1 – OBA2	Press "ESC" and "OK" keys (at the same time)
OBA3 – OBA5	Press "ESC" key (once)

- To view inputs, at the main screen (clock showing) press the **"RIGHT"** arrow key. To return to main screen press **"LEFT"** arrow key.
- To view outputs, at the main screen (clock showing) press the **"RIGHT"** arrow key twice. To return to main screen press **"LEFT"** arrow key twice.
- Earlier versions of the PLC had the inputs, outputs and clock on the main screen upon power up.

Notes:

PLC Parameters

Block	Description	Factory Setting	PLC Nomenclature
B01	T = Run time TL = Off time	12 minutes 2 hours	12:00 m 02:00 h
B02	Off time during override period	1 hour	01:00 h
B03	Filter flush time after pump turns on	1 minute	01:00 m
B04	Filter drain time after pump turns off	2 minutes	02:00 m
B05	Field flush time normal operation	2 minutes	02:00 m
B06	Field drain time afer pump turns off	2 minutes	02:00 m
B07	Number of fields	4	4
B08	Number of cycles until 1st field flush	84	84
B09	Field flush time when field flush switch is pressed	1 minute	01:00 m

Notes:

Minute settings are in minutes and seconds.

For example: 02:00 m is 2 minutes, 02:10 m is 2 minutes and 10 seconds. Hour settings are in hours and minutes.

For example: 02:00 h is 2 hours and no minutes, 02:10 h is 2 hours and 10 minutes, and 00:12 h is 12 minutes.

In addition to the settings above, various other parameters can be viewed as follows:

- Pump run time hours
- Pump start counts
- Level override counts
- High level counts
- Switch to hand counts

HEADWORKS FILTER SYSTEM WWSFA

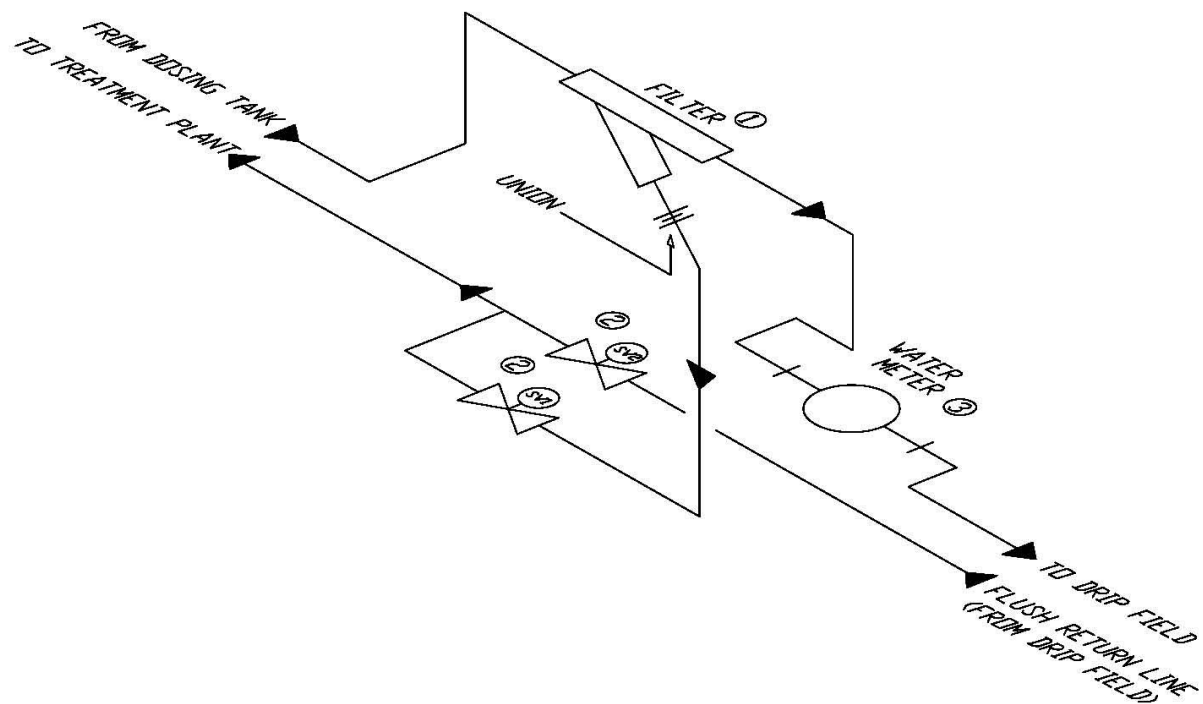

NOTE:

- SV1 – FILTER FLUSH VALVE
- SV2 – FIELD FLUSH VALVE

FLOAT SELECTION CHART

<u>NUMBER OF FLOATS</u>	<u>FLOAT</u>				
	FS1	FS2	FS3	FS4	FS5
5 FLOAT SYSTEM	WA	S	S	S	S(N.C.)
4 FLOAT SYSTEM	WA	S	S	S	—
3 FLOAT SYSTEM	WA	—	WA	S	—
2 FLOAT SYSTEM	WA	—	—	WA	—

WA = NORMALLY OPEN WIDE ANGLE
HIGH OR LOW CURRENT RATING

S = NORMALLY OPEN STANDARD NON-WIDE ANGLE
HIGH OR LOW CURRENT RATING

N.C. = NORMALLY CLOSED FLOAT

FS1 – WIDE ANGLE FLOAT THAT, WHEN UP, WILL ALLOW THE PUMP TO START AND WHEN DOWN, WILL STOP THE PUMP. IT KEEPS THE PUMP FROM RUNNING DRY.

FS2 – WHEN DOWN, RESETS THE OVERRIDE FUNCTION.

FS3 – WHEN UP, STARTS A PUMP CYCLE AND OPERATES ON A SHORT PUMP CYCLE UNTIL FS2 DROPS.

FS4 – WHEN UP, ALARMS HIGH LEVEL. DOES NOT START PUMP.

FS5 – WHEN DOWN, ALARMS LOW LEVEL. DOES NOT STOP PUMP.

CONNECTION OF FLOATS

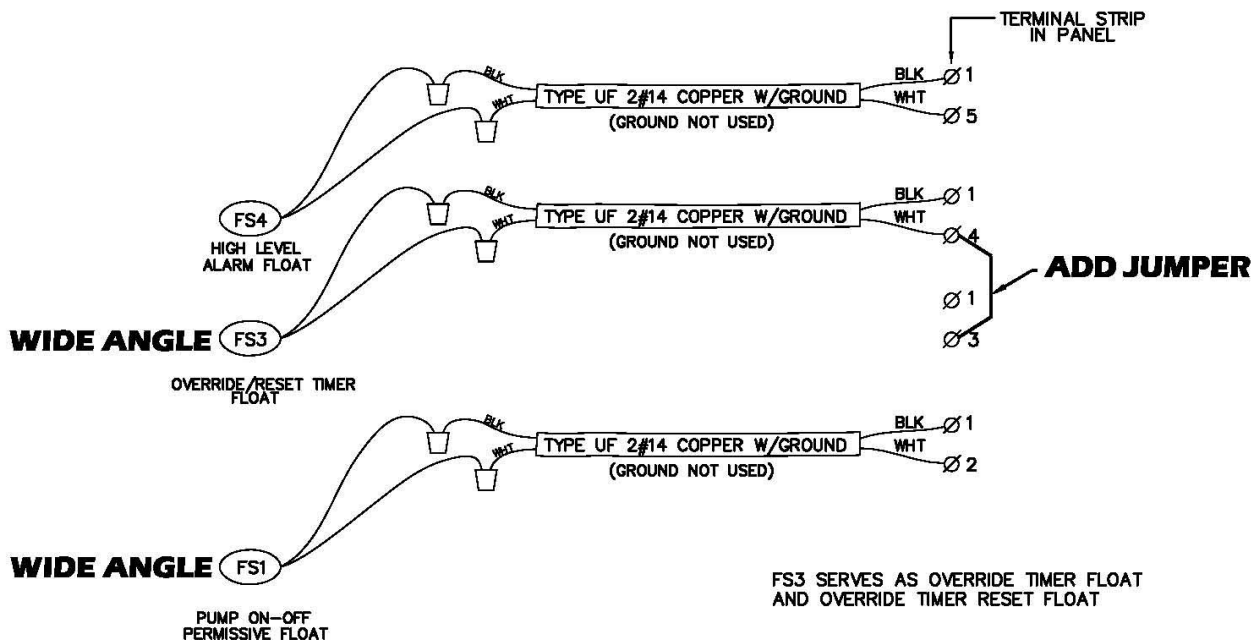

3 FLOAT SYSTEM

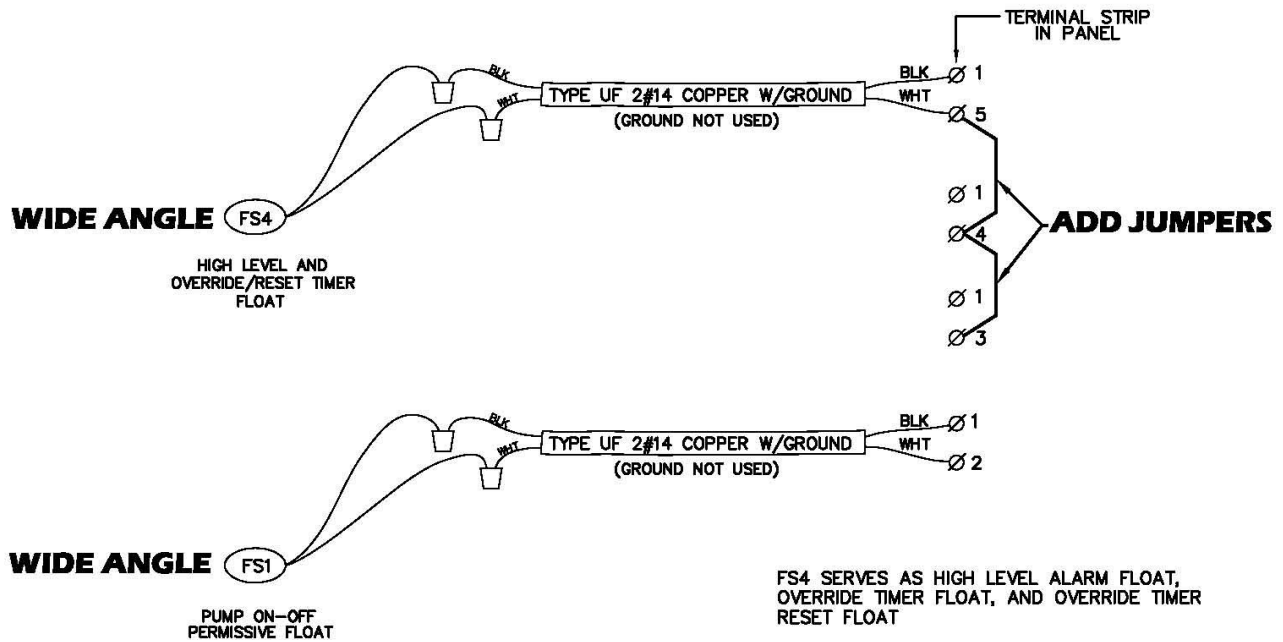

2 FLOAT SYSTEM

CONTROL DIAGRAM - SINGLE CIRCUIT 120VAC

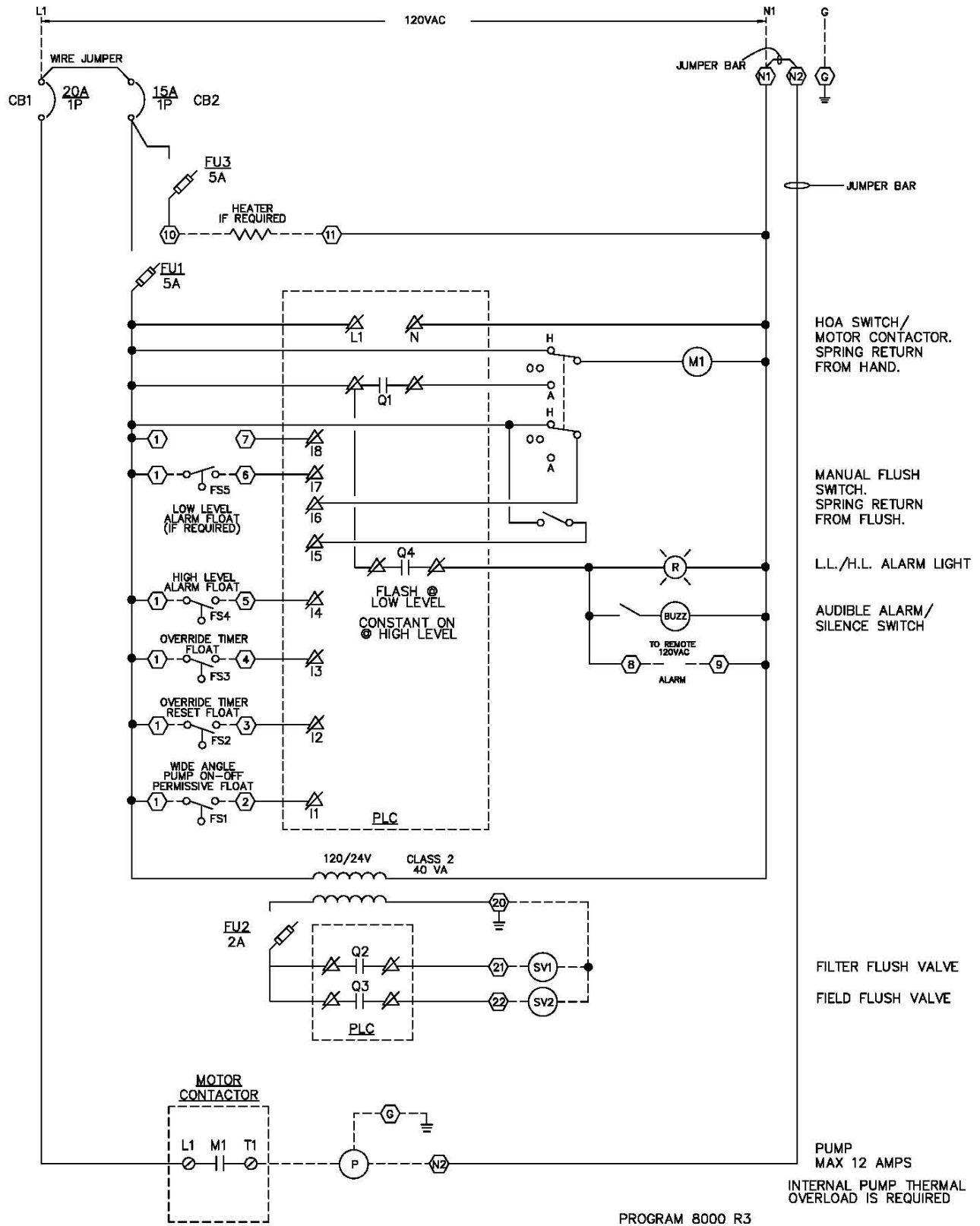

CONTROL DIAGRAM - DUAL CIRCUIT 120VAC

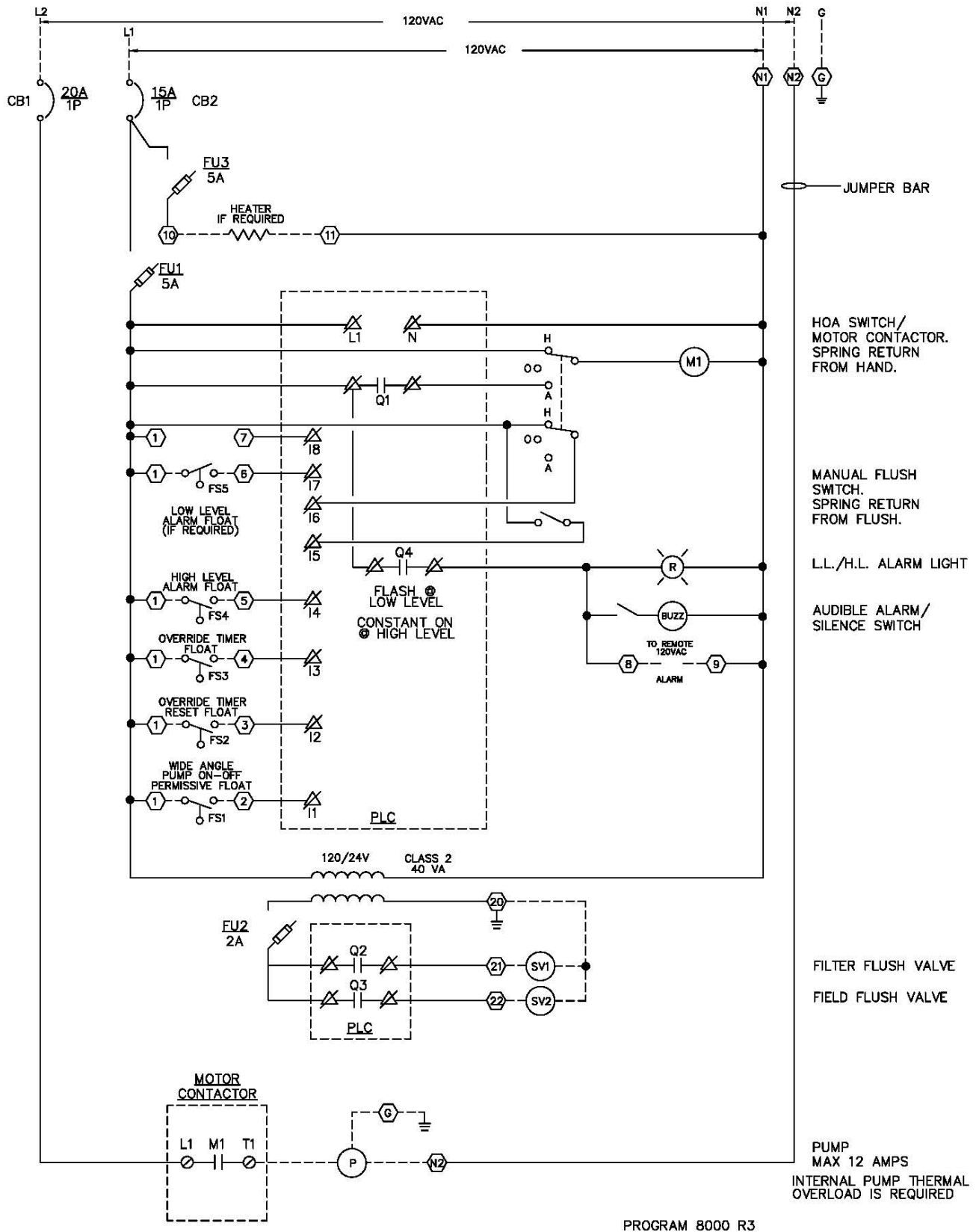

CONTROL DIAGRAM – SINGLE CIRCUIT 230VAC

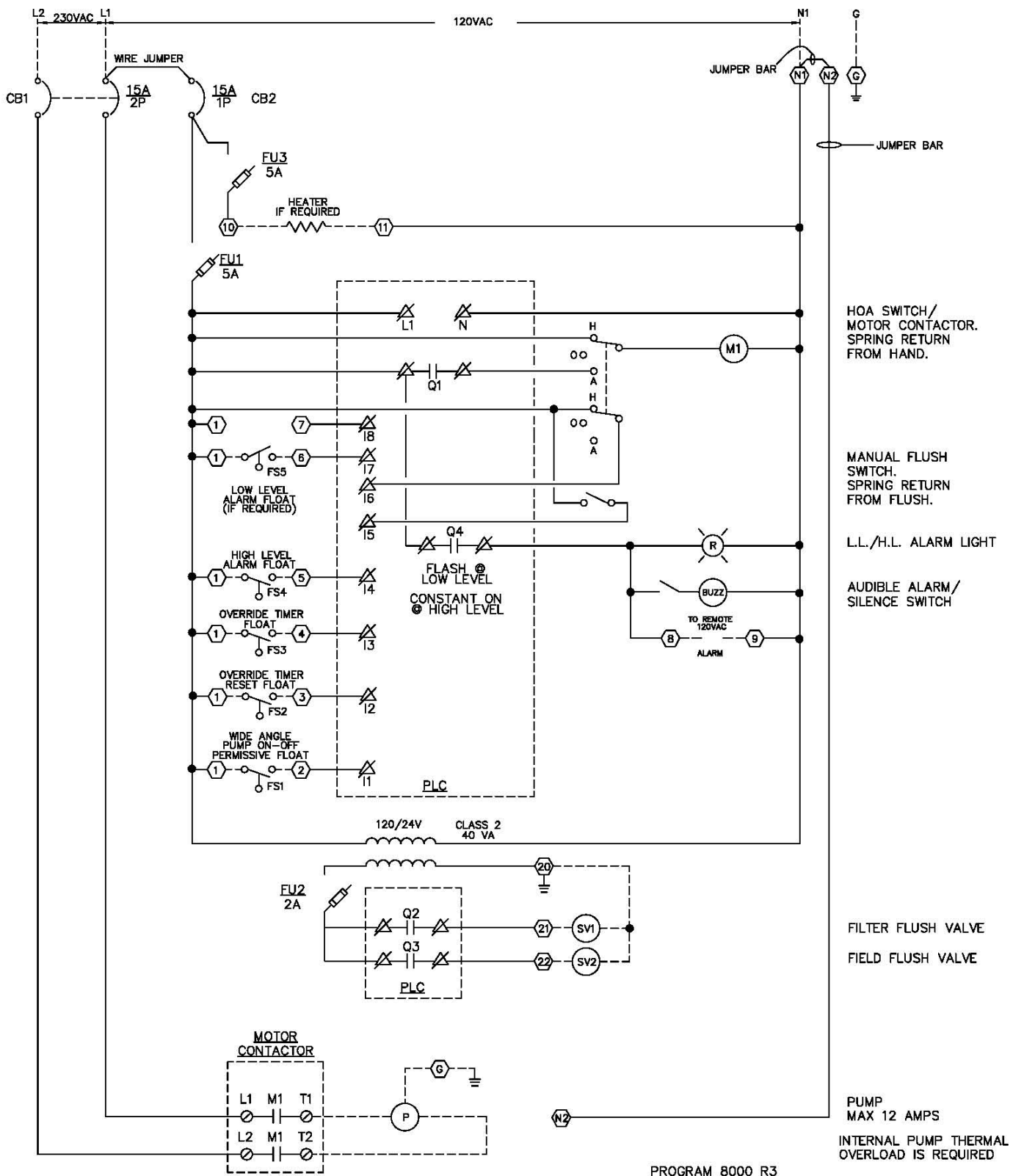

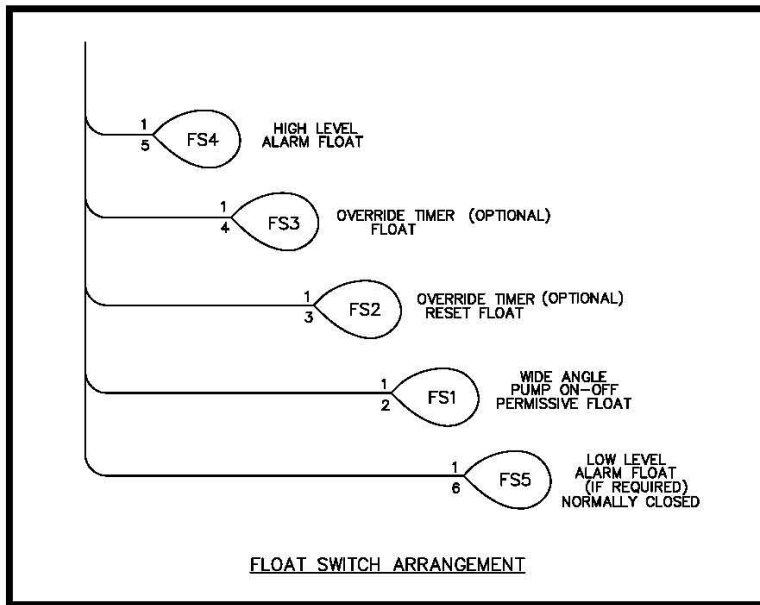
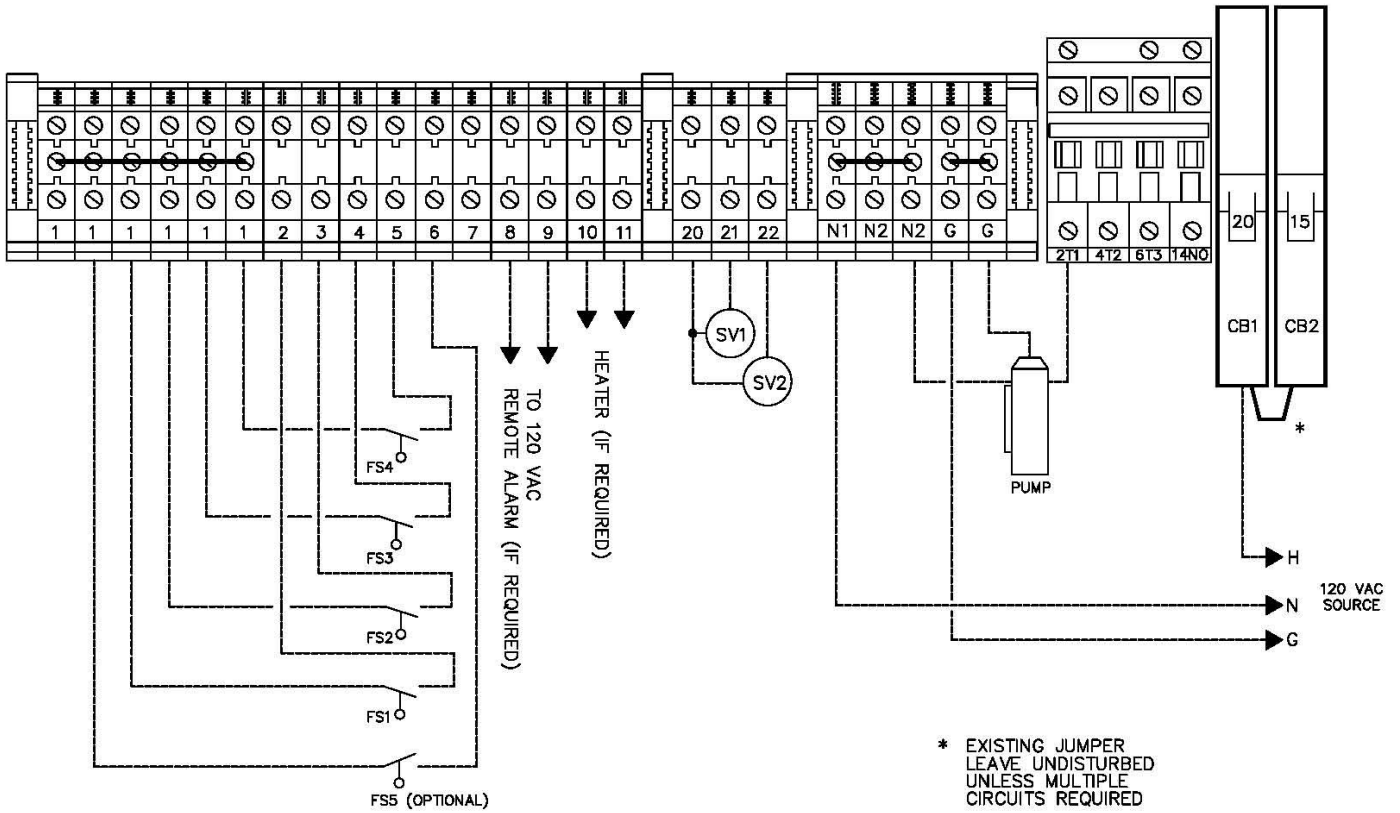

HEADWORKS FILTER SYSTEM 8230

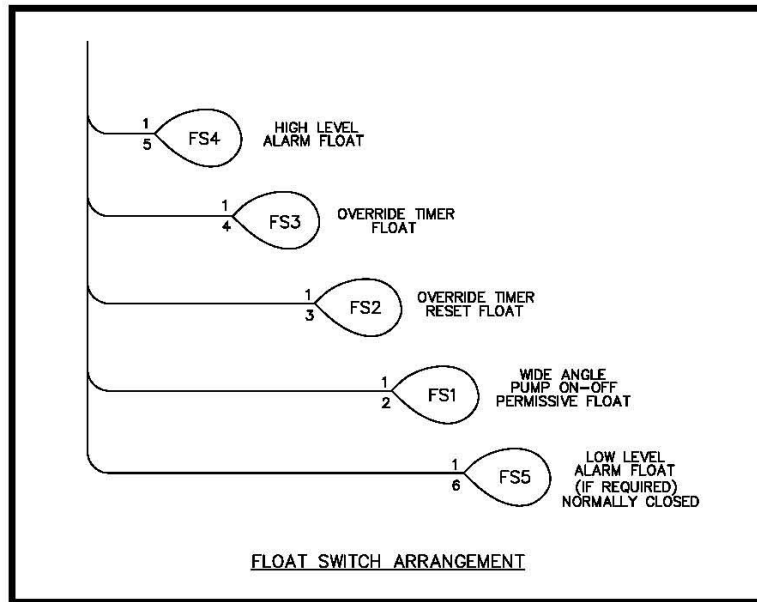
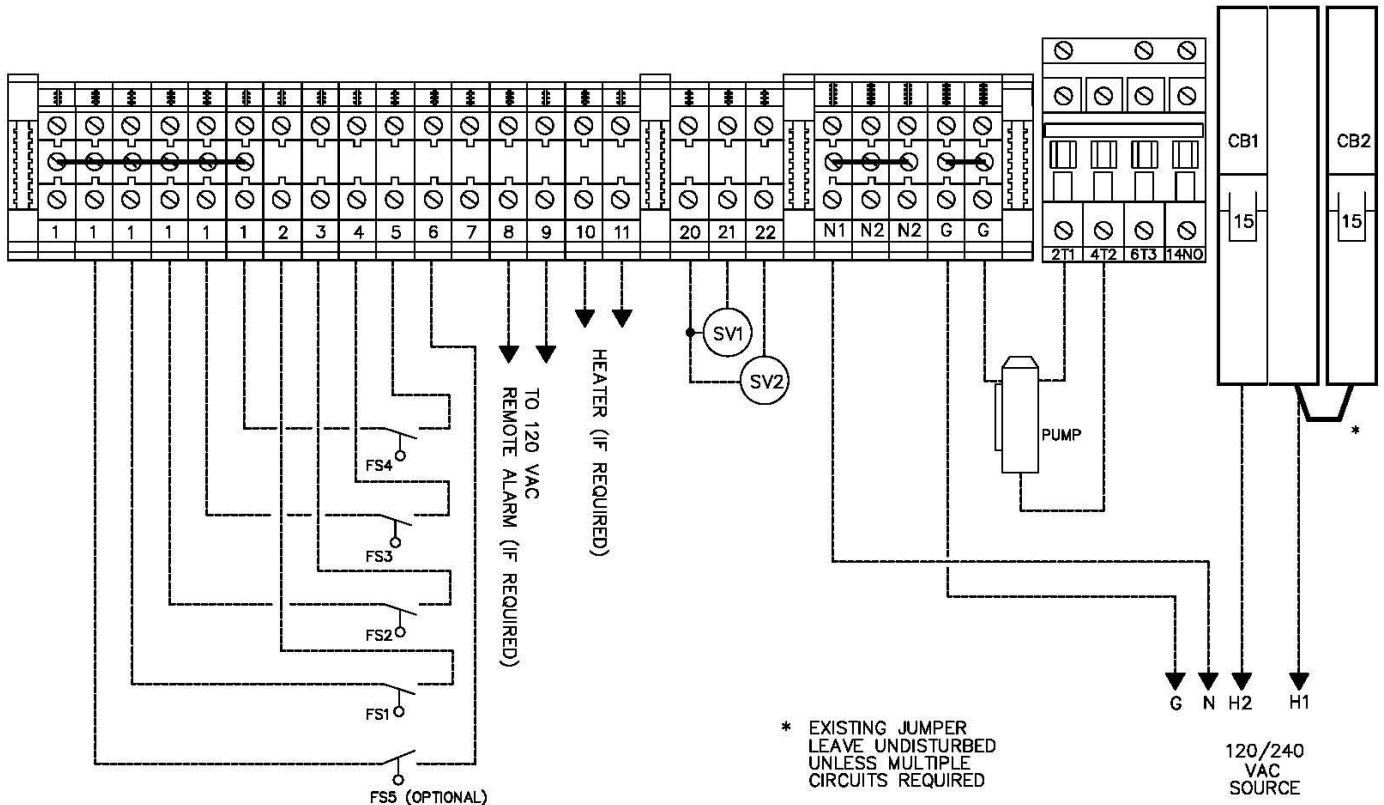

HEADWORKS FILTER SYSTEM 8115

* USE SCH. 80 IF SUBJECT TO ABUSE

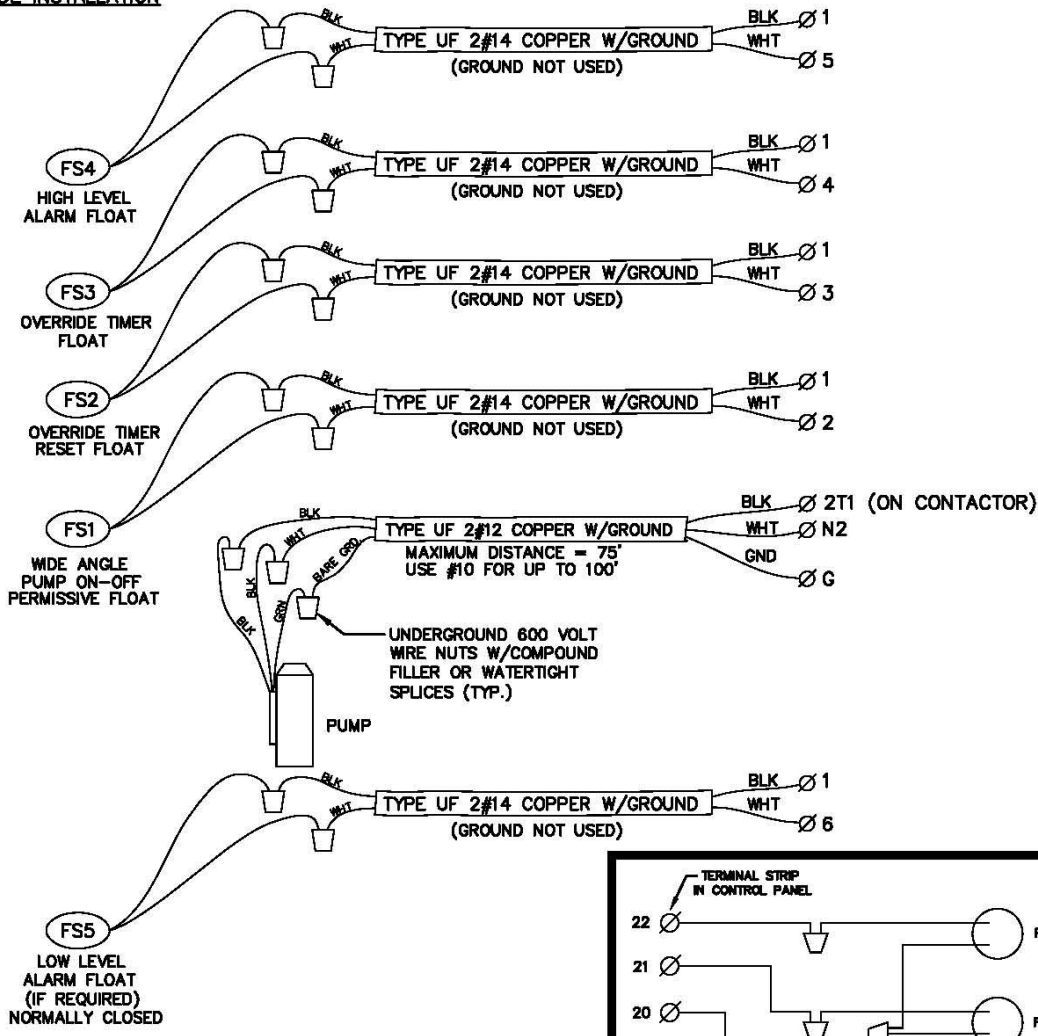
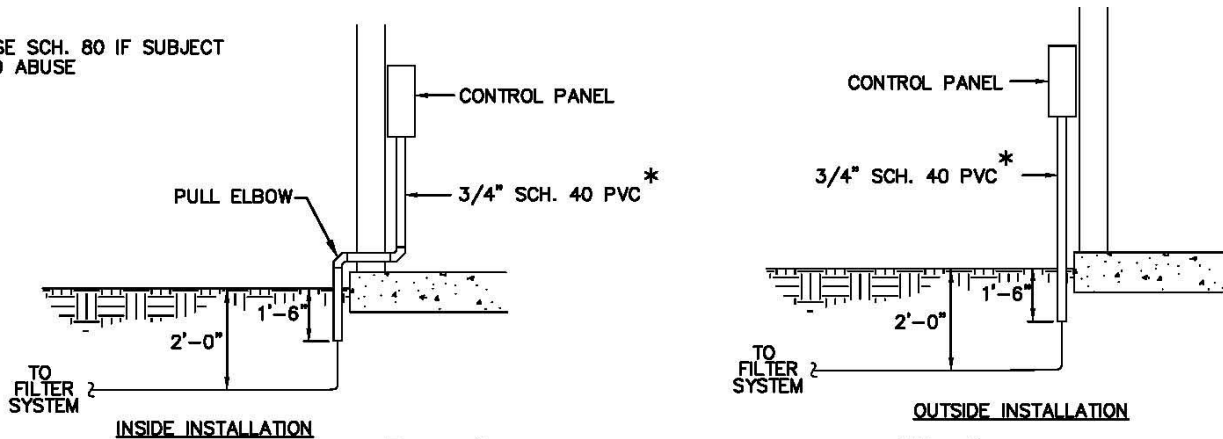

CONNECTIONS OF UNDERGROUND WIRE TO MOTOR AND FLOAT SWITCHES

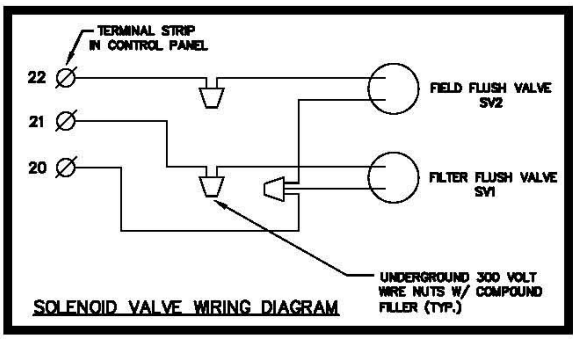

SOLENOID VALVE WIRING DIAGRAM

HEADWORKS FILTER SYSTEM 8230 – ELECTRICAL INSTALLATION

* USE SCH. 80 IF SUBJECT TO ABUSE

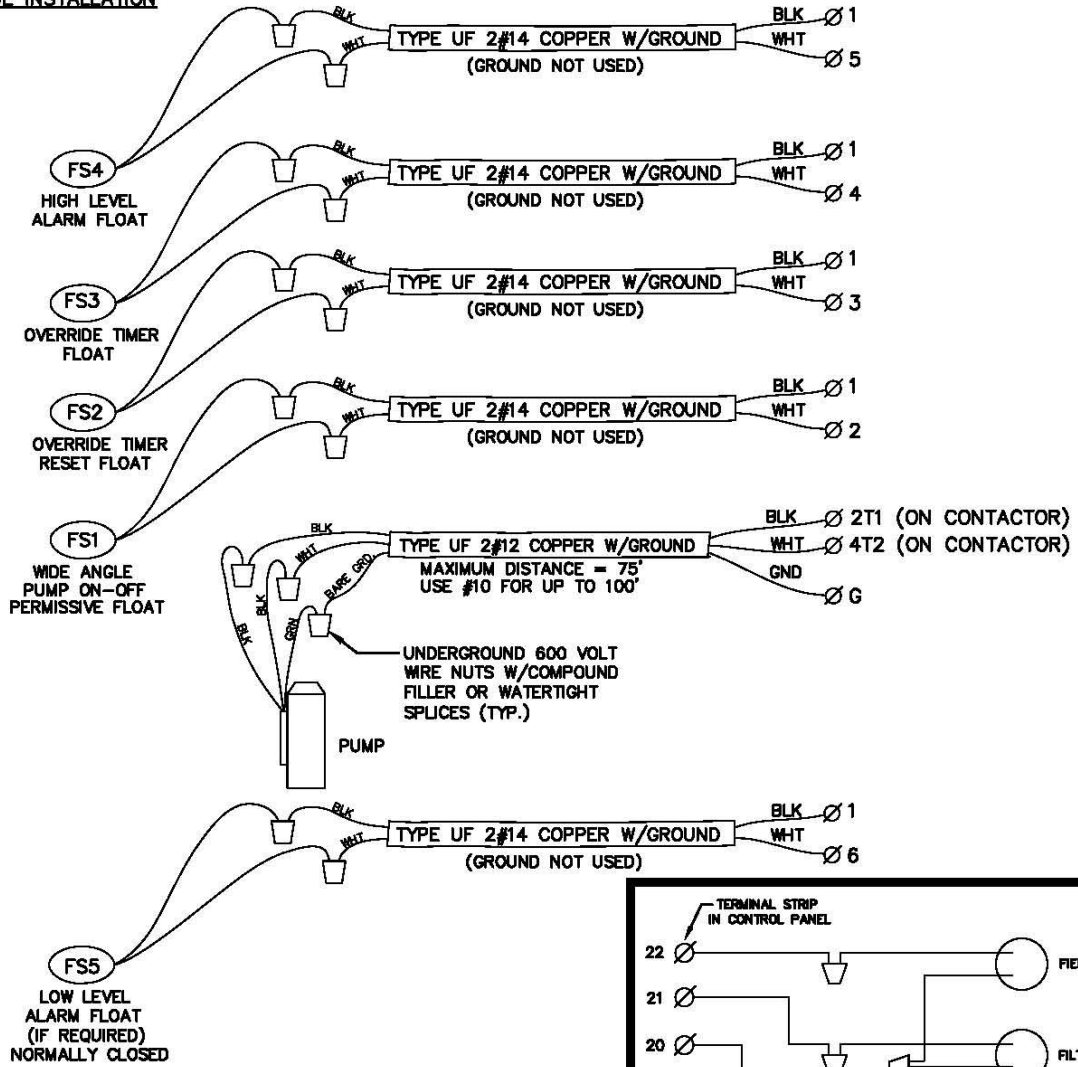
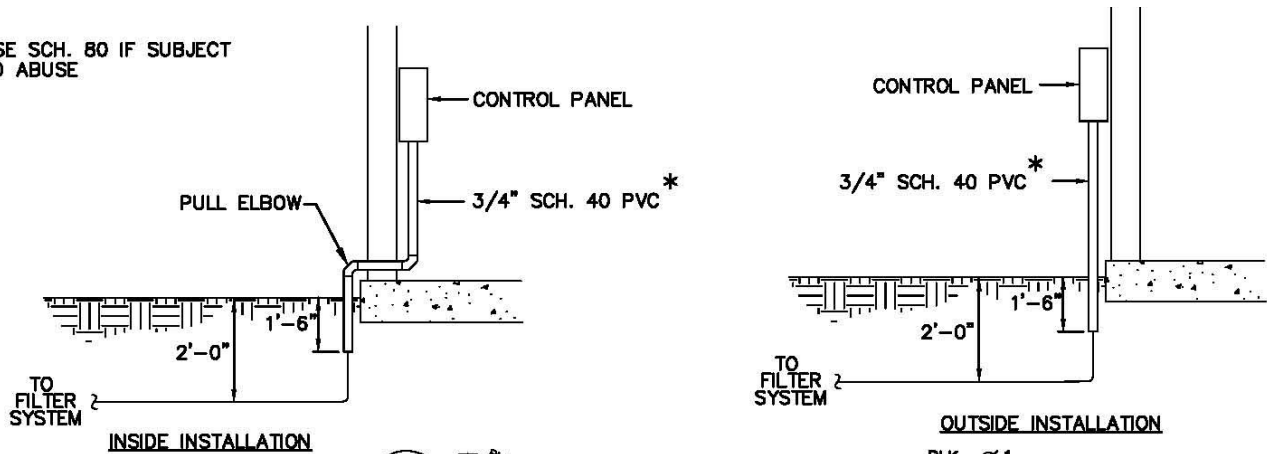

CONNECTIONS OF UNDERGROUND WIRE TO MOTOR AND FLOAT SWITCHES

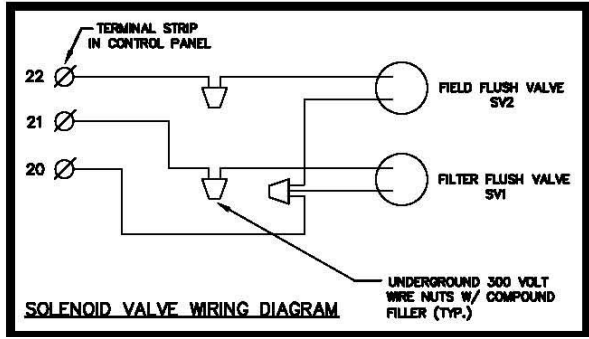

SOLENOID VALVE WIRING DIAGRAM

HEADWORKS FILTER SYSTEM 8115/8230

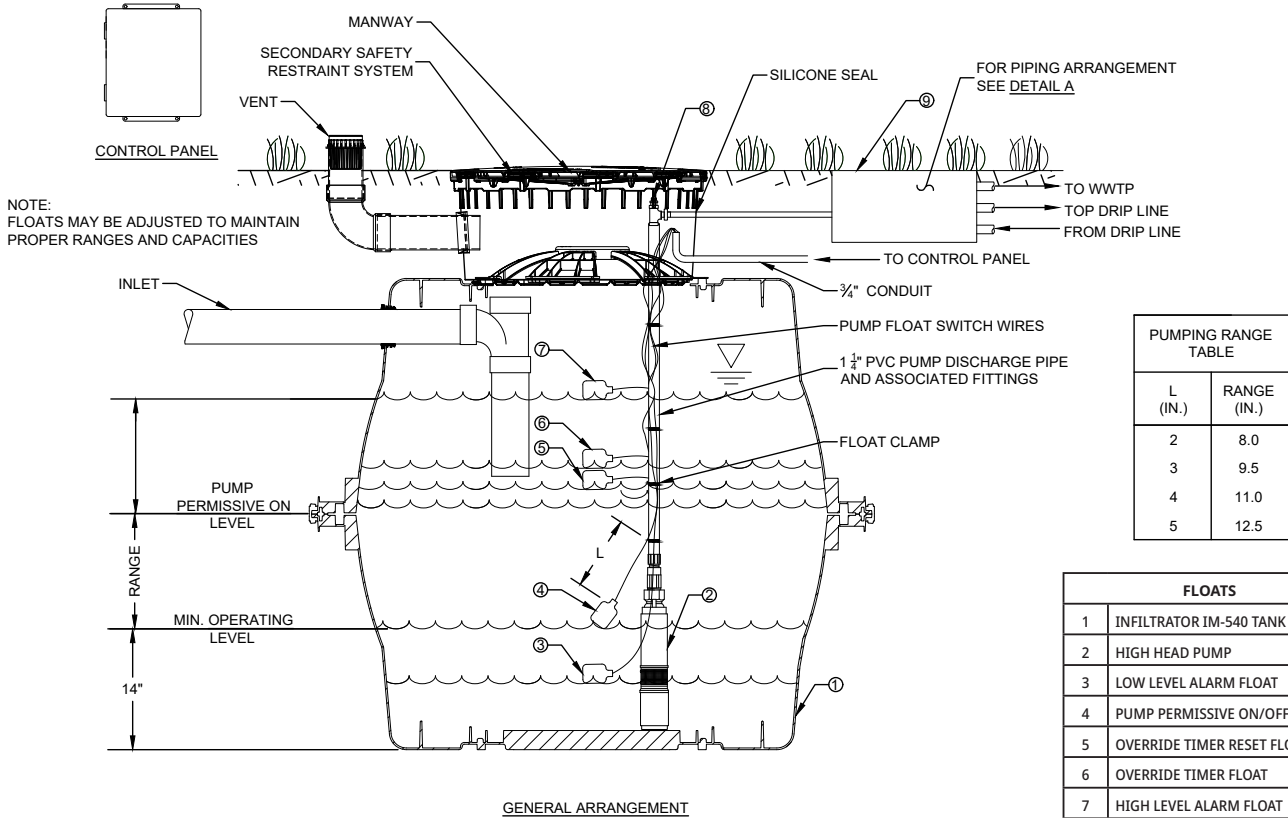

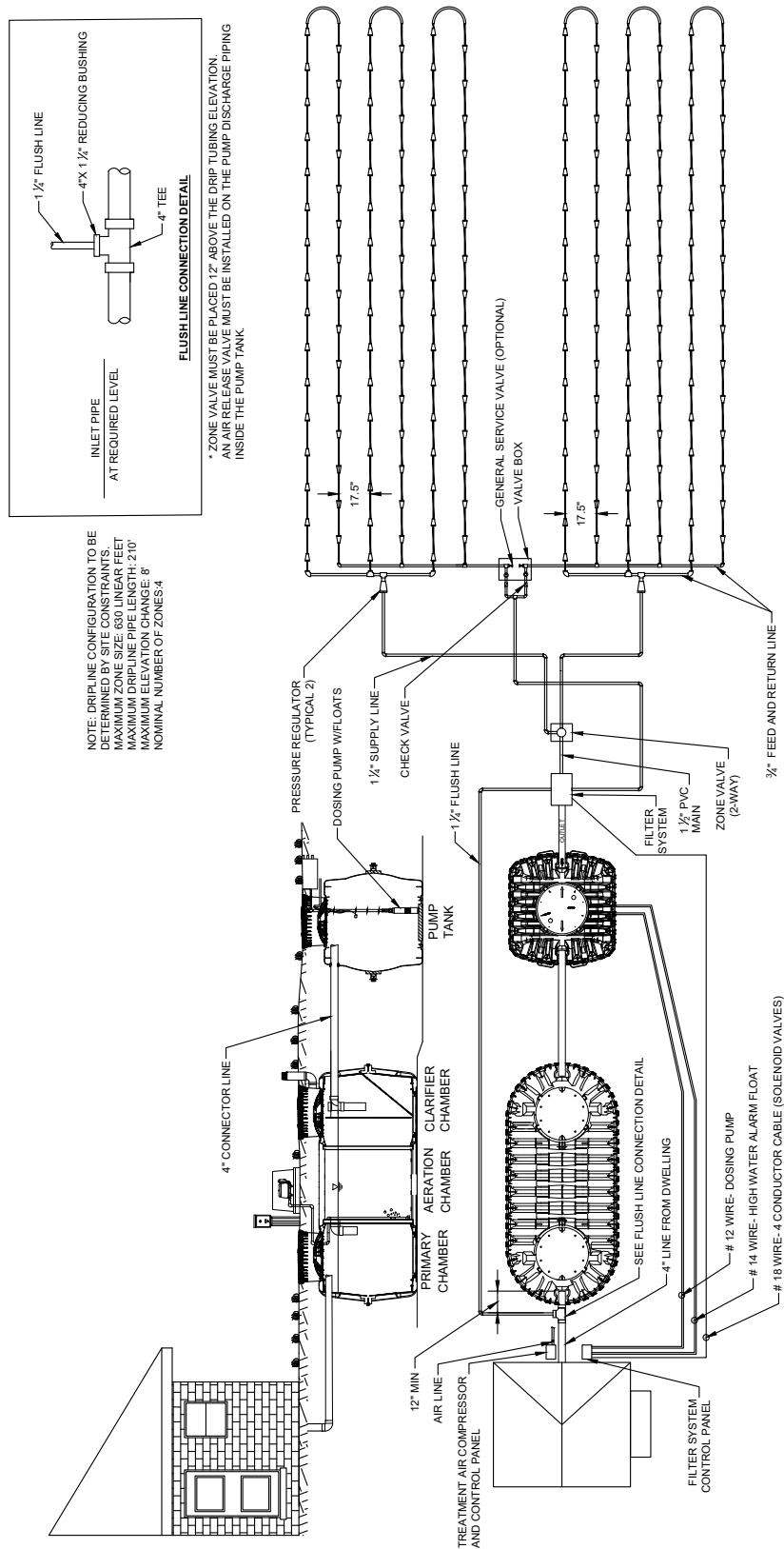

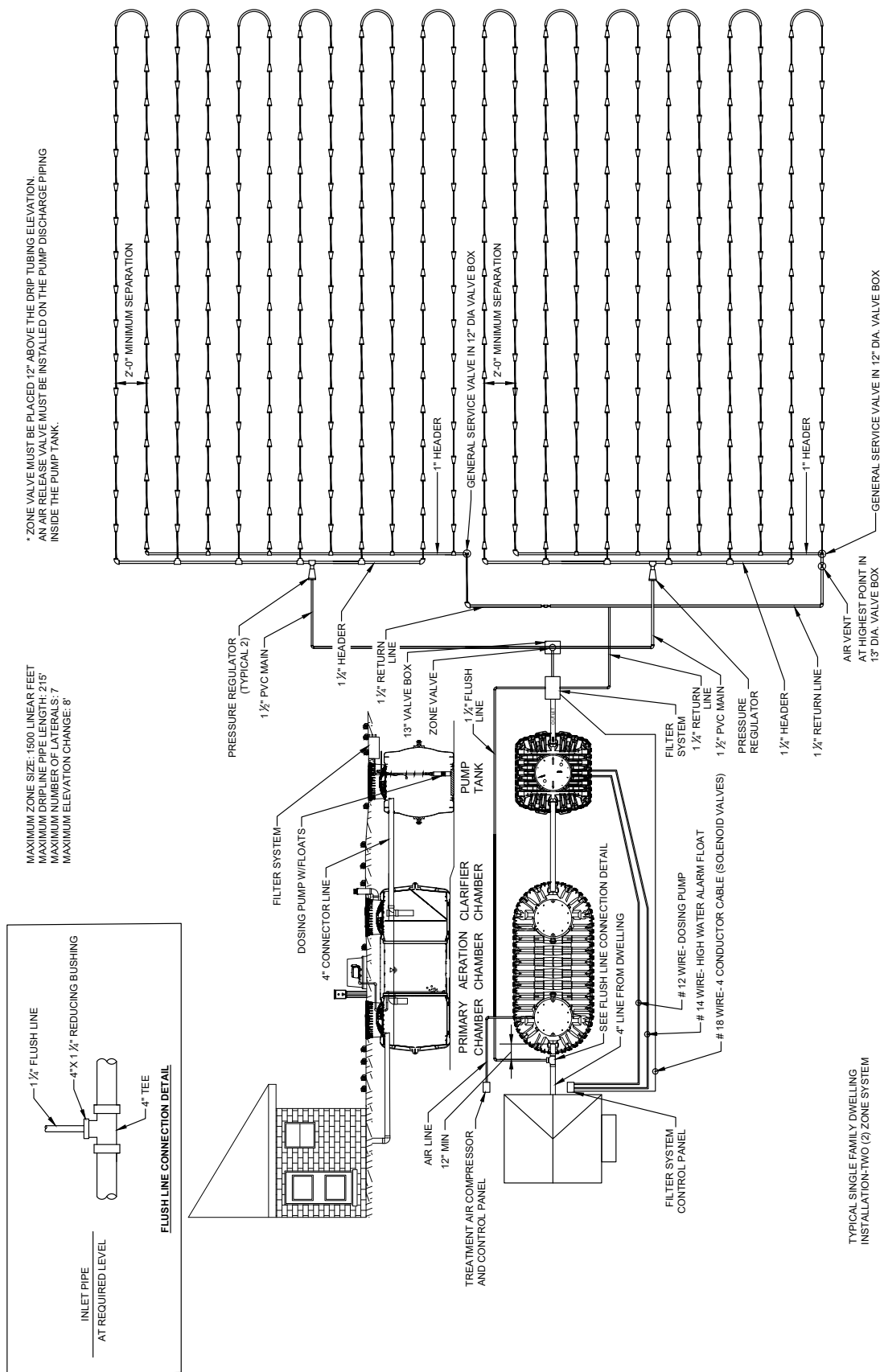

* ZONE VALVE MUST BE PLACED 12" ABOVE THE DRIP TUBING ELEVATION. A RELEASE VALVE MUST BE INSTALLED ON THE PUMP DISCHARGE PIPING INSIDE THE PUMP TANK.

MAXIMUM ZONE SIZE: 1500 LINEAR FEET
 MAXIMUM LENGTH: 215'
 MAXIMUM NUMBER OF LATERALS: 7
 MAXIMUM ELEVATION CHANGE: 6

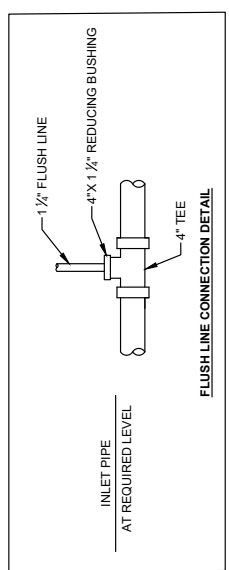

TYPICAL SINGLE FAMILY DWELLING
 INSTALLATION-TWO (2) ZONE SYSTEM

AIR/VACUUM RELIEF

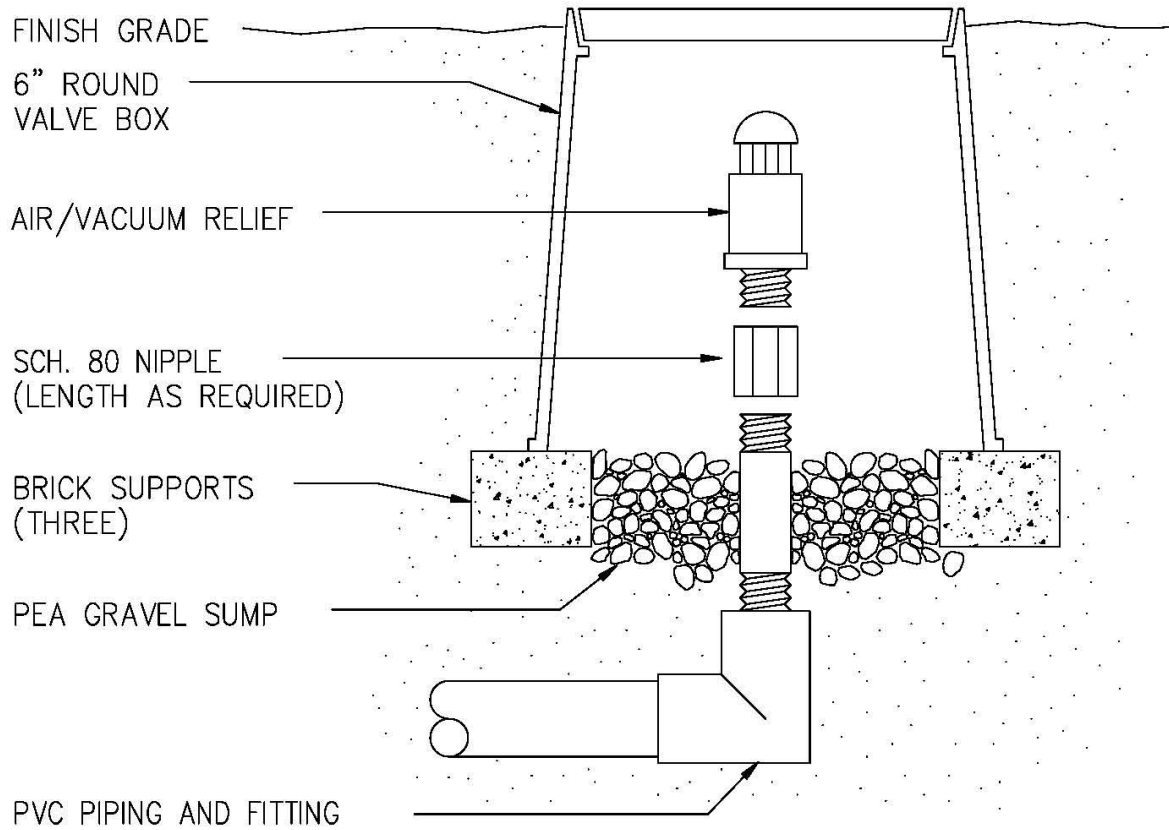

1" AIR/VACUUM RELIEF PLUMBED TO PVC ELL

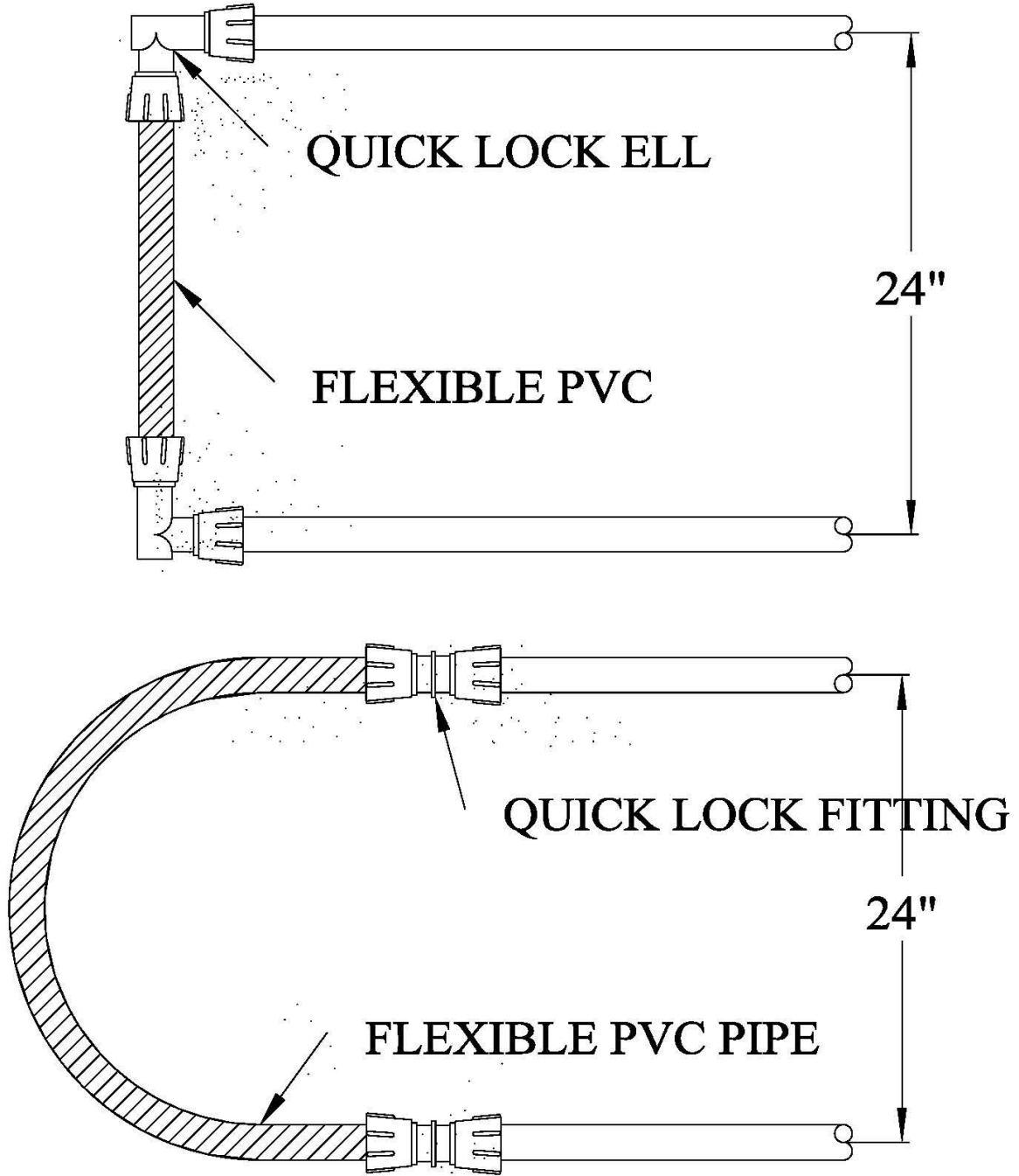

TYPICAL DRIPLINE CONNECTION IN TURN OR LOOP

TYPICAL DRIPLINE CONNECTION

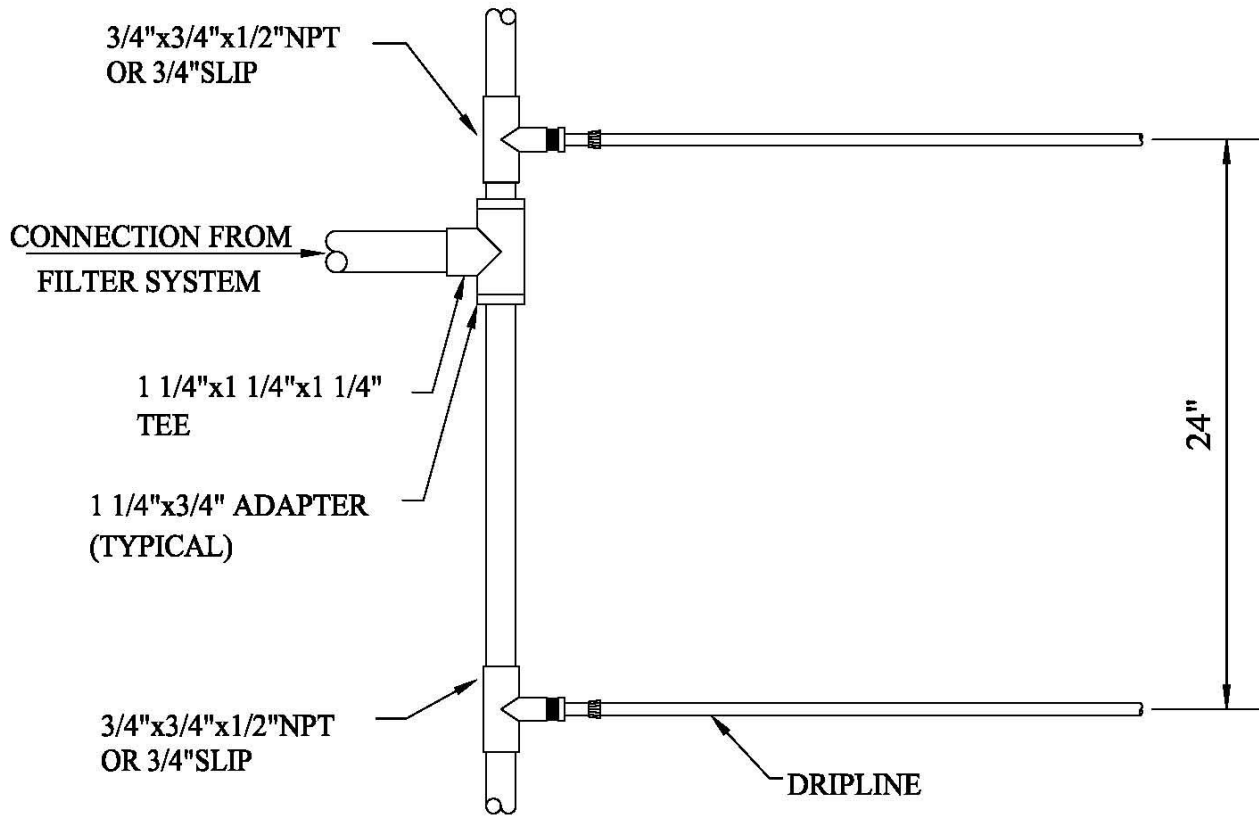
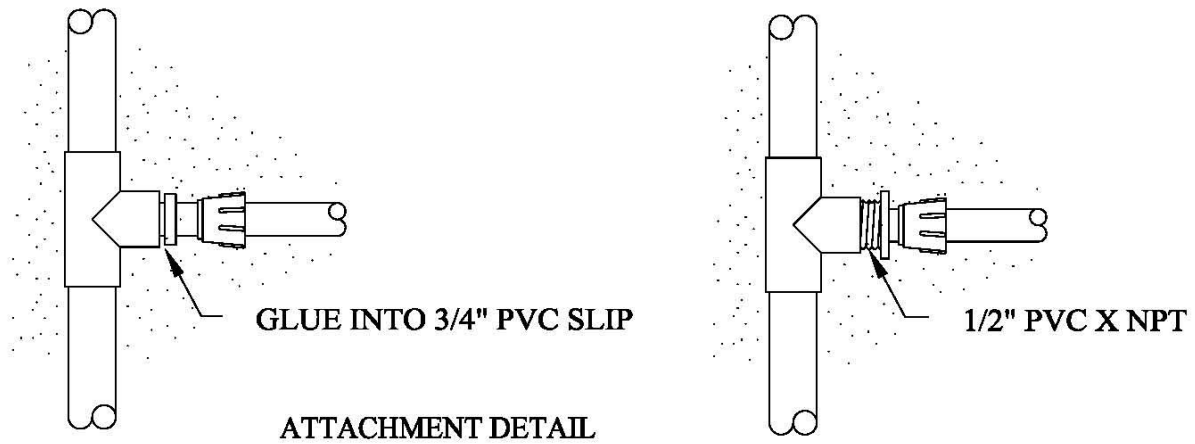

TYPICAL DRIPLINE CONNECTION

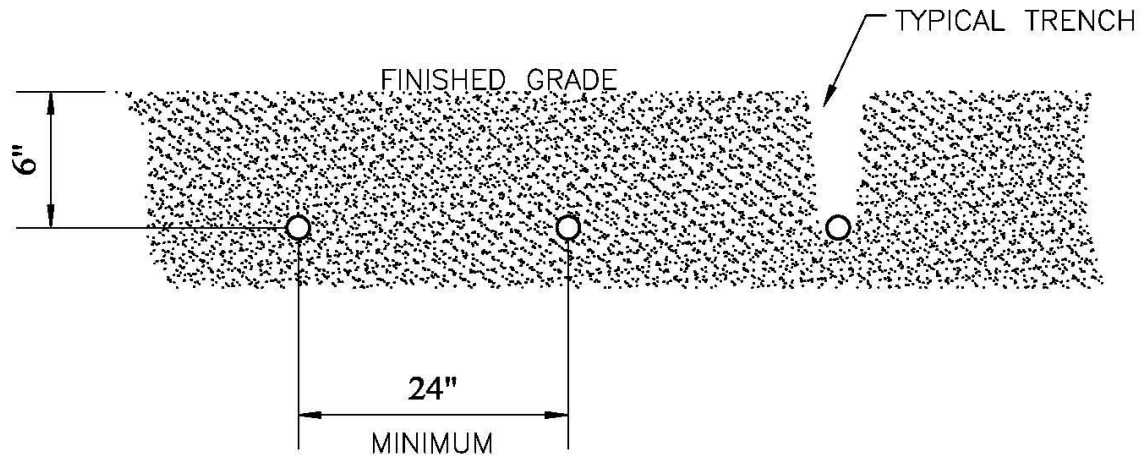

TYPICAL DRIPLINE INSTALLATION DETAIL

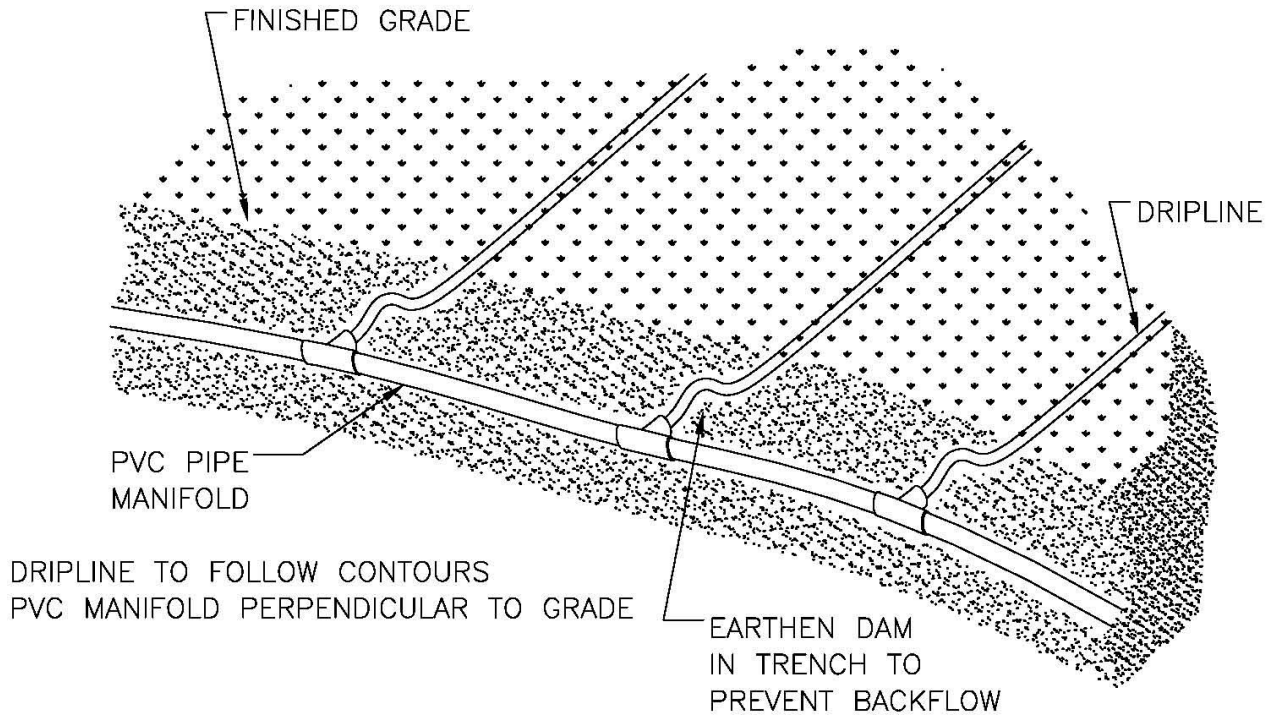

TYPICAL DRIPLINE INSTALLATION DETAIL

WARRANTY

Infiltrator TREATMENT SYSTEMS, LLC (“Infiltrator”) Infiltrator TWO (2) YEAR ECOPOD® SERIES MATERIALS AND WORKMANSHIP LIMITED WARRANTY

- (a) This limited warranty is extended to the end user of a Infiltrator ECOPOD® Series Advanced Wastewater Treatment Product (the “ECOPOD® Product”). An ECOPOD® Product manufactured by Infiltrator, when installed and operated in accordance with Infiltrator’s installation instructions and local regulation by a licensed installer, is warranted to you: (i) against defective materials and workmanship for two (2) years after installation. Infiltrator will, at its option, (i) repair the defective product or (ii) replace the defective materials. This Warranty does not cover any damage caused by flooding, abuse, unauthorized disassembly, improper wiring or overload protection. This Warrant does not cover any of the house wiring, plumbing, drainage or disposal systems.
- (b) In order to exercise your warranty rights, you must notify Infiltrator in writing at its corporate headquarters in Walker, Louisiana within fifteen (15) days of the alleged defect. Infiltrator reserves the right to inspect the item to confirm that it is defective.
- (c) YOUR EXCLUSIVE REMEDY WITH RESPECT TO ANY AND ALL LOSSES OR DAMAGES RESULTING FROM ANY CAUSE WHATSOEVER SHALL BE SPECIFIED IN SUBPARAGRAPH (a) ABOVE. Infiltrator SHALL IN NO EVENT BE LIABLE FOR ANY CONSEQUENTIAL OR INCIDENTAL DAMAGES OF ANY KIND, HOWEVER OCCASIONED, WHETHER BY NEGLIGENCE OR OTHERWISE. SOME STATES DO NOT ALLOW THE EXCLUSION OR LIMITATION OF INCIDENTAL OR CONSEQUENTIAL DAMAGES, SO THIS LIMITATION OR EXCLUSION MAY NOT APPLY TO YOU. THIS WARRANTY GIVES YOU SPECIFIC LEGAL RIGHTS AND YOU MAY ALSO HAVE OTHER RIGHTS WHICH VARY FROM STATE TO STATE.
- (d) THIS LIMITED WARRANTY IS THE EXCLUSIVE WARRANTY GIVEN BY Infiltrator AND SUPERSEDES ANY PRIOR, CONTRARY, ADDITIONAL, OR SUBSEQUENT REPRESENTATIONS, WHETHER ORAL OR WRITTEN. Infiltrator DISCLAIMS AND EXCLUDES TO THE GREATEST EXTENT ALLOWED BY LAW ALL OTHER WARRANTIES, WHETHER EXPRESS OR IMPLIED, OR STATUTORY, INCLUDING ANY WARRANTY OF MERCHANTABILITY, FITNESS FOR A PARTICULAR PURPOSE AND ANY IMPLIED WARRANTIES OTHERWISE ARISING FROM COURSE OF DEALING, COURSE OF PERFORMANCE, OR USAGE OF TRADE. NO PERSON (INCLUDING ANY EMPLOYEE, AGENT, DEALER, OR REPRESENTATIVE) IS AUTHORIZED TO MAKE ANY REPRESENTATION OR WARRANTY CONCERNING THIS PRODUCT, EXCEPT TO REFER YOU TO THIS LIMITED WARRANTY. EXCEPT AS EXPRESSLY SET FORTH HEREIN, THIS WARRANTY IS NOT A WARRANTY OF FUTURE PERFORMANCE, BUT ONLY A WARRANTY TO REPAIR OR REPLACE DEFECTIVE COMPONENTS.
- (e) YOU MAY ASSIGN THIS LIMITED WARRANTY TO A SUBSEQUENT PURCHASER OF YOUR HOME.
- (f) NO REPRESENTATIVE OF Infiltrator HAS THE AUTHORITY TO CHANGE THIS LIMITED WARRANTY IN ANY MANNER WHATSOEVER, OR TO EXTEND THIS LIMITED WARRANTY BEYOND THE STATED TWO (2) YEAR TERM.
- (g) NO WARRANTY OF ANY KIND IS MADE WITH REGARD TO ANY PRODUCT, COMPONENTS, DEVICES, MEDIA OR TREATMENT UNITS WHICH ARE MANUFACTURED BY OTHERS AND ARE INSTALLED IN CONNECTION WITH THE ECOPOD® PRODUCT. USE OF THESE PRODUCTS ARE AT YOUR OWN RISK.

CONDITIONS AND EXCLUSIONS

There are certain conditions or applications over which Infiltrator has no control. Defects or problems as a result of such conditions or applications are not the responsibility of Infiltrator and are NOT covered under this warranty. They include failure to install the ECOPOD® Product in accordance with instructions or applicable regulatory requirements or guidance and altering the ECOPOD® Product contrary to the installation instructions.

**Contact Infiltrator’s Technical Services Department
for assistance at 1-800-221-4436 or info@infiltratorwater.com**

U.S. Patents: 4,759,661; 5,017,041; 5,156,488; 5,336,017; 5,401,116; 5,401,459; 5,511,903; 5,716,163; 5,588,778; 5,839,844 Canadian Patents: 1,329,959; 2,004,564 Other patents pending. Infiltrator, Equalizer, Quick4, and SideWinder are registered trademarks of Infiltrator Water Technologies. Infiltrator is a registered trademark in France. Infiltrator Water Technologies is a registered trademark in Mexico. Contour, MicroLeaching, PolyTuff, ChamberSpacer, MultiPort, PosiLock, QuickCut, QuickPlay, SnapLock and StraightLock are trademarks of Infiltrator Water Technologies. PolyLok is a trademark of PolyLok, Inc. TUF-TITE is a registered trademark of TUF-TITE, INC. Ultra-Rib is a trademark of IPEX Inc.

© 2026 Infiltrator Water Technologies, LLC. All rights reserved. Printed in U.S.A.

K4514 0426