

MC-4500 Design Manual

StormTech® Chamber Systems for Stormwater Management

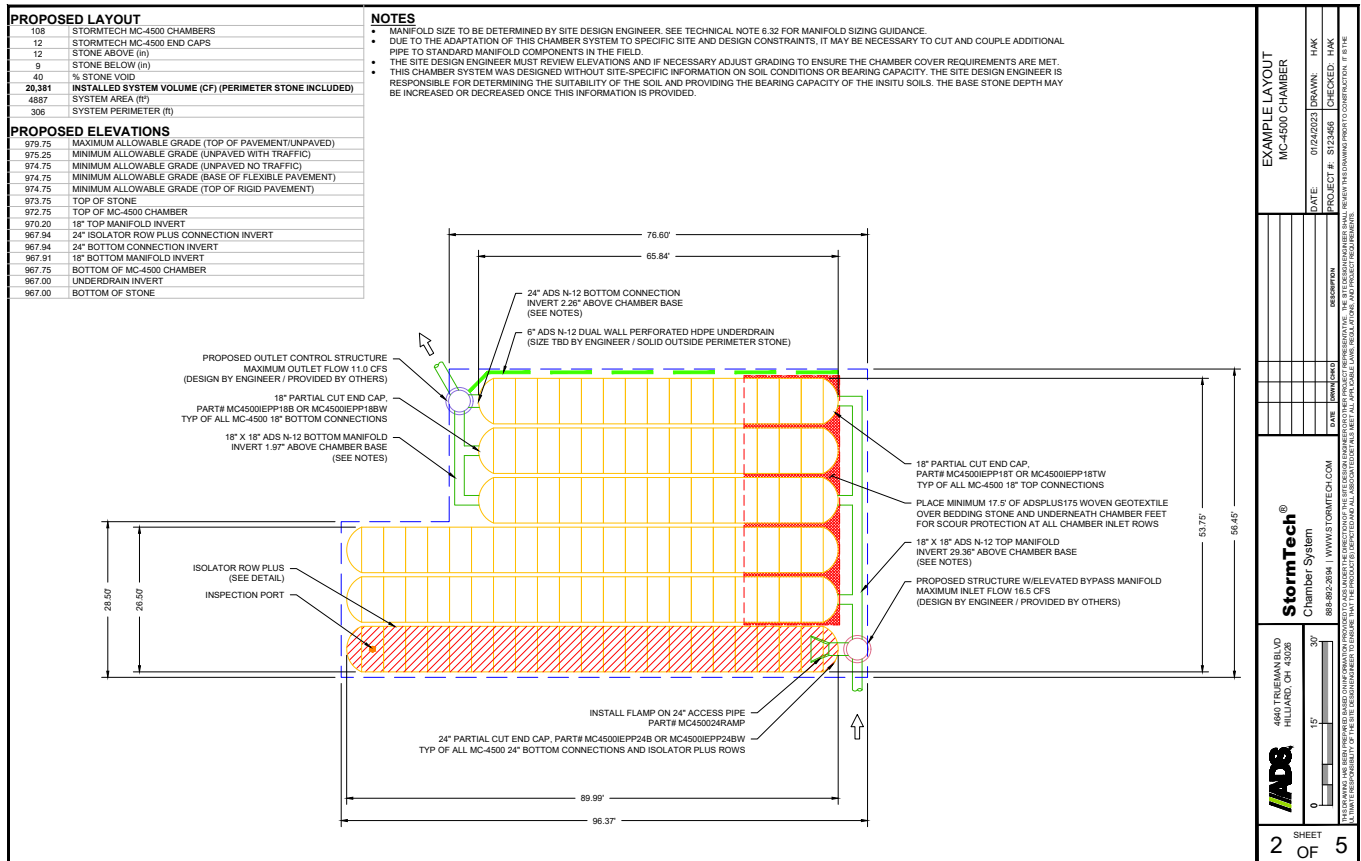

Table of Contents

1.0	Product Information	4
2.0	Foundation for Chambers.....	7
3.0	Required Materials/Row Separation.....	8
4.0	Hydraulics.....	10
5.0	Cumulative Storage Volume.....	12
6.0	System Sizing.....	15
7.0	Structural Cross Sections and Specifications	16
8.0	General Notes	17
9.0	Inspection and Maintenance	18

*For SC-160LP, SC-310 & DC-780 designs, please refer to the SC-160LP/SC-310/SC-740/DC-780 Design Manual.
 For MC-3500 & MC-7200 designs, please refer to the MC-3500 & MC-7200 Design Manual.

StormTech Engineering Services assists design professionals in specifying StormTech stormwater systems. This assistance includes the layout of chambers to meet the engineer's volume requirements and the connections to and from the chambers. They can also assist converting and cost engineering projects currently specified with ponds, pipe, concrete vaults and other manufactured stormwater detention/retention products. Please note that it is the responsibility of the site design engineer to ensure that the chamber bed layout meets all design requirements and is in compliance with applicable laws and regulations governing a project.



This manual is exclusively intended to assist engineers in the design of subsurface stormwater systems using StormTech chambers.

StormTech MC-4500 Chamber

Designed to meet the most stringent industry performance standards for superior structural integrity while providing designers with a cost-effective method to save valuable land and protect water resources. The StormTech system is designed primarily to be used under parking lots, thus maximizing land usage for private (commercial) and public applications. StormTech chambers can also be used in conjunction with Green Infrastructure, thus enhancing the performance and extending the service life of these practices.

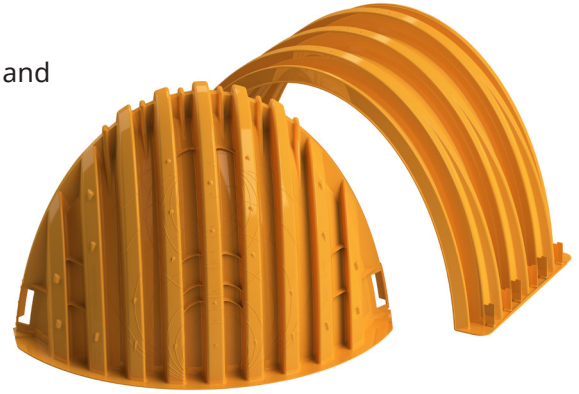

MC-4500 Chamber (not to scale)

Nominal Chamber Specifications

Size (L x W x H)
52" x 100" x 60"
1321 x 2540 x 1524 mm

Chamber Storage
106.5 ft³ (3.01 m³)

Min. Installed Storage*
162.6 ft³ (4.60 m³)

Weight
Nominal 125 lbs (56.7 kg)

Shipping
7 chambers/pallet
5 end caps/pallet
11 pallets/truck

*Assumes a minimum of 12" (300 mm) of stone above, 9" (230 mm) of stone below chambers, 9" (230 mm) of stone between chambers/end caps and 40% stone porosity.

MC-4500 End Cap (not to scale)

Nominal End Cap Specifications

Size (L x W x H)
38" x 90" x 61"
965 x 2286 x 1549 mm

End Cap Storage
39.5 ft³ (1.12 m³)

Min. Installed Storage*
115.3 ft³ (3.26 m³)

Weight
Nominal 90.0 lbs (40.8 kg)

*Assumes a minimum of 12" (300 mm) of stone above, 9" (230 mm) of stone below, 12" (300 mm) of stone perimeter, 9" (230 mm) of stone between chambers/end caps and 40% stone porosity.

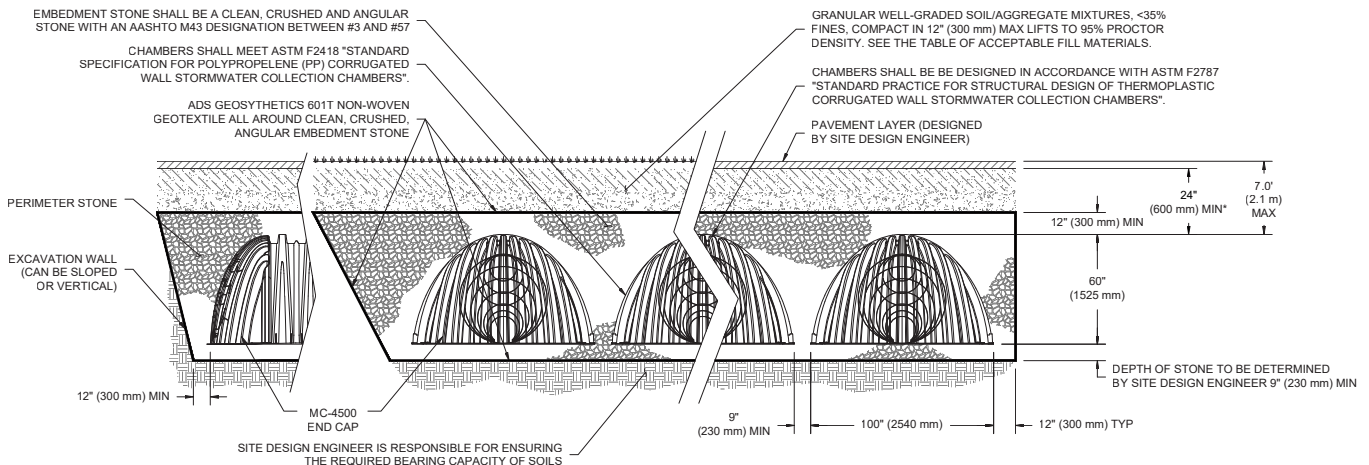
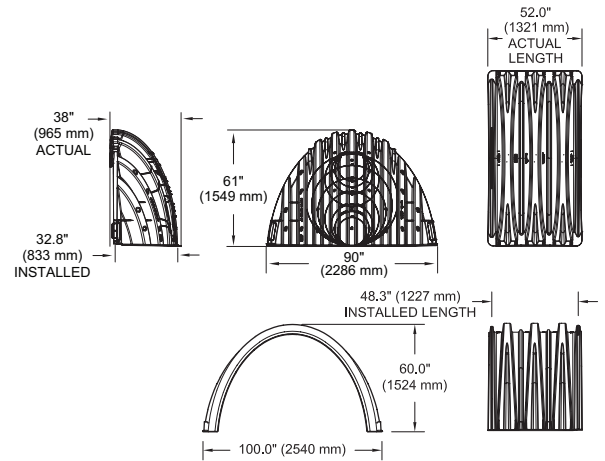

*MINIMUM COVER TO BOTTOM OF FLEXIBLE PAVEMENT. FOR UNPAVED INSTALLATIONS WHERE RUTTING FROM VEHICLES MAY OCCUR, INCREASE COVER TO 30" (750 mm).

StormTech MC-4500 Chamber

Storage Volume Per Chamber/End Cap ft³ (m³)

	Bare Unit Storage ft ³ (m ³)	Chamber/End Cap and Stone Volume — Stone Foundation Depth in. (mm)			
		9 (230)	12 (300)	15 (375)	18 (450)
MC-4500 Chamber	106.5 (3.02)	162.6 (4.60)	166.3 (4.71)	169.9 (4.71)	173.6 (4.91)
MC-4500 End Cap	39.5 (1.12)	115.3 (3.26)	111.9 (3.17)	121.9 (3.45)	125.2 (3.54)

Note: Assumes 9" (230 mm) row spacing, 40% stone porosity, 12" (300 mm) stone above and includes the bare chamber/end cap volume. End cap volume assumes 12" (300 mm) stone perimeter in front of end cap.

Amount of Stone Per Chamber

ENGLISH tons (yd ³)	Stone Foundation Depth			
	9"	12"	15"	18"
Chamber	7.4 (5.2)	7.8 (5.5)	8.3 (5.9)	8.8 (6.2)
End Cap	9.8 (7.0)	10.2 (7.3)	10.6 (7.6)	11.1 (7.9)
METRIC kg (m ³)	230 mm	300 mm	375 mm	450 mm
Chamber	6713 (4.0)	7076 (4.2)	7529 (4.5)	7983 (4.7)
End Cap	8890 (5.3)	9253 (5.5)	9616 (5.8)	10069 (6.0)

Note: Assumes 12" (300 mm) of stone above and 9" (230 mm) row spacing and 12" (300 mm) of perimeter stone in front of end caps.

Volume of Excavation Per Chamber/End Cap yd³ (m³)

	Stone Foundation Depth			
	9" (230 mm)	12" (300 mm)	15" (375 mm)	18" (450 mm)
Chamber	10.5 (8.0)	10.8 (8.3)	11.2 (8.5)	11.5 (8.8)
End Cap	9.7 (7.4)	10.0 (7.6)	10.3 (7.9)	10.6 (8.1)

Note: Assumes 9" (230 mm) of separation between chamber rows, 12" (300 mm) of perimeter in front of the end caps, and 24" (600 mm) of cover. The volume of excavation will vary as depth of cover increases.

Special applications will be considered on a project by project basis. Please contact our application department should you have a unique application for our team to evaluate.



1.0 Product Information

1.1 Product Design

StormTech's commitment to thorough product testing programs, materials evaluation and adherence to national standards has resulted in two more superior products. Like other StormTech chambers, the MC-4500 is designed to meet the full scope of design requirements of the American Society of Testing Materials (ASTM) International specification F2787 "Standard Practice for Structural Design of Thermoplastic Corrugated Wall Stormwater Collection Chambers" and produced to the requirements of the ASTM F 2418 "Standard Specification for Polypropylene (PP) Corrugated Stormwater Collection Chambers".

The StormTech MC-4500 chamber provides the full AASHTO safety factors for live loads and permanent earth loads. The ASTM F 2787 standard provides specific guidance on how to design thermoplastic chambers in accordance with AASHTO Section 12.12. of the AASHTO LRFD Bridge Design Specifications. ASTM F 2787 requires that the safety factors included in the AASHTO guidance are achieved as a prerequisite to meeting ASTM F 2418. The three standards provide both the assurance of product quality and safe structural design.

The design of larger chambers in the same tradition of our other chambers required the collaboration of experts in soil-structure interaction, plastics and manufacturing. Years of extensive research, including laboratory testing and field verification, were required to produce chambers that are ready to meet both the rigors of installation and the longevity expected by engineers and owners.

This Design Manual provides the details and specifications necessary for consulting engineers to design stormwater management systems using the MC-4500 chamber. It provides specifications for storage capacities, layout dimensions as well as requirements for design to ensure a long service life. The basic design concepts for foundation and backfill materials, subgrade bearing capacities and row spacing remain equally as pertinent for the MC-4500 as the SC-310, DC-780, MC-3500 and MC-7200 chamber systems. However, since many design values and dimensional requirements are different for these larger chambers than the SC-310 and DC-780 chambers, design manuals and installation instructions are not interchangeable.

This manual includes only those details, dimensions, cover limits, etc for the MC-4500 and is intended to be a stand-alone design guide for the MC-4500 chambers. A installation guide specifically for this chamber model has also been

published.

1.2 Technical Support

The StormTech Technical Services Department is available to assist the engineer with the layout of the MC-4500 chamber system and answer questions regarding all the StormTech chamber models. Call the Technical Services Department, email us at info@stormtech.com or contact your local StormTech representative.

1.3 MC-4500 Chamber

All StormTech chambers are designed to the full scope of AASHTO requirements without repeating end walls or other structural reinforcing. StormTech's continuously curved, elliptical arch and the surrounding angular backfill are the key components of the structural system. With the addition of patent pending integral stiffening ribs (**Figure 5**), the MC-4500 is assured to provide a long, safe service life. Like other StormTech chambers, the MC-4500 is produced from high quality, impact modified resins which are tested for short-term and long-term mechanical properties.

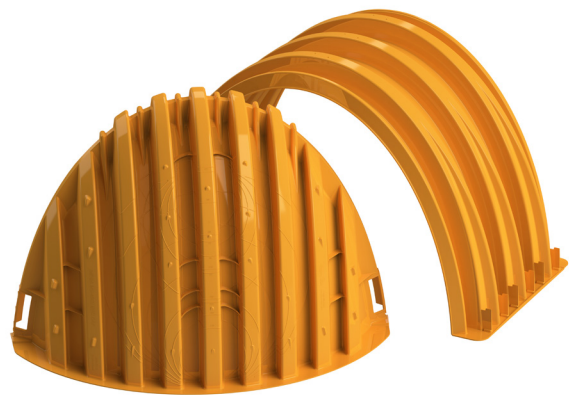

With all StormTech chambers, one chamber type is used for the start, middle and end of rows. Rows are formed by overlapping the upper joint corrugation of the next chamber over the lower joint corrugation of the previous chamber (**Figure 6**).

1.4 CHAMBER JOINTS

All StormTech chambers are designed with an optimized joining system. The height and width of the end corrugations have been designed to provide the required structural safety factors while providing an unobstructed flow path down each row.

1.0 Product Information

To assist the contractor, StormTech chambers are molded with simple assembly instructions and arrows that indicate the direction in which to build rows. The corrugation valley immediately adjacent to the lower joint corrugation is marked "Overlap Here - Lower Joint." The corrugation valley immediately adjacent to the upper joint corrugation is marked "Build This Direction - Upper Joint."

Two people can safely and efficiently carry and place chambers without cumbersome connectors, special tools or heavy equipment. Each row of chambers must begin and end with a joint corrugation. Since joint corrugations are of a different size than the corrugations along the body of the chamber, chambers cannot be field cut and installed. Only whole MC-4500 chambers

can be used. For system layout assistance contact StormTech.

1.5 MC-4500 End Caps

The MC-4500 end caps are easy to install. These end caps are designed with a corrugation joint that fits over the top of either end of the chamber. The end cap joint is simply set over the top of either of the upper or lower chamber joint corrugations (**Figure 7**).

The MC-4500 end cap has pipe cutting guides for 12"-42" (300 mm-1050 mm) bottom inverts and 12"-24" (300 mm-600 mm) top inverts (**Figure 8**).

Standard and custom pre-cored end caps are available.

Figure 5 - Chamber and End Cap Components

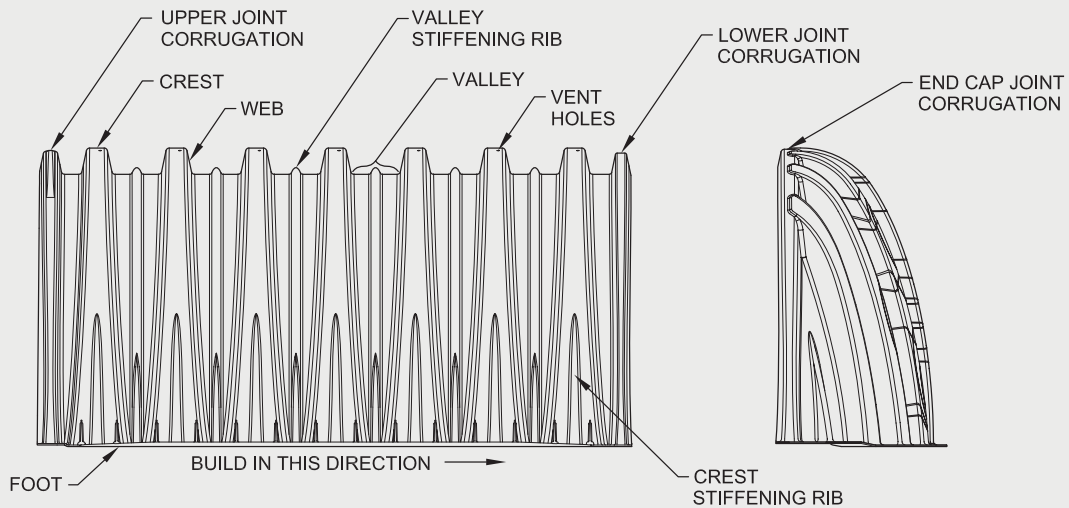

Figure 6 - Chamber Joint Overlap

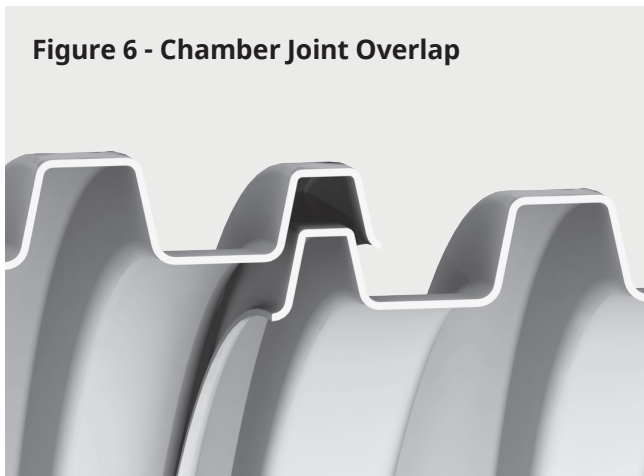
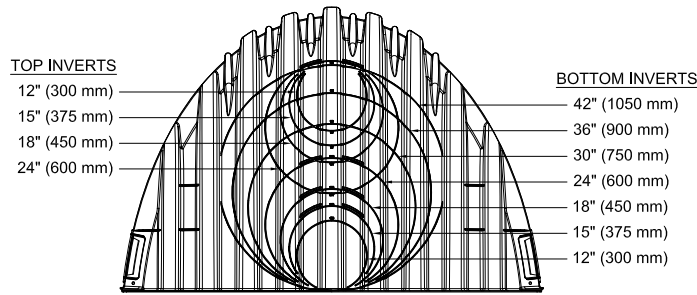

Figure 7 - End Cap Joint Overlap



1.0 Product Information

Figure 8—MC-4500 End Cap Inverts



2.0 Foundations for Chambers

2.1 FOUNDATION REQUIREMENTS

StormTech chamber systems can be installed in various soil types. The subgrade bearing capacity and the cover height over the chambers determine the required depth of clean, crushed, angular foundation stone below the chambers. Foundation stone, also called bedding, is the stone between the subgrade soils and the feet of the chamber. Flexible structures are designed to transfer a significant portion of both live and dead loads through the surrounding soils. Chamber systems accomplish this by creating load paths through the columns of embedment stone between and around the rows of chambers. This creates load concentrations at the base of the columns between the rows. The foundation stone spreads out the concentrated loads to distributed loads that can be supported by the subgrade soils.

Since increasing the cover height (top of chamber to finished grade) causes increasing soil load, a greater depth of foundation stone is necessary to distribute the load to the subgrade soils. **Table 1** specify the minimum required foundation depths for varying cover heights and allowable subgrade bearing capacities. These tables are based on StormTech service loads. The minimum required foundation depth is 9" (230 mm) for both chambers. For additional guidance on foundation stone design please see our Technical Note 6.22 - StormTech Subgrade Performance

2.2 WEAKER SOILS

StormTech has not provided guidance for subgrade bearing capacities less than 2000 pounds per square foot [(2.0 ksf) (96 kPa)]. These soils are often highly variable, may contain organic materials and could be more sensitive to moisture. A geotechnical engineer must be consulted if soils with bearing capacities less than 2000 psf (96 kPa) are present.

Figure 9 - Chamber Joint Overlap

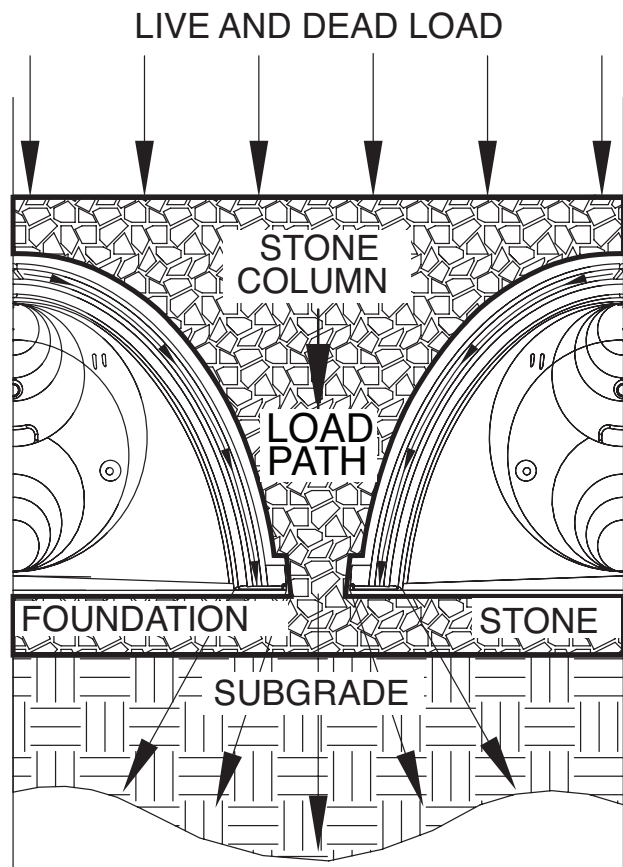

2.0 Foundations for Chambers

Table 1 - MC-4500 Minimum Required Foundation Depth in inches (millimeters)

Assumes 9" (230 mm) row spacing.

Cover Hgt. ft. (m)	Minimum Bearing Resistance for Service Loads ksf (kPa)																									
	4.4 (211)	4.3 (206)	4.2 (201)	4.1 (196)	4.0 (192)	3.9 (187)	3.8 (182)	3.7 (177)	3.6 (172)	3.5 (168)	3.4 (163)	3.3 (158)	3.2 (153)	3.1 (148)	3.0 (144)	2.9 (139)	2.8 (134)	2.7 (129)	2.6 (124)	2.5 (120)	2.4 (115)	2.3 (110)	2.2 (105)	2.1 (101)	2.0 (96)	
2.0 (0.61)	9 (230)	9 (230)	9 (230)	9 (230)	9 (230)	9 (230)	9 (230)	9 (230)	9 (230)	9 (230)	9 (230)	9 (230)	9 (230)	9 (230)	9 (230)	12 (300)	12 (300)	12 (300)	15 (375)	15 (375)	15 (375)	18 (450)	18 (450)	21 (525)	21 (525)	
2.5 (0.76)	9 (230)	9 (230)	9 (230)	9 (230)	9 (230)	9 (230)	9 (230)	9 (230)	9 (230)	9 (230)	9 (230)	9 (230)	9 (230)	12 (300)	12 (300)	12 (300)	15 (375)	15 (375)	15 (375)	18 (450)	18 (450)	18 (450)	21 (525)	21 (525)	24 (600)	
3.0 (0.91)	9 (230)	9 (230)	9 (230)	9 (230)	9 (230)	9 (230)	9 (230)	9 (230)	9 (230)	9 (230)	9 (230)	12 (300)	12 (300)	12 (300)	12 (300)	15 (375)	15 (375)	15 (375)	18 (450)	18 (450)	18 (450)	21 (525)	21 (525)	24 (600)	24 (600)	27 (675)
3.5 (1.07)	9 (230)	9 (230)	9 (230)	9 (230)	9 (230)	9 (230)	9 (230)	9 (230)	9 (230)	9 (230)	12 (300)	12 (300)	12 (300)	15 (375)	15 (375)	15 (375)	18 (450)	18 (450)	18 (450)	21 (525)	21 (525)	24 (600)	24 (600)	27 (675)	27 (675)	30 (750)
4.0 (1.22)	9 (230)	9 (230)	9 (230)	9 (230)	9 (230)	9 (230)	12 (300)	12 (300)	12 (300)	12 (300)	12 (300)	15 (375)	15 (375)	15 (375)	18 (450)	18 (450)	18 (450)	21 (525)	21 (525)	21 (525)	24 (600)	24 (600)	27 (675)	27 (675)	30 (750)	30 (750)
4.5 (1.37)	9 (230)	9 (230)	9 (230)	9 (230)	9 (230)	12 (300)	12 (300)	12 (300)	12 (300)	15 (375)	15 (375)	15 (375)	15 (375)	18 (450)	18 (450)	18 (450)	21 (525)	21 (525)	24 (600)	24 (600)	24 (600)	27 (675)	27 (675)	30 (750)	33 (825)	33 (825)
5.0 (1.52)	9 (230)	9 (230)	9 (230)	12 (300)	12 (300)	12 (300)	12 (300)	15 (375)	15 (375)	15 (375)	15 (375)	18 (450)	18 (450)	18 (450)	21 (525)	21 (525)	21 (525)	24 (600)	24 (600)	24 (600)	27 (675)	27 (675)	30 (750)	33 (825)	33 (825)	36 (900)
5.5 (1.68)	9 (230)	12 (300)	12 (300)	12 (300)	12 (300)	15 (375)	15 (375)	15 (375)	15 (375)	18 (450)	18 (450)	18 (450)	18 (450)	21 (525)	21 (525)	24 (600)	24 (600)	24 (600)	27 (675)	27 (675)	30 (750)	33 (825)	33 (825)	36 (900)	36 (900)	
6.0 (1.83)	12 (300)	12 (300)	12 (300)	12 (300)	12 (300)	15 (375)	15 (375)	15 (375)	18 (450)	18 (450)	18 (450)	21 (525)	21 (525)	21 (525)	24 (600)	24 (600)	27 (675)	27 (675)	30 (750)	30 (750)	33 (825)	33 (825)	36 (900)	36 (900)	36 (900)	
6.5 (1.98)	12 (300)	12 (300)	15 (375)	15 (375)	15 (375)	15 (375)	18 (450)	18 (450)	18 (450)	18 (450)	21 (525)	21 (525)	24 (600)	24 (600)	24 (600)	27 (675)	27 (675)	30 (750)	30 (750)	33 (825)	33 (825)	36 (900)	36 (900)	36 (900)	36 (900)	
7.0 (2.13)	15 (375)	15 (375)	15 (375)	15 (375)	18 (450)	18 (450)	18 (450)	18 (450)	21 (525)	21 (525)	21 (525)	24 (600)	24 (600)	24 (600)	27 (675)	27 (675)	30 (750)	30 (750)	33 (825)	36 (900)	36 (900)	36 (900)	36 (900)	36 (900)	36 (900)	

Note: The design engineer is solely responsible for assessing the bearing resistance (allowable bearing capacity) of the subgrade soils and determining the depth of foundation stone. Subgrade bearing resistance should be assessed with consideration for the range of soil moisture conditions expected under a stormwater system.

Figure 10 - MC-4500 Structural Cross Section Detail (Not to Scale)

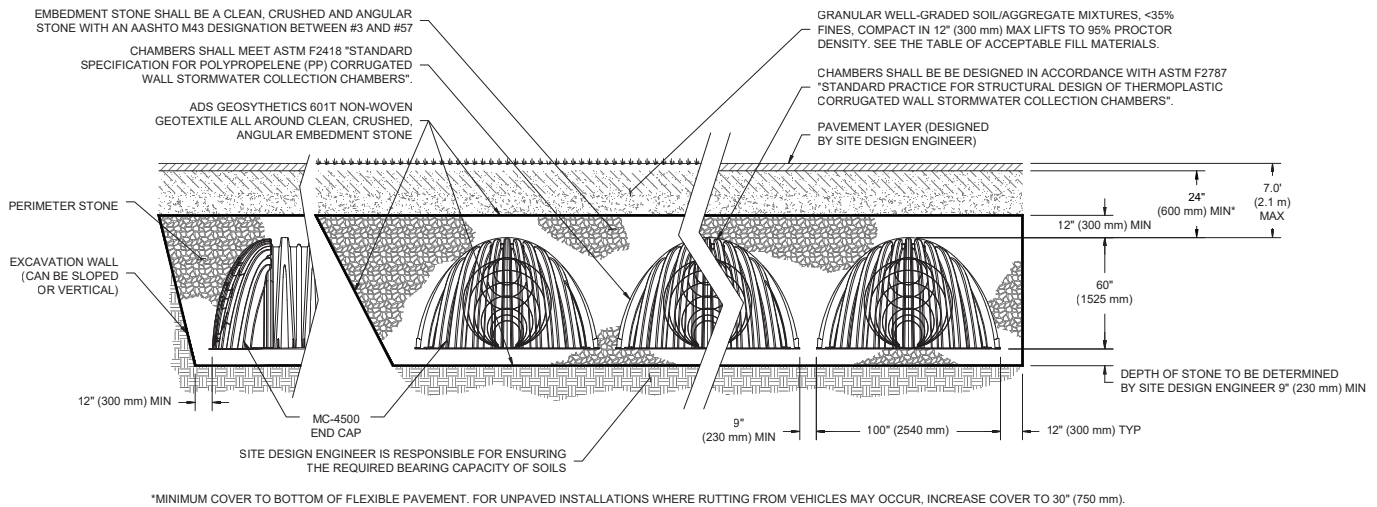

Special applications will be considered on a project by project basis. Please contact our applications department should you have a unique application for our team to evaluate.

3.0 Required Materials/Row Separation

3.1 Foundation and Embedment Stone

The stone surrounding the chambers consists of the foundation stone below the chambers and embedment stone surrounding the chambers. The foundation stone and embedment stone are important components of the structural system and also provide open void space for stormwater storage. **Table 2** provides the stone specifications that achieve both structural requirements and a porosity of 40% for stormwater storage. **Figure 11** specifies the extents of each backfill stone location.

Table 2 - Acceptable Fill Materials

Material Location	Description	AASHTO Designation	Compaction/Density Requirement
D	Final Fill: fill material for layer 'D' starts from the top of the 'C' layer to the bottom of flexible pavement or unpaved finished grade above. note that pavement subbase may be part of the 'D' layer	N/A	Prepare per site design engineer's plans. paved installations may have stringent material and preparation requirements.
C	Initial Fill: fill material for layer 'C' starts from the top of the embedment stone ('B' layer) to 24" (600 mm) above the top of the chamber. note that pavement subbase may be a part of the 'C' layer.	AASHTO M145 ¹ A-1,A-2-4,A-3 OR AASHTO M43 ¹ 3, 357, 4, 467, 5, 56, 57, 6, 67, 68, 7, 78, 8, 89, 9, 10	Begin compactoins after 24" (600 mm) of material over the chambers is reached. compact additional layers in 12" (300 mm) max lifts to a min. 95% proctor density for well-graded material and 95% relative density for processed aggregate materials.
B	Embedment Stone: fill surrounding the chambers form the foudation stone ('A' layer) to the 'C' layer above.	AASHTO M43 ¹ 3, 357, 4, 467, 5, 56, 57	No compaction required
A	Foundation Stone: fill below chambers from the subgrade up to the foot (bottom) of the chamber.	AASHTO M43 ¹ 3, 357, 4, 467, 5, 56, 57	Plate compact or roll to achieve a flat surface. ^{2, 3}

Note:

- The listed AASHTO designations are for gradations only. The stone must also be clean, crushed, angular. For example, a specification for #4 stone would state: "clean, crushed, angular no. 4 (AASHTO M43) stone".
- Stormtech compaction requirements are met for 'A' location materials when placed and compacted in 9" (230 mm) (max) lifts using two full coverages with a vibratory compactor.
- Where infiltration surfaces may be compromised by compaction, for standard design load conditions, a flat surface may be achieved by raking or dragging without compaction equipment. For special load designs, contact stormtech for compaction requirements.
- Where recycled concrete aggregate is used in layers 'A' or 'B' the material should also meet the acceptable criteria outlined in ADS Technical Note 6.20 "Recycled Concrete Structural Backfill".

Figure 11 - Fill Material Locations

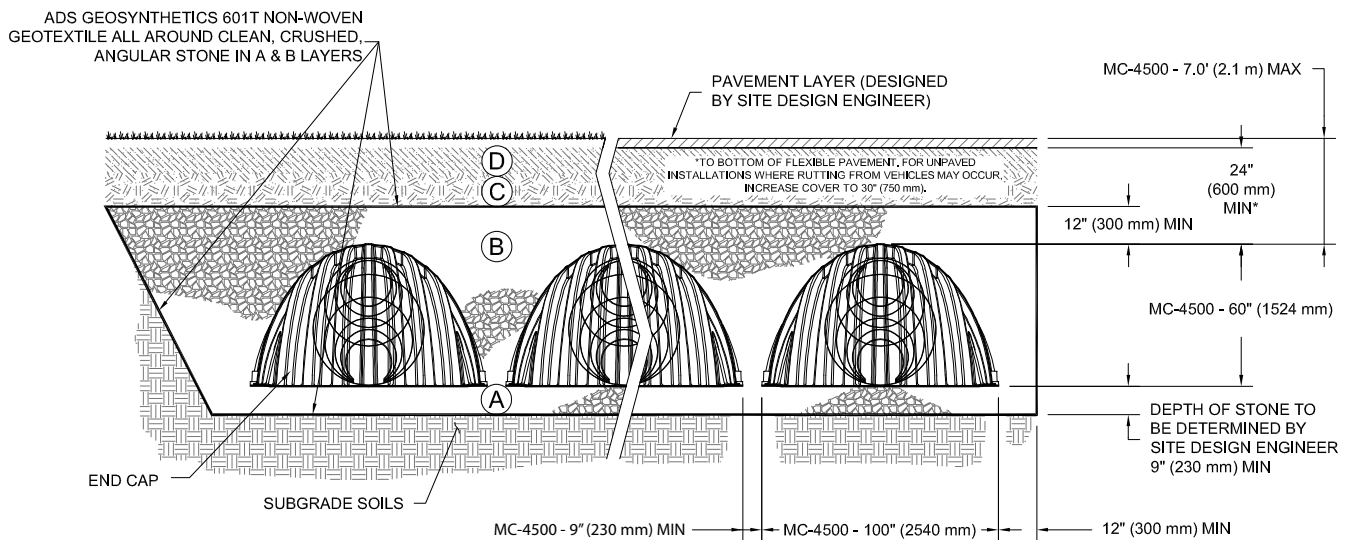

Once layer 'C' is placed, any soil/material can be placed in layer 'D' up to the finished grade. Most pavement subbase soils can be used to replace the materials of layer 'C' or 'D' at the design engineer's discretion.

3.0 Required Materials/Row Separation

3.2 Fill Above Chambers

Refer to **Table 2** and **Figure 11** for acceptable fill material above the clean, crushed, angular stone. StormTech requires a minimum of 24" (600 mm) from the top of the chamber to the bottom of flexible pavement. For non-paved installations where rutting from vehicles may occur StormTech requires a minimum of 30" (750 mm) from top of chamber to finished grade.

3.3 Geotextile Separation

A non-woven geotextile meeting AASHTO M288 Class 2 separation requirements must be installed to completely envelope the system and prevent soil intrusion into the crushed, angular stone. Overlap adjacent geotextile rolls per AASHTO M288 separation guidelines. Contact StormTech for a list of acceptable geotextiles.

3.4 Parallel Row Separation/ Perpendicular Bed Separation

Parallel Row Separation

The minimum installed spacing between parallel rows after backfilling is 9" (230 mm) for the MC-4500 chambers (measurement taken between the outside edges of the feet). Spacers may be used for layout convenience. Row spacing wider than the minimum spacing above may be specified.

Perpendicular Bed Separation

When beds are laid perpendicular to each other, a minimum installed spacing of 36" (900 mm) between beds is required.

3.5 Special Structural Designs

StormTech engineers may provide special structural designs to enable deeper cover depths or increase the capacity to carry higher live loads. Special designs may utilize the additional strength that can be achieved by compaction of embedment stone or by increasing the spacing between rows.

Increasing the spacing between chamber rows may also facilitate the application of StormTech chambers with either less foundation stone or with weaker subgrade soils. This may be a good option where vertical restrictions on site prevent the use of a deeper foundation.

Contact ADS Engineering Services for more information on special structural designs.



System Cross Section

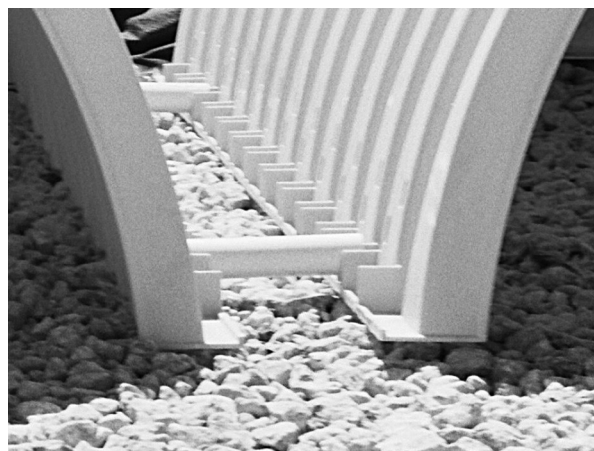

Minimum Row Spacing

4.0 Hydraulics

4.1 General

StormTech subsurface chamber systems offer the flexibility for a variety of inlet and outlet configurations. Contact the StormTech Technical Services Department or your local StormTech representative for assistance configuring inlet and outlet connections.

The open graded stone around and under the chambers provides a significant conveyance capacity ranging from approximately 0.54 cfs (15 l/s) to 8.5 cfs (240 l/s) for the MC-4500 chamber. The actual conveyance capacity is dependent upon stone size, depth of foundation stone and head of water. Although the high conveyance capacity of the open graded stone is an important component of the flow network, StormTech recommends that a system of inlet and outlet manifolds be designed to distribute and convey the peak flow through the chamber system.

It is the responsibility of the design engineer to provide the design flow rates and storage volumes for the stormwater system and to ensure that the final design meets all conveyance and storage requirements. However, StormTech will work with the design engineer to assist with manifold and chamber layouts that meet the design objectives.

4.2 The Isolator® Row Plus

The Isolator Row PLUS is a patented system that inexpensively captures total suspended solids (TSS) and debris and provides easy access for inspection and maintenance. In a typical configuration, a single layer of ADS PLUS fabric is placed between the chambers and the stone foundations. This fabric traps and filters sediments as well as protects the stone base during cleaning and maintenance. Each installed MC-4500 chamber and MC-4500 end cap provides 30.1 ft² (2.80 m²) and 12.8 ft² (1.19 m²) of bottom filter area respectively.

The Isolator Row PLUS can be configured for maintenance objectives or, in some regulatory jurisdictions, for water quality objectives. For water quality applications, the Isolator Row PLUS can be sized based on water quality volume or flow rate.

All Isolator Plus Rows require: 1) a manhole for maintenance access, 2) a means of diversion of flows to the Isolator Row PLUS 3) a high flow bypass and 4) FLAMP (Flared End Ramp). When used on an Isolator Row PLUS, a 24" FLAMP (flared end ramp) is attached to the inside of the inlet pipe with a provided threaded rod and bolt. The FLAMP then lays on top of the ADS PLUS fabric.. Flow diversion can be accomplished by either a weir in the upstream access manhole or simply by feeding the Isolator Row PLUS at a lower elevation than the high flow bypass. Contact StormTech for assistance sizing Isolator Plus Rows.

When additional stormwater treatment is required, StormTech systems can be configured using a treatment train approach where other stormwater BMPs are located in series.

Figure 12 - StormTech Isolator Row Plus Detail

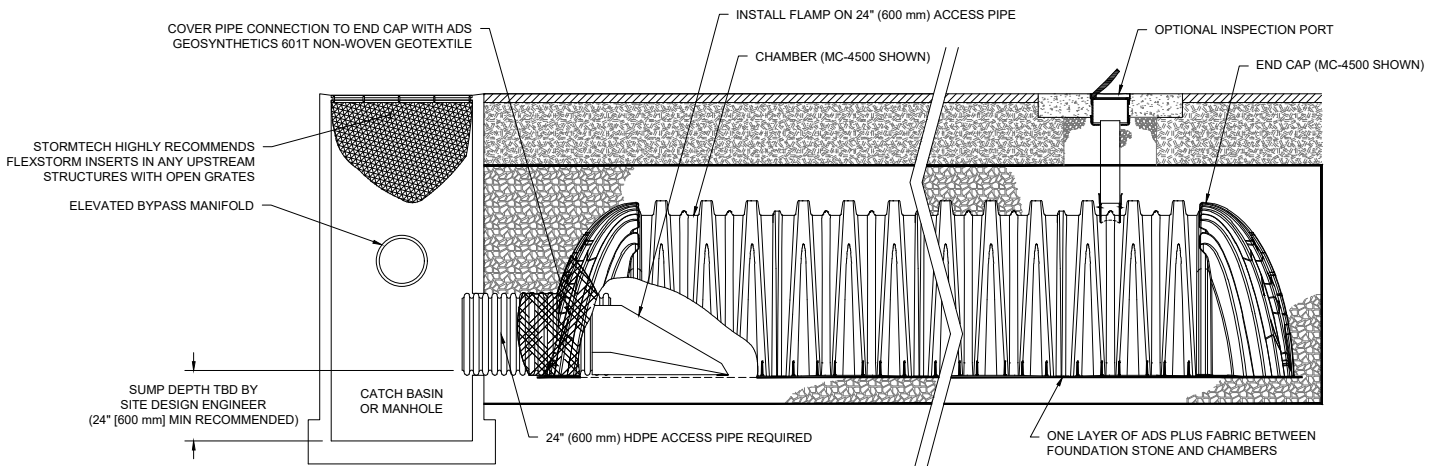

4.0 Hydraulics

Figure 13 - Typical Inlet Configuration With Isolator Row Plus and Scour Protection

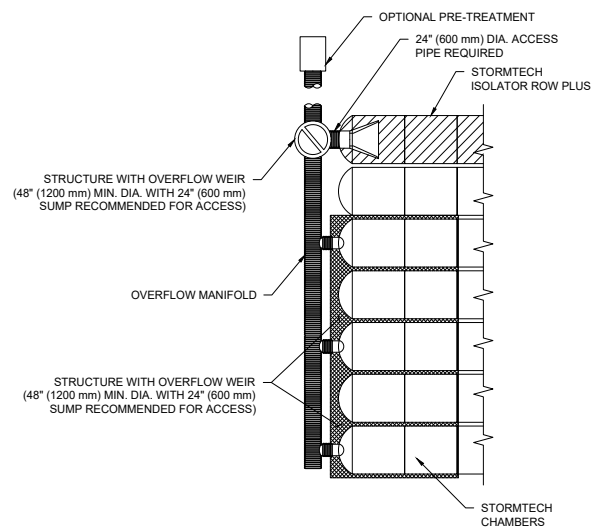

4.3 Inlet Manifolds

The primary function of the inlet manifold is to convey and distribute flows to a sufficient number of rows in the chamber bed such that there is ample conveyance capacity to pass the peak flows without creating an unacceptable backwater condition in upstream piping or scour the foundation stone under the chambers.

Manifolds are connected to the end caps either at the top or bottom of the end cap. Standard distances from the base of chamber to the invert of inlet and outlet manifolds connecting to StormTech end caps can be found in table 6. High inlet flow rates from either connection location produce a shear scour potential of the foundation stone. Inlet flows from top inlets also produce impingement scour potential. Scour potential is reduced when standing water is present over the foundation stone. However, for safe design across the wide range of applications, StormTech assumes minimal standing water at the time the design flow occurs.

To minimize scour potential, StormTech recommends the installation of woven scour protection fabric at each inlet row. This enables a protected transition zone from the concentrated flow coming out of the inlet pipe to a uniform flow across the entire width of the chamber for both top and bottom connections.

Allowable flow rates for design are dependent upon: the elevation of inlet pipe, foundation stone size and scour protection. With an appropriate scour protection geotextile installed from the end cap to at least 14.5 ft (4.42 m) in front of the inlet pipe for the MC-4500, for both top and bottom feeds, the flow rates listed in **Table 3** can be used for all StormTech specified foundation stone gradations.

***See StormTech's Tech Note 6.32 for manifold sizing guidance.**

Table 3 - Allowable Inlet Flows*

Inlet Pipe Diameter Inches (mm)	Allowable Maximum Flow Rate cfs (l/s)
12 (300)	2.48 (70)
15 (375)	3.5 (99)
18 (450)	5.5 (156)
24 (600)	9.5 (269)

*Assumes appropriate length of scour fabric per section 4.3

Table 4 - Maximum Outlet Flow Rate Capacities From StormTech Outlet Manifolds

Pipe Diameter	Flow (CFS)	Flow (L/S)
6" (150 mm)	0.4	11.3
8" (200 mm)	0.7	19.8
10" (250 mm)	1.0	28.3
12" (300 mm)	2.0	56.6
15" (375 mm)	2.7	76.5
18" (450 mm)	4.0	113.3
24" (600 mm)	7.0	198.2
30" (750 mm)	11.0	311.5
36" (900 mm)	16.0	453.1
42" (1050 mm)	22.0	623.0
48" (1200 mm)	28.0	792.9

Table 5 - Standard Distances From Base of Chamber to Invert of Inlet and Outlet Manifolds on StormTech MC-4500 End Caps

	Pipe Diameter	Inv. (IN)	Inv. (MM)
TOP	12" (300 mm)	35.69	907
	15" (375 mm)	32.72	831
	18" (450 mm)	29.36	746
	24" (600 mm)	23.05	585
BOTTOM	12" (750 mm)	1.55	34
	15" (900 mm)	1.7	43
	18" (1050 mm)	1.97	50
	24" (1200 mm)	2.26	57

5.0 Cumulative Storage Volumes

4.4 Outlet Manifolds

The primary function of the outlet manifold is to convey peak flows from the chamber system to the outlet control structure. Outlet manifolds are often sized for attenuated flows. They may be smaller in diameter and have fewer row connections than inlet manifolds. In some applications however, the intent of the outlet piping is to convey an unattenuated bypass flow rate and manifolds may be sized similar to inlet manifolds.

Since chambers are generally flowing at or near full at the time of the peak outlet flow rate, scour is generally not governing and outlet manifold sizing is based on pipe flow equations. In most cases, StormTech recommends that outlet manifolds connect the same rows that are connected to an inlet manifold. This provides a continuous flow path through open conduits to pass the peak flow without dependence on passing peak flows through stone.

The primary function of the underdrains is to draw down water stored in the stone below the invert of the manifold. Underdrains are generally not sized for conveyance of the peak flow.

The maximum outlet flow rate capacities from StormTech outlet manifolds can be found in **Table 5**.

Figure 14 - Typical Inlet, Outlet and Underdrain Configuration

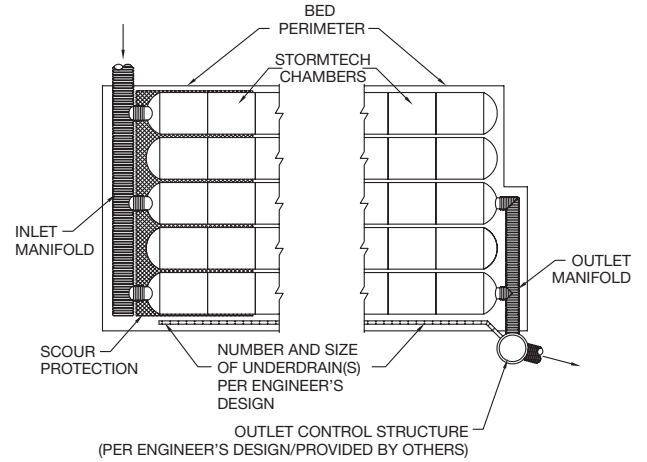
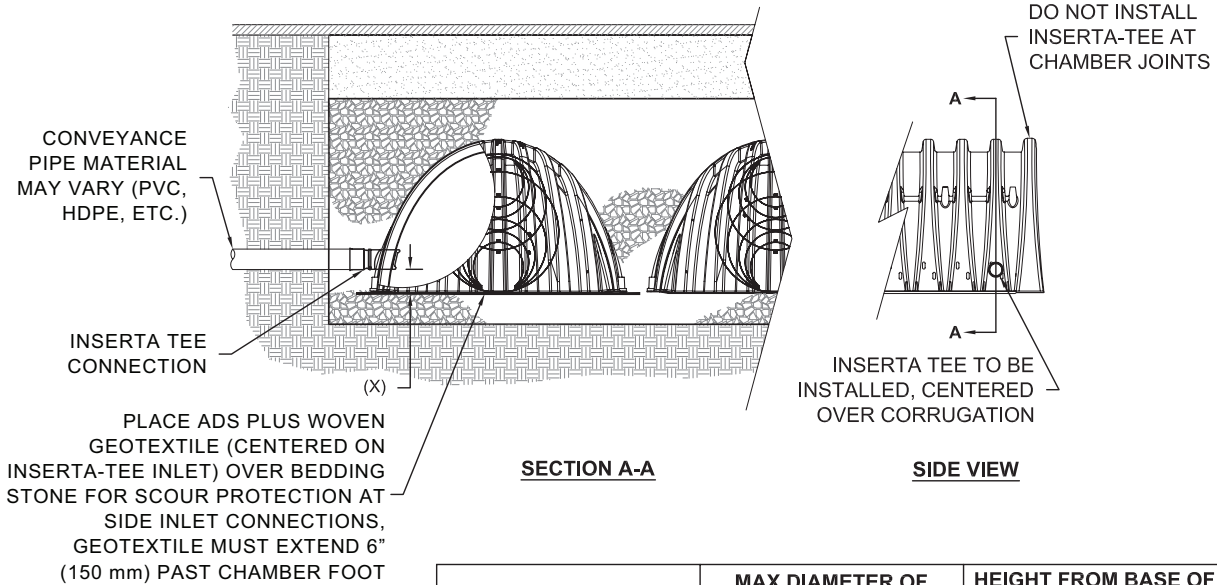

Figure 15 - Inserta Tee Detail



NOTE:
PART NUMBERS WILL VARY BASED ON INLET PIPE MATERIALS. CONTACT STORMTECH FOR MORE INFORMATION.

CHAMBER	MAX DIAMETER OF INSERTA TEE	HEIGHT FROM BASE OF CHAMBER (X)
MC-4500	12" (250 mm)	8" (200 mm)
INSERTA TEE FITTINGS AVAILABLE FOR SDR 26, SDR 35, SCH 40 IPS GASKETED & SOLVENT WELD, N-12, HP STORM, C-900 OR DUCTILE IRON		

5.0 Cumulative Storage Volumes

Tables 6 and 7 provide cumulative storage volumes for the MC-4500 chamber and end cap. These tables can be used to calculate the stage-storage relationship for the retention or detention system. Digital spreadsheets in which the number of chambers and end caps can be input for quick cumulative storage calculations are available at www.stormtech.com. For assistance with site-specific calculations or input into routing software, contact the StormTech Technical Services Department.

Table 6 – MC-4500 Incremental Storage Volume Per Chamber

Assumes 40% stone porosity. Calculations are based upon a 9" (230 mm) stone base under the chambers, 12" (300 mm) of stone above chambers, and 9" (230 mm) of spacing between chambers.

Depth of Water in System Inches (mm)	Cumulative Chamber Storage ft ³ (m ³)	Total System Cumulative Storage ft ³ (m ³)
81 (2057)	0.00	162.62 (4.065)
80 (2032)	0.00	161.40 (4.570)
79 (2007)	0.00	160.18 (4.536)
78 (1981)	Stone 0.00	158.98 (4.501)
77 (1956)	Cover 0.00	157.74 (4.467)
76 (1930)	0.00	156.62 (4.432)
75 (1905)	0.00	155.30 (4.398)
74 (1880)	0.00	154.09 (4.363)
73 (1854)	0.00	152.87 (4.329)
72 (1829)	0.00	151.65 (4.294)
71 (1803)	0.00	150.43 (4.294)
70 (1778)	0.00	149.21 (4.225)
69 (1753)	106.51 (3.016)	147.99 (4.191)
68 (1727)	106.47 (3.015)	146.75 (4.156)
67 (1702)	106.35 (3.012)	145.46 (4.119)
66 (1676)	106.18 (3.007)	144.14 (4.082)
65 (1651)	105.98 (3.001)	142.80 (4.044)
64 (1626)	105.71 (2.993)	141.42 (4.005)
63 (1600)	105.25 (2.981)	139.93 (3.962)
62 (1575)	104.59 (2.962)	138.31 (3.917)
61 (1549)	103.79 (2.939)	136.61 (3.869)
60 (1524)	102.88 (2.913)	134.85 (3.819)
59 (1499)	101.88 (2.885)	133.03 (3.767)
58 (1473)	100.79 (2.854)	131.16 (3.714)
57 (1448)	99.63 (2.821)	129.24 (3.660)
56 (1422)	98.39 (2.786)	127.28 (3.604)
55 (1397)	97.10 (2.749)	125.28 (3.548)
54 (1372)	95.73 (2.711)	123.25 (3.490)
53 (1346)	94.32 (2.671)	121.18 (3.490)
52 (1321)	92.84 (2.629)	119.08 (3.372)
51 (1295)	91.32 (2.586)	116.94 (3.311)
50 (1270)	89.74 (2.541)	114.78 (3.250)
49 (1245)	88.12 (2.495)	112.59 (3.188)
48 (1219)	86.45 (2.448)	110.37 (3.125)
47 (1194)	84.75 (2.400)	108.13 (3.062)
46 (1168)	83.00 (2.350)	105.86 (2.998)
45 (1143)	81.21 (2.300)	103.56 (2.933)
44 (1118)	79.38 (2.248)	101.25 (2.867)
43 (1092)	77.52 (2.195)	98.91 (2.801)
42 (1067)	75.62 (2.141)	96.55 (2.734)
41 (1041)	73.69 (2.087)	94.18 (2.667)
40 (1016)	71.72 (2.031)	91.78 (2.599)
39 (991)	69.73 (1.974)	89.36 (2.531)

Depth of Water in System Inches (mm)	Cumulative Chamber Storage ft ³ (m ³)	Total System Cumulative Storage ft ³ (m ³)
38 (965)	67.70 (1.917)	86.93 (2.462)
37 (948)	65.65 (1.859)	84.48 (2.392)
36 (914)	63.57 (1.800)	82.01 (2.322)
35 (889)	61.46 (1.740)	79.53 (2.252)
34 (864)	59.32 (1.680)	77.03 (2.181)
33 (838)	57.17 (1.619)	74.52 (2.110)
32 (813)	54.98 (1.557)	71.99 (2.038)
31 (787)	52.78 (1.495)	69.45 (1.966)
30 (762)	50.55 (1.431)	66.89 (1.894)
29 (737)	48.30 (1.368)	64.32 (1.821)
28 (711)	46.03 (1.303)	61.74 (1.748)
27 (686)	43.74 (1.239)	59.19 (1.675)
26 (680)	41.43 (1.173)	56.55 (1.601)
25 (610)	39.11 (1.107)	53.93 (1.527)
24 (609)	36.77 (1.041)	51.31 (1.453)
23 (584)	34.41 (0.974)	48.67 (1.378)
22 (559)	32.03 (0.907)	46.03 (1.303)
21 (533)	29.64 (0.839)	43.38 (1.228)
20 (508)	27.23 (0.771)	40.71 (1.153)
19 (483)	24.81 (0.703)	38.04 (1.077)
18 (457)	22.38 (0.634)	35.37 (1.001)
17 (432)	19.94 (0.565)	32.68 (0.925)
16 (406)	17.48 (0.495)	29.99 (0.849)
15 (381)	15.01 (0.425)	27.29 (0.773)
14 (356)	12.53 (0.355)	24.58 (0.696)
13 (330)	10.05 (0.284)	21.87 (0.619)
12 (305)	7.55 (0.214)	19.15 (0.542)
11 (279)	5.04 (0.143)	16.43 (0.465)
10 (254)	2.53 (0.072)	13.70 (0.388)
9 (229)	0.00	10.97 (0.311)
8 (203)	0.00	9.75 (0.276)
7 (178)	0.00	8.53 (0.242)
6 (152)	Stone 0.00	7.31 (0.207)
5 (127)	Cover 0.00	6.09 (0.173)
4 (102)	0.00	4.87 (0.138)
3 (76)	0.00	3.66 (0.104)
2 (51)	0.00	2.44 (0.069)
1 (25)	0.00	1.22 (0.035)

NOTE: Add 1.22 ft³ (0.035 m³) of storage for each additional inch (25 mm) of stone foundation. Contact StormTech for cumulative volume spreadsheets in digital format.

5.0 Cumulative Storage Volumes

Table 7– MC-4500 Incremental Storage Volume Per End Cap

Assumes 40% stone porosity. Calculations are based upon a 9" (230 mm) stone base under the chambers, 12" (300 mm) of stone above end caps, and 9" (230 mm) of spacing between end caps and 6" (150 mm) of stone perimeter.

Depth of Water in System Inches (mm)	Cumulative End Cap Storage ft ³ (m ³)	Total System Cumulative Storage ft ³ (m ³)
81 (2057)	0.00	115.28 (3.264)
80 (2032)	0.00	114.15 (3.232)
79 (2007)	0.00	113.02 (3.200)
78 (1981)	Stone	111.89 (3.168)
77 (1956)	Cover	110.76 (3.136)
76 (1930)	0.00	109.63 (3.104)
75 (1905)	0.00	108.50 (3.072)
74 (1880)	0.00	107.37 (3.040)
73 (1854)	0.00	106.24 (3.008)
72 (1829)	0.00	105.11 (2.976)
71 (1803)	0.00	103.98 (2.944)
70 (1778)	0.00	102.85 (2.912)
69 (1753)	39.54 (1.120)	101.72 (2.880)
68 (1727)	39.53 (1.119)	100.58 (2.848)
67 (1702)	39.50 (1.118)	99.43 (2.816)
66 (1676)	39.45 (1.117)	98.27 (2.783)
65 (1651)	39.38 (1.115)	97.10 (2.750)
64 (1626)	39.30 (1.113)	95.92 (2.716)
63 (1600)	39.19 (1.110)	94.73 (2.682)
62 (1575)	39.06 (1.106)	93.52 (2.648)
61 (1549)	38.90 (1.101)	92.29 (2.613)
60 (1524)	38.71 (1.096)	91.04 (2.578)
59 (1499)	38.49 (1.090)	89.78 (2.542)
58 (1473)	38.24 (1.083)	88.50 (2.506)
57 (1448)	37.97 (1.075)	87.21 (2.469)
56 (1422)	37.67 (1.067)	85.90 (2.432)
55 (1397)	37.34 (1.057)	84.57 (2.395)
54 (1372)	36.98 (1.047)	83.23 (2.357)
53 (1346)	36.60 (1.036)	81.87 (2.318)
52 (1321)	36.19 (1.025)	80.49 (2.279)
51 (1295)	35.75 (1.012)	79.10 (2.240)
50 (1270)	35.28 (0.999)	77.69 (2.200)
49 (1245)	34.79 (0.985)	76.26 (2.159)
48 (1219)	34.27 (0.970)	74.82 (2.119)
47 (1194)	33.72 (0.955)	73.36 (2.077)
46 (1168)	33.15 (0.939)	71.89 (2.036)
45 (1143)	32.57 (0.922)	70.40 (1.994)
44 (1118)	31.96 (0.905)	68.91 (1.951)
43 (1092)	31.32 (0.887)	67.40 (1.909)
42 (1067)	30.68 (0.869)	65.88 (1.866)
41 (1041)	30.00 (0.850)	64.35 (1.822)
40 (1016)	29.30 (0.830)	62.80 (1.778)

Depth of Water in System Inches (mm)	Cumulative Chamber Storage ft ³ (m ³)	Total System Cumulative Storage ft ³ (m ³)
39 (991)	28.58 (0.809)	61.23 (1.734)
38 (965)	27.84 (0.788)	59.65 (1.689)
37 (948)	27.07 (0.767)	58.07 (1.644)
36 (914)	26.29 (0.744)	56.46 (1.599)
35 (889)	25.48 (0.722)	54.85 (1.553)
34 (864)	24.66 (0.698)	53.23 (1.507)
33 (838)	23.83 (0.675)	51.60 (1.461)
32 (813)	22.98 (0.651)	49.96 (1.415)
31 (787)	22.12 (0.626)	48.31 (1.368)
30 (762)	21.23 (0.601)	46.65 (1.321)
29 (737)	20.32 (0.575)	44.97 (1.273)
28 (711)	19.40 (0.549)	43.29 (1.226)
27 (686)	18.48 (0.523)	41.61 (1.178)
26 (680)	17.54 (0.497)	39.91 (1.130)
25 (610)	16.59 (0.470)	38.21 (1.082)
24 (609)	15.62 (0.442)	36.50 (1.033)
23 (584)	14.64 (0.414)	34.78 (0.985)
22 (559)	13.66 (0.387)	33.07 (0.936)
21 (533)	12.66 (0.359)	31.33 (0.887)
20 (508)	11.65 (0.330)	29.60 (0.838)
19 (483)	10.63 (0.301)	27.85 (0.3789)
18 (457)	9.60 (0.272)	26.11 (0.739)
17 (432)	8.56 (0.242)	24.35 (0.690)
16 (406)	7.51 (0.213)	22.59 (0.640)
15 (381)	6.46 (0.183)	20.83 (0.590)
14 (356)	5.41 (0.153)	19.07 (0.540)
13 (330)	4.35 (0.123)	17.31 (0.490)
12 (305)	3.28 (0.093)	15.53 (0.440)
11 (279)	2.19 (0.062)	13.75 (0.389)
10 (254)	1.11 (0.031)	11.97 (0.339)
9 (229)	0.00	10.17 (0.288)
8 (203)	0.00	9.04 (0.256)
7 (178)	0.00	7.91 (0.224)
6 (152)	Stone	6.78 (0.192)
5 (127)	foundation	5.65 (0.160)
4 (102)	0.00	4.52 (0.128)
3 (76)	0.00	3.39 (0.096)
2 (51)	0.00	2.26 (0.064)
1 (25)	0.00	1.13 (0.032)

NOTE: Add 1.08 ft³ (0.031 m³) of storage for each additional inch (25 mm) of stone foundation. Contact StormTech for cumulative volume spreadsheets in digital format.

6.0 MC-4500 Chamber System Sizing

The following steps provide the calculations necessary for preliminary sizing of an MC-4500 chamber system. For custom bed configurations to fit specific sites, contact the StormTech Technical Services Department or your local StormTech representative.

1) Determine the amount of storage volume (Vs) required. It is the design engineer's sole

Table 8—Storage Volume Per Chamber/End Cap ft³ (m³)

	Bare Unit Storage ft ³ (m ³)	Chamber/End Cap and Stone Volume — Stone Foundation Depth in. (mm)			
		9 (230)	12 (300)	15 (375)	18 (450)
MC-4500 Chamber	106.5 (3.01)	162.6 (4.60)	166.3 (4.71)	169.9 (4.81)	173.6 (4.91)
MC-4500 End Cap	39.5 (1.12)	115.3 (3.26)	118.6 (3.36)	121.9 (3.45)	125.2 (3.54)

NOTE: Assumes 9" (230 mm) row spacing, 40% stone porosity, 12" (300 mm) stone above and includes the bare chamber/end cap volume. End cap volume assumes 12" (300 mm) stone perimeter.

responsibility to determine the storage volume required.

2) Determine the number of chambers (C) required.

To calculate the number of chambers required for adequate storage, divide the storage volume (Vs) by the storage volume of the chamber (from **Table 8**), as follows: **C = Vs / Storage Volume per Chamber**

3) Determine the number of end caps required.

The number of end caps (EC) required depends on the number of rows required by the project. Once the number of chamber rows is determined, multiply the number of chamber rows by 2 to determine the number of end caps required. **EC = No. of Chamber Rows x 2**

Note: Additional end caps may be required for systems having inlet locations within the chamber bed.

4) Determine additional storage provided by end caps.

End Caps will provide additional storage to the project. Multiply the number of end caps (EC) by the storage volume per end cap (ECS) to determine the additional storage (As) provided by the end caps. **As = EC x ECS**

5) Adjust number of chambers (C) to account for additional end cap storage (As). The original number of chambers (C) can now be reduced due to the additional storage in the end caps. Divide the additional storage (As) by the storage volume per chamber to determine the number of chambers that can be removed. **Number of chambers to remove = As/ volume per chamber**

NOTE: Additional storage exists in the stone perimeter as well as in the inlet and outlet manifold systems. Contact StormTech's Technical Services Department for assistance with determining the

number of chambers and end caps required for your project.

6) Determine the required bed size (S).

The size of the bed will depend on the number of chambers and end caps required:

MC-4500 area per chamber = 36.6 ft² (3.4 m²)

MC-4500 area per end cap = 23.9 ft² (2.2 m²)

S = (C x area per chamber) + (EC x area per end cap)

Note: It is necessary to add 12" (300 mm) of stone perimeter parallel to the chamber rows and 6" (150 mm) of stone perimeter from the base of all end caps. The additional area due to perimeter stone is not included in the area numbers above.

Table 9 - Amount of Stone Per Chamber

ENGLISH tons (yd ³)	Stone Foundation Depth			
	9"	12"	15"	18"
MC-4500	7.4 (5.2)	7.8 (5.5)	8.3 (5.9)	8.8 (6.2)
End Cap	9.8 (7.0)	10.2 (7.3)	10.6 (7.6)	11.1 (7.9)
METRIC kg (m ³)	230 mm	300 mm	375 mm	450 mm
MC-4500	6681 (4.0)	7117 (4.2)	7552 (4.5)	7987 (4.7)
End Cap	8890 (5.3)	9253 (5.5)	9616 (5.8)	10069 (6.0)

Note: Assumes 12" (300 mm) of stone above, and 9" (230 mm) row spacing, and 12" (300 mm) of perimeter stone in front of end caps.

7) Determine the amount of stone (Vst) required.

To calculate the total amount of clean, crushed, angular stone required, multiply the number of chambers (C) and the number of end caps (EC) by the selected weight of stone from **Table 10**.

Note: Clean, crushed, angular stone is also required around the perimeter of the system.

Table 10 - Vol. of Excavation Per Chamber/End Cap yd³ (m³)

	Stone Foundation Depth			
	9" (230 mm)	12" (300 mm)	15" (375 mm)	18" (450 mm)
MC-4500	10.5 (8.0)	10.8 (8.3)	11.2 (8.5)	11.5 (8.8)
End Cap	9.7 (7.4)	10.0 (7.6)	10.3 (7.9)	10.6 (8.1)

NOTE: Assumes 9" (230 mm) separation between chamber rows, 12" (300 mm) of perimeter in front of end caps, and 24" (600 mm) of cover. The volume of excavation will vary as the depth of cover increases.

8) Determine the volume of excavation (Ex) required.

Each additional foot of cover will add a volume of excavation of 1.4 yd³ (1.0 m³) per MC-4500 chamber and 1.4 yd³ (0.8 m³) per MC-4500 end cap.

9) Determine the area of geotextile (F) required.

The bottom, top and sides of the bed must be covered with a non-woven geotextile (filter fabric) that meets AASHTO M288 Class 2 requirements. The area of the sidewalls must be calculated and a 24" (600 mm) overlap must be included for all seams. Geotextiles typically come in 15 foot (4.57 m) wide rolls.

7.0 Structural Cross Sections and Specifications

Figure 16 - MC-4500 Structural Cross Section Detail (Not to Scale)

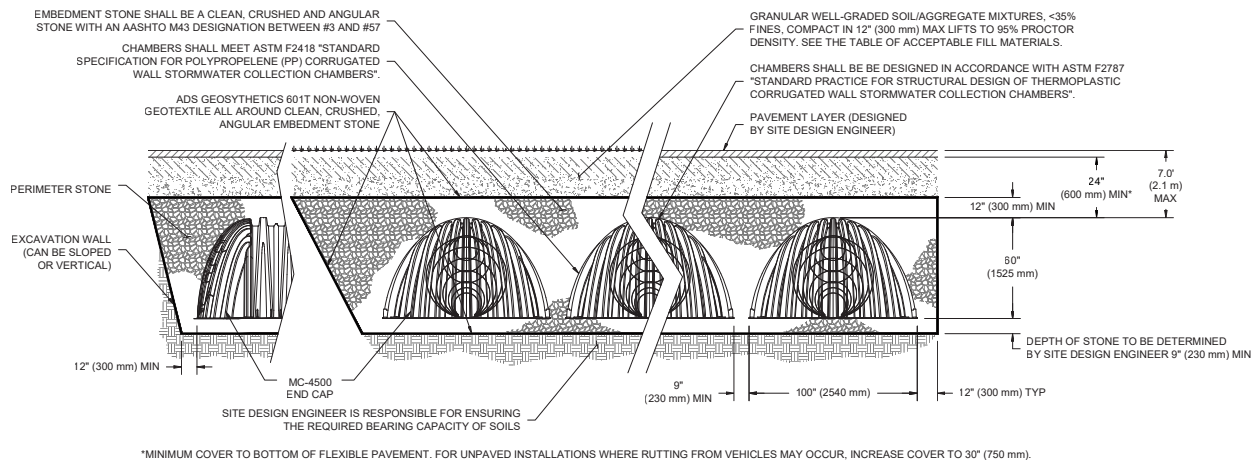

Special applications will be considered on a project by project basis. Please contact our application department should you have a unique application for our team to evaluate.

MC-4500 Stormwater Chamber Specifications

1. Chambers shall be stormtech MC-4500.
2. Chambers shall be arch-shaped and shall be manufactured from virgin, impact-modified polypropylene copolymers.
3. Chambers shall meet the requirements of astm F2418, "standard specification for polypropylene (PP) corrugated wall stormwater collection chambers" chamber classification 60x101.
4. Chamber rows shall provide continuous, unobstructed internal space with no internal supports that would impede flow or limit access for inspection.
5. The structural design of the chambers, the structural backfill, and the installation requirements shall ensure that the load factors specified in the AASHTO LRFD bridge design specifications, section 12.12, Are met for: 1) long-duration dead loads and 2) short-duration live loads, based on the aashto design truck with consideration for impact and multiple vehicle presences.
6. Chambers shall be designed, tested and allowable load configurations determined in accordance with ASTM F2787, "standard practice for structural design of thermoplastic corrugated wall stormwater collection chambers". Load configurations shall include: 1) instantaneous (<1 min) aashto design truck live load on minimum cover 2) maximum permanent (75-yr) cover load and 3) allowable cover with parked (1-week) aashto design truck.
7. Requirements for handling and installation:
 - To maintain the width of chambers during shipping and handling, chambers shall have integral, interlocking stacking lugs.
 - To ensure a secure joint during installation and backfill, the height of the chamber joint shall not be less than 3".
 - To ensure the integrity of the arch shape during installation, a) the arch stiffness constant shall be greater than or equal to 500 lbs/ft/%. The asc is defined in section 6.2.8 Of ASTM F2418. And b) to resist chamber deformation during installation at elevated temperatures (above 73° f / 23° c), chambers shall be produced from reflective gold or yellow colors.
8. Only chambers that are approved by the site design engineer will be allowed. Upon request by the site design engineer or owner, the chamber manufacturer shall submit a structural evaluation for approval before delivering chambers to the project site as follows:
 - The structural evaluation shall be sealed by a registered professional engineer.
 - The structural evaluation shall demonstrate that the safety factors are greater than or equal to 1.95 For dead load and 1.75 For live load, the minimum required by astm f2787 and by sections 3 and 12.12 Of the aashto lrfd bridge design specifications for thermoplastic pipe.
 - The test derived creep modulus as specified in astm f2418 shall be used for permanent dead load design except that it shall be the 75-year modulus used for design.

Chambers and end caps shall be produced at an ISO 9001 certified manufacturing facility.

8.0 General Notes

1. StormTech requires installing contractors to use and understand the latest **StormTech MC-4500 Construction Guide** prior to beginning system installation.
2. StormTech offers installation consultations to installing contractors. Contact our Technical Service Department or local StormTech representative at least 30 days prior to system installation to arrange a pre-installation consultation. Our representatives can then answer questions or address comments on the StormTech chamber system and inform the installing contractor of the minimum installation requirements before beginning the system's construction. Call 860-529-8188 to speak to a Technical Service Representative or visit www.stormtech.com to receive a copy of our Construction Guide.
3. StormTech requirements for systems with pavement design (asphalt, concrete pavers, etc.): Minimum cover is 24" (600mm) for the MC-4500 not including pavement; MC-4500 maximum cover is 7.0' (2.43 m) both including pavement. For designs with cover depths deeper than these maximums, please contact Stormtech. For installations that do not include pavement, where rutting from vehicles may occur, minimum required cover is increased to 30" (762 mm).
4. The contractor must report any discrepancies with the bearing capacity of the subgrade materials to the design engineer.
5. AASHTO M288 Class 2 non-woven geotextile (ADS601 or equal) (filter fabric) must be used as indicated in the project plans.
6. Stone placement between chamber rows and around perimeter must follow instructions as indicated in the most current version of StormTech MC-4500 Construction Guide.
7. Backfilling over the chambers must follow requirements as indicated in the most current version of StormTech MC-4500 Construction Guide.
8. The contractor must refer to StormTech MC-4500 Construction Guide for a Table of Acceptable Vehicle Loads at various depths of cover. This information is also available at the StormTech website: www.stormtech.com. The contractor is responsible for preventing vehicles that exceed StormTech requirements from traveling across or parking over the stormwater system. Temporary fencing, warning tape and appropriately located signs are commonly used to prevent unauthorized vehicles from entering sensitive construction areas.
9. The contractor must apply erosion and sediment control measures to protect the stormwater system during all phases of site construction per local codes and design engineer's specifications.
10. STORMTECH PRODUCT WARRANTY IS LIMITED. Contact StormTech for warranty information.

9.0 Inspection and Maintenance

9.1 Isolator Row Plus Inspection

Regular inspection and maintenance are essential to assure a properly functioning stormwater system. Inspection is easily accomplished through the manhole or optional inspection ports of an Isolator Row PLUS. Please follow local and OSHA rules for a confined space entry.

Inspection ports can allow inspection to be accomplished completely from the surface without the need for a confined space entry. Inspection ports provide visual access to the system with the use of a flashlight. A stadia rod may be inserted to determine the depth of sediment. If upon visual inspection it is found that sediment has accumulated to an average depth exceeding 3" (76 mm), cleanout is required.

A StormTech Isolator Row PLUS should initially be inspected immediately after completion of the site's construction. While every effort should be made to prevent sediment from entering the system during construction, it is during this time that excess amounts of sediments are most likely to enter any stormwater system. Inspection and maintenance, if necessary, should be performed prior to passing responsibility over to the site's owner. Once in normal service, a StormTech Isolator Row PLUS should be inspected bi-annually until an understanding of the sites characteristics is developed. The site's maintenance manager can then revise the inspection schedule based on experience or local requirements.

9.2 Isolator Row Plus Maintenance

JetVac maintenance is recommended if sediment has been collected to an average depth of 3" (76 mm) inside the Isolator Row PLUS. More frequent maintenance may be required to maintain minimum flow rates through the Isolator Row PLUS. The JetVac process utilizes a high pressure water nozzle to propel itself down the Isolator Row PLUS while scouring and suspending sediments. As the nozzle is retrieved, a wave of suspended sediments is flushed back into the manhole for vacuuming. Most sewer and pipe maintenance companies have vacuum/ JetVac combination vehicles. Fixed nozzles designed for culverts or large diameter pipe cleaning are preferable. Rear facing jets with an effective spread of at least 45" (1143 mm) are best. StormTech recommends a maximum nozzle pressure of 2000 psi be utilized during cleaning. The JetVac process shall only be performed on StormTech Rows that have ADS PLUS fabric over the foundation stone.

A FLAMP (flared end ramp) is attached to the inlet pipe on the inside of the chamber end cap to provide a smooth transition from pipe invert to fabric bottom. It is configured to improve chamber function performance over time by distributing sediment and debris that would otherwise collect at the inlet. It also serves to improve the fluid and solid flow back into the inlet pipe during maintenance and cleaning, and to guide cleaning and inspection equipment back into the inlet pipe when complete.



FLAMP (Flared End Ramp)



**A typical JetVac truck
(This is not a StormTech product.)**

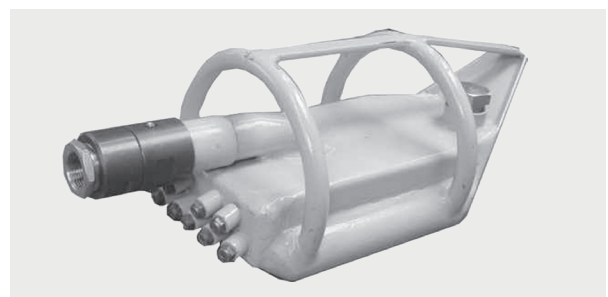

**Examples of culvert cleaning nozzles
appropriate for Isolator Row PLUS maintenance.
(These are not StormTech products).**

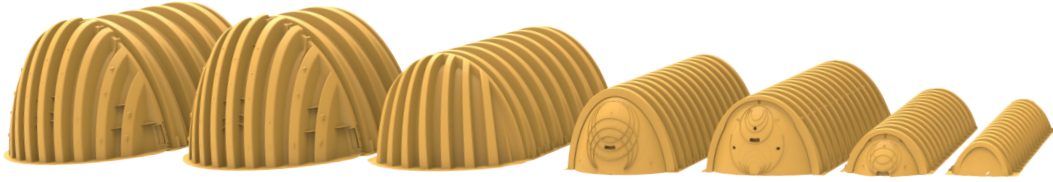

MC-7200

MC-4500

MC-3500

SC-800

DC-780

SC-310

SC-160LP

A Family of Products and Services for the Stormwater Industry:

MC-3500 and MC-7200 Chambers and End Caps
SC-160LP, SC-310 and SC-800 Chambers & End Caps
DC-780 Chambers and End Caps
Fabricated End Caps
Fabricated Manifold Fittings
Patented Isolator Row PLUS for Maintenance and
Water Quality
Chamber Separation Spacers
In-House System Layout Assistance
On-Site Educational Seminars
Worldwide Technical Sales Group
Centralized Product Applications Department
Research and Development Team
Technical Literature, O&M Manuals and Detailed CAD
drawings all downloadable via our Website

StormTech provides state-of-the-art products and services that meet or exceed industry performance standards and expectations. We offer designers, regulators, owners and contractors the highest quality products and services for stormwater management that Saves Valuable Land and Protects Water Resources.

adspipe.com

800-821-6710