

April 2026

ECOPOD[®]-Edge

FIXED FILM WASTEWATER TREATMENT SYSTEM

INSTALLATION, OPERATION AND MAINTENANCE MANUAL

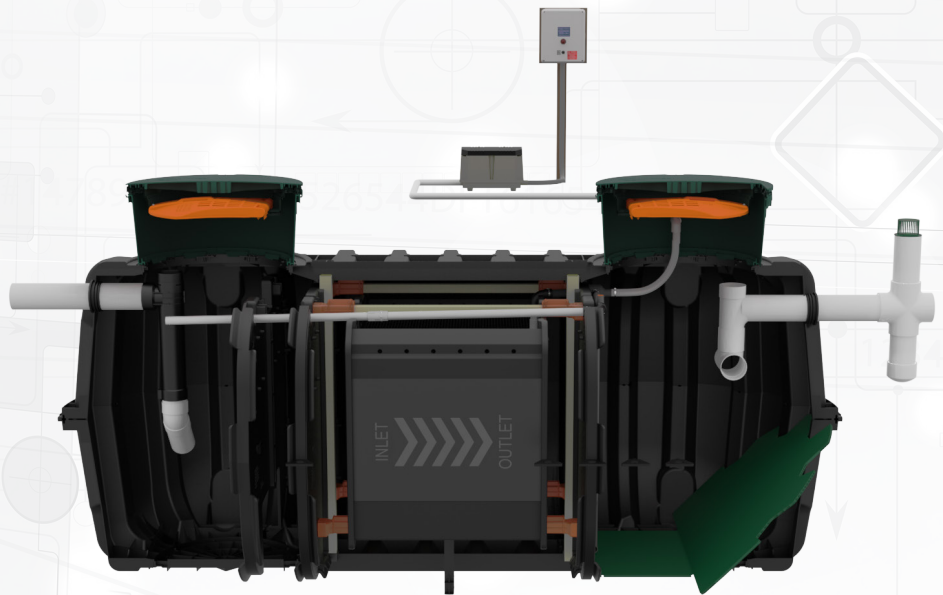

Infiltrator Water Technologies
4 Business Park Road
P.O. Box 768
Old Saybrook, CT 06475-0768
(800) 221-4436
www.infiltratorwater.com
info@infiltratorwater.com

TABLE OF CONTENTS

Distributor and Homeowner Notes.....	2
ECOPOD-Edge® Treatment Systems Notice	3
Introduction.....	4
Introduction and Homeowner Manual	4
Sampling.....	7
Installation Instructions.....	8
Troubleshooting Guide.....	9
Specifications.....	11
CP2210R2 Schematic	12
LW250 Schematic	14
ECOPOD-EDGE Series Data Plates	15
Service Policy	15
Warranty	16
ECOPOD®-EDGE Installation, Operation and Maintenance Manual: Edge500 Addendum.....	17-19

NOTE: To the installer: Please make sure you provide this manual to the owner of the equipment or to the responsible party who maintains the system.

DISTRIBUTOR AND HOMEOWNER NOTES

1. The Infiltrator Water Technologies' Model Edge500 has been tested by Gulf Coast Testing, LLC and conforms to NSF/ANSI Standard 40 and 245, Class 1 effluent requirements.
2. State and/or local regulations govern the installation and use of individual Aerobic Wastewater Treatment Systems and must be complied with.

Consult your local Sanitarian/Regulatory Agency prior to installation.

HOMEOWNER RECORDS	
DATE OF INSTALLATION:	_____
S/N:	_____
INSTALLED BY:	_____
DISTRIBUTOR:	_____
SERVICE PROVIDER:	_____

This booklet provides operations, installation and warranty information on the TREATMENT PLANT ONLY. Other components manuals, such as dosing equipment or drip irrigation, require additional operations and carry separate warranties. Be sure that you have all of the correct manuals for each of the component pieces in your system. Contact your installer or call (800) 221-4436.

INTRODUCTION AND HOMEOWNER MANUAL

THE INFILTRATOR AEROBIC WASTEWATER TREATMENT SYSTEM AND HOW IT WORKS

The ECOPOD-Edge Fixed Film Wastewater Treatment System you have purchased produces high quality water suitable for various dispersal methods. It is used to enhance your on-site wastewater dispersal system. You can be proud that by purchasing your ECOPOD-Edge system, with a minimum amount of maintenance, you can directly contribute to a cleaner, safer environment.

All wastewater treatment systems of this type work by using bacteria that nature provides. By pumping air into the system, aerobic bacteria grow and thrive in large numbers. This population of bacteria speeds up the process of breaking down domestic wastewater, making it safer to release into the environment. This entire process takes place within the walls of your specially designed ECOPOD-Edge Fixed Film Wastewater Treatment System. The result of this process is a clear, odorless discharge.

By following a few simple steps that you will find in this manual, your ECOPOD-Edge Fixed Film Wastewater Treatment System will provide you with years of service and the knowledge that you are doing your part to protect public health and our groundwater, lakes, rivers, and streams.

The ECOPOD-Edge Fixed Film Wastewater Treatment System may be only one of several components required by your permitting authority to provide a complete on-site system.

PROCESS DESCRIPTION

The ECOPOD-Edge Fixed Film Wastewater Treatment Systems are devices that house an engineered plastic media specifically designed to treat domestic wastewater. There are no moving mechanical parts or filters in the chamber that houses the ECOPOD-Edge.

Wastewater first enters a pretreatment/settling chamber similar to a conventional septic tank. In this chamber, debris and settleable solids settle to the bottom and are decomposed by anaerobic bacteria. The clarified wastewater then enters the ECOPOD-Edge, which is submerged in a separate chamber, where it is introduced into an oxygen rich environment. An external aerator is connected to the ECOPOD-Edge and provides the necessary air to the system. In this oxygen rich environment, a colony of bacteria, called the biomass, develops and is capable of digesting (breaking down) biodegradable waste. This is a continuous process as the biomass is supplied with incoming wastewater and oxygen. The aerator is also used to create an airlift in the ECOPOD-Edge that recirculates flow back to the pretreatment tank or chamber.

In this system conditions are more favorable to attached growth bacteria. This means that other types of systems such as accumulating settled sludge, floating sludge, and washouts are greatly reduced or eliminated. In addition to organic molecules that impose a biochemical oxygen demand (BOD) and total suspended solids (TSS) entering the system, ammonia nitrogen is also a component of domestic wastewater that significantly reduces water quality. Nitrification of the ammonia and denitrification of nitrates occur within the ECOPOD-Edge system. The recirculation from the airlift assembly is used to achieve increased total nitrogen reduction.

HOMEOWNER CARE AND OPERATION INSTRUCTIONS

The ECOPOD-Edge Fixed Film Wastewater Treatment System has been designed and built to provide long term, reliable and efficient service. Once installed (see installation instructions), the unit will operate with a minimum amount of attention.

Please reference the system's Data Plates that are located on the aerator and the alarm panel in the event that a problem arises or service is required.

The following should be performed as checks for system functioning:

Daily

Observe the warning device, which comes on when the power to the aerator has been interrupted, the air supply system has malfunctioned, or there is a high-water level in the treatment plant. If the alarm is activated, check for a blown fuse or thrown circuit breaker. Check the aerator to be sure it is operating. Once accustomed to the soft humming sound of a properly operating unit, any unusual noise is an indication of malfunction. If an unusual noise is detected or total failure is observed, call an authorized Infiltrator service provider or dealer/distributor.

Weekly

Check the treatment plant for offensive odor. If such a condition should develop, call an authorized Infiltrator service provider or dealer/distributor.

THE FOLLOWING CAN NEGATIVELY IMPACT THE TREATMENT PERFORMANCE OF YOUR SYSTEM. TO MINIMIZE MAINTENANCE AND ENSURE HIGH QUALITY EFFLUENT, IT IS STRONGLY RECOMMENDED THAT THE FOLLOWING ARE NOT DISCARDED INTO YOUR SYSTEM:

- Greases, fats, or oils
- Pesticides, herbicides, or any other toxins
- Paints, household chemicals, automobile fluids or mop water
- Non-biodegradable items such as cigarette butts, rags, feminine hygiene products, disposable diapers, condoms, hair, bandages, coffee grounds, paper towels, plastic or metallic objects, etc.
- Citrus products, oranges, lemons, grapefruit, etc.
- Septic system additives as they may do more harm than good

HOMEOWNER MANUAL

- Hydraulic overload due to excessive water use or inflow from other sources such as rain gutters
- Home brewery waste, strong medicines, and antibiotics.
- Strong disinfectants
- Discharge from water softeners
- Antibacterial soaps and excessive amounts of bleach should be avoided

The following practices will increase the intervals between maintenance/service calls:

- Recommended detergents are powdered, low-sudsing, low phosphates and biodegradable. Fabric softener dryer sheets are recommended rather than using liquid fabric softeners.
- Use non-chlorine, biodegradable and non-toxic cleaning products such as baking soda.
- Use garbage disposals moderately. Dispose of food waste, grease, etc. in the solid waste bin when possible.
- Laundry loads should be spread out over the week. Multiple loads on one day or half loads are not recommended.

SYSTEMS REQUIRING PUMPOUTS DUE TO THE ABOVE VIOLATIONS ARE NOT COVERED BY THE WARRANTY.

The ECOPOD-Edge Wastewater Treatment Systems are designed to handle domestic wastewater from a typical residential home; nothing else should go into them. For anything other than domestic wastewater, contact Infiltrator Water Technologies.

SAFETY WARNINGS

The proper operation of this or any other home sewage system depends upon proper organic loading and the life of the microorganisms inside the system. Infiltrator is not responsible for the in-field operation of a system, other than the mechanical and structural workings of the plant itself. Infiltrator Water Technologies cannot control the amount of harsh chemicals or other harmful substances that may be discharged into the system by the occupants of a household; we can only provide a comprehensive owner's manual that outlines substances that should be kept out of the system.

Hydraulic overloading (flows in excess of design flow) may cause the sewage treatment system not to perform to the fullest capabilities.

Ants have been shown to be destructive to the aerator. Regular care should be taken to prevent infestation of ants near the system. Damage or destruction by ants is not covered under manufacturer's warranty.

Your state or local health department may require other pieces of equipment to function separately or in conjunction with equipment manufactured by Infiltrator Water Technologies. Infiltrator Water Technologies is not responsible for the mechanical or electrical safety of equipment it does not manufacture or supply with its fixed film wastewater treatment system. Care should be used when evaluating the electrical or mechanical safety of equipment manufactured by others. This may include but is not limited to electrical control panels or aerators. If electrical service has not been installed for checking air distribution system during installation, and if an extension cord is used to test the aerator, never leave the extension cord plugged in.

Remove the extension cord after testing is completed.

DUE TO A POSSIBLE FIRE HAZARD, DO NOT PLUG INTO SERVICE EQUIPMENT ON POWER POLE AND DO NOT USE EXTENSION CORDS. ALL ELECTRICAL WORK PERFORMED BY THE INSTALLER OR OTHERS MUST BE IN ACCORDANCE WITH THE NATIONAL ELECTRICAL CODE AND LOCAL CODES.

MAINTENANCE

Ongoing Maintenance and Care

EVERY SIX MONTHS FOR FIRST TWO YEARS AFTER INSTALLATION

Annually or as required by state or local requirements thereafter the initial two years. Performed by a certified service provider.

- **Recirculation Flow**
- **Air Filter**
- **Check that the alarm on the panel is working**
- **Effluent color and clarity**
- **Sludge Level**

TOOLS REQUIRED:

- | | |
|--|--|
| <input type="checkbox"/> Eye Protection | <input type="checkbox"/> Hand Cleaner |
| <input type="checkbox"/> Rubber Gloves | <input type="checkbox"/> Hose and Water Access |
| <input type="checkbox"/> Sludge-Measuring Device | <input type="checkbox"/> Paper Towels |
| <input type="checkbox"/> Screwdriver Set | <input type="checkbox"/> Rags |
| <input type="checkbox"/> Socket and Ratchet Set | |

- Ensure no flow is coming from the home during the following maintenance procedure. Before turning off power to the aerator, open the lid on the inlet side of the tank and check to ensure water is flowing through the return assembly. The recirculation pipe will be visible from the access riser on the inlet end of the tank; location shown below.

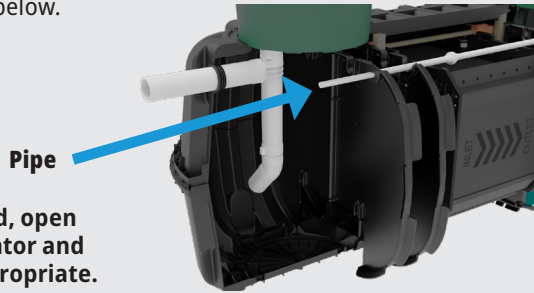

Once confirmed, open breaker to aerator and proceed as appropriate.

- Inspect the air filter on the aerator. Rinse with warm water and allow filter to dry completely before reinstalling or replace if necessary. (See installation instructions.) Do not use oil or other solvents.
- Inspect effluent quality's color, turbidity and check for odor.
- Collect a sample from the pretreatment and clarifier chambers to determine the sludge level described in the "Solids Removal" section.
- The homeowner must be notified in writing if any improper operation is observed and cannot be corrected at the time of service.

SOLIDS REMOVAL

Determination of the need for solids removal can be done with a sludge judge sample. The sludge judge should be used to measure the sludge layer thickness in the pretreatment compartment of the tank as accessible through the first riser on the tank inlet side. Several depth samples should be taken and if the highest recorded value of the sludge layer is greater than 20 inches in the primary compartment, contact your local authorized sewage disposal service to have the tank pumped out and disposed of properly.

Pump-Out Procedure

- Ensure the aerator is in the off position.
- Insert hose in through the back riser while using caution to avoid impacts with plumbing observed through the manhole.
- The clarifier baffle is visible from the back riser if looking under the manhole toward the inlet side of the tank. This baffle contains a window at the bottom of each side near the tank wall.
- While pumping from the outlet-side riser, position the intake of the hose near the bottom-sides of the clarifier baffle. Each bottom side of the baffle will need to be accessed with the hose by standing on that side of the riser to avoid the hose interacting with the recirculation intake positioned at the bottom-center of the clarifier baffle.
- The system is designed to pull most biosolids from the aerobic reaction zone on the other side of the clarifier baffle. However, some biosolids are to remain by design within the corrugations of the tank bottom. The solids remaining in the zone after pumping from the windows shall remain by design for rapid re-start to steady output.
- Insert the hose into the inlet-side riser and between the inlet and the surge baffle visible from the manhole. There is a 16" window centered at the bottom of this baffle. The hose can be moved under the window or inserted on the opposing side of the inlet to evacuate solids from both sides of the surge baffle as needed.
- If a substantial amount of solids (inches) remain in view at the bottom of the window on each side of the clarifier baffle, water should be returned with the hose and then re-evacuated with high velocity to pull the solids through.

NOTE: THE COST ASSOCIATED WITH PUMPING THE TREATMENT SYSTEM IS NOT COVERED UNDER WARRANTY AND IS NOT INCLUDED IN THE SERVICE POLICY.

SEASONAL USE GUIDELINES OF ECOPOD-EDGE

These guidelines are for conditions as outlined below and apply for systems that are not in use for periods of time indicated. Site conditions not covered by the following must be forwarded to Infiltrator for recommended guidelines to meet the particular site conditions.

1. System not in use for more than one month and less than three months. Electrical power is left on and there are no frost conditions.
 - Leave aerator on.
 - Leave system running.
2. System not in use more than three months. Electrical power is turned off and there are no frost conditions.
 - Remove all materials and liquid from tank.
 - Refill with clean water.
 - Turn off aerator.
3. System not in use more than three months. Electrical power is on and there are no frost conditions.
 - Leave aerator on and system running; OR
 - Remove all solids and liquid from tank.
 - Refill with clean water.

MAINTENANCE AND SAMPLING

4. System not in use. Electrical power is turned off and there are frost conditions.
 - Remove all solids and liquid from tank.
 - Turn off aerator.
 - If high groundwater is present, fill with clean water.
 - If no groundwater is present, leave tank empty.

UNDER NO CIRCUMSTANCES SHOULD THE AERATOR BE TURNED OFF FOR MORE THAN A FEW DAYS WITHOUT REMOVING TANK CONTENTS.

Figure 1

ECOPOD Edge500 installed in the Infiltrator CM-1060 tank

A	PRETREATMENT CHAMBER
B	REACTOR CHAMBER
C	CLARIFICATION ZONE
D	ECOPOD REACTOR
E	INLET
F	RECIRCULATION LINE
G	ACCESS
H*	CONTROL PANEL
I*	AERATOR
J	VENT
K	EFFLUENT SAMPLE PORT**
L	OUTLET

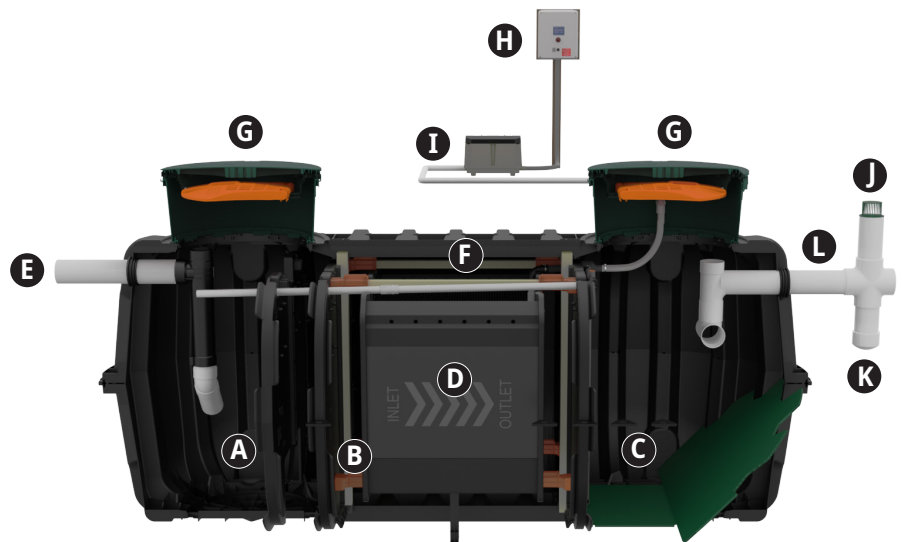

*More than one control panel model and aerator model has been approved for use with the ECOPOD-Edge systems. Please contact Infiltrator if you have any questions.
 ** Alternate vent and sample port options are shown below.

Sample Procedures (If Applicable):

1. Prior to collecting samples, contact the certified testing laboratory to request the appropriate sample containers.
2. Collect, handle, store, and transport samples as specified by the testing laboratory requirements and procedures.
3. Samples should be taken from the effluent discharge line or from the effluent pump tank or after the disinfection device.
4. Induce flow through the system by turning water faucets on, flushing toilets or by inserting a garden hose fitted with a backflow prevention device inserted into the inlet tee or access riser positioned upstream of the reactor. If a garden hose is used, ensure the end of the hose is not submerged in the wastewater. Allow the water to run for a minimum of four minutes before taking the sample. This will allow any solids to be flushed out that might have accumulated in the discharge pipe. Please see Figure 1 for reference.
5. Insert sample container to collect only effluent that is flowing over the cascading edge.

If these methods cannot be used or a sample port is not accessible, please contact Infiltrator Water Technologies for additional information.

Alternative vent and sample port options.

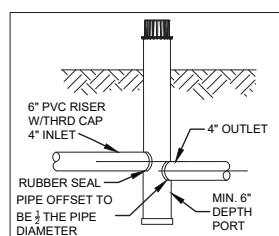
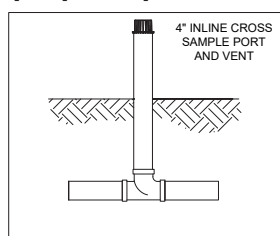
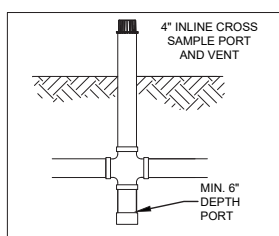

Vent Through Riser

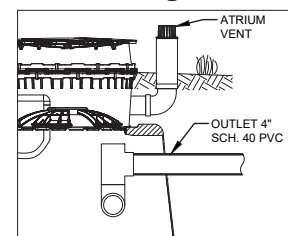

THIS CONFIGURATION CAN NOT BE USED WITH 6 INCH RISERS.

INSTALLATION INSTRUCTIONS

ONLY FOR USE BY CERTIFIED, LICENSED INSTALLERS

Tools Required: Cordless drill, screwdriver set, 5" hole saw, 1 3/4" hole saw, soapy water, PVC cement, hose and water access, level.

1. Tank Delivery and Handling

Care must be taken offloading and unpacking tank and components. Care must be taken not to damage tank and components with forklift or any other offloading device. Check for damaged tank and components that may have occurred in transportation and notify factory or distributor within 24 hours of delivery.

Serial Number Label Application Instructions

1. Locate the serial number pouch, which may be attached in one of the following positions: (a) on the top of the tank near the lid; (b) at the back of the lid; or (c) on top of the outlet port.
2. Remove stamped label from pouch.
3. Attach the label inside of control panel door.



2. Set and Backfill Tank

Excavate and set tank as recommended by the tank per reference the Infiltrator IM- and CM-Series Tank Installation Instructions. Prior to backfill, install tank access risers as needed. It is very important to follow all backfill and compaction procedures required by the tank manufacturer.

Note: It is recommended that any excavation be roped off with caution tape for jobsite safety.

3. Plumb Tank Inlets and Outlets

Plumb and solvent weld all inlet and outlet tees. When glued, the inlet T will be positioned at a 90-degree angle to the inletting pipe and face the opposite direction of the recirculation pipe.

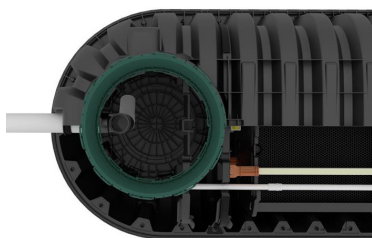

Optional Installation

Method: the inlet pipe to the tank can enter through the side port opposite the Edge recirculation pipe. The inlet tee will need to be reconfigured to ensure the discharge is directed back towards the side of the tank opposite the recirculation pipe

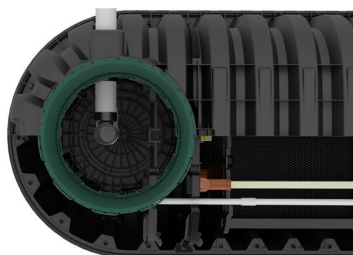

4. Plumb Air Distribution System

The air distribution system is preassembled with 30" of flex PVC. The air distribution line may be cut if needed with its length and orientation dependent upon site conditions. Drill a hole with a 1 3/4" hole saw in the riser to accommodate the 1" grommet for the airline, accounting for where the aerator will be located. Run the 1" schedule 40 PVC airline through the grommet and solvent weld to the 1-inch flex piping using either a coupling or angled fitting. See images below.

Note: Removal of flex piping from air distribution assembly will void warranty.

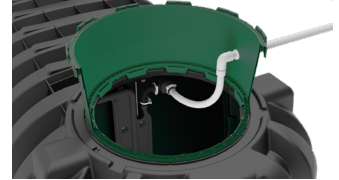

Note: During the installation of the air distribution line, use caution to ensure no dirt nor debris enters the line. This can plug the line and create issues with system performance.

5. Backfill Treatment System

It is very important to follow all backfill and compaction procedures required by the tank manufacturer. Backfill the treatment system in lifts of no more than 12 inches. Compact each lift up to the treatment system inlet and outlet pipes. Reference the Infiltrator IM- and CM-Series Tank Installation Instructions.

6. Fill Tank with Clean Water

Begin filling the reactor tank or chamber with clean water while the air distribution and control panel assembly are completed. Continue filling the tank or chamber until water level reaches the outlet tee. It will take several hours using residential water service.

7. Aerator Placement and Connection*

Do not install the aerator(s) in a low-lying area where water may accumulate and protected from flooding and ant infestation. The aerator should be installed near the control panel, installed above grade, and within 100 feet of the ECOPOD-Edge. The aerator can be installed outdoors or in a clean, dry, well-ventilated area, such as a tool room, garage, etc. A minimum of 12 inches of ground cover is recommended over the air supply piping. At the aerator, connect the 1-inch galvanized male adapter to the aerator using the supplied hose and clamps. Next connect the aerator to the air supply lines using the 1-inch PVC adapter, solvent weld the adapter to the 1" schedule 40 air supply line. See picture below.

Follow all electrical code requirements when connecting to the control panel. See Section 9 of this manual for additional information.



* **NOTE:** This section applies to the standard LW-250 blower. If your system utilizes a TKO-250, refer to the TKO-250 Addendum for additional installation and maintenance details.

INSTALLATION (CONT.) AND TROUBLESHOOTING GUIDE

8. Install the Vent

Use a 5-inch hole saw to drill a hole in the side of the riser. Insert a 4-inch PVC grommet into the hole. Insert 4-inch Schedule 40 PVC through the grommet. Solvent weld a 90-degree elbow pointing upward. Insert 4-inch Schedule 40 PVC into the 90-degree elbow and extend above existing grade. Place the Atrium vent onto the 4-inch Schedule 40 PVC for proper ventilation.

Reference to **Figure 1** to alternative vent configuration.

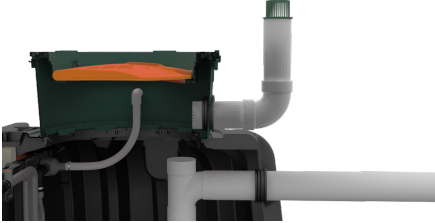

9. Mounting Control Panel

Mount the control panel in a location such that the alarm can be heard and be readily observed. The control panel must be connected to a 120V / 20-amp maximum electrical source equipped with a ground fault interrupter (GFI) circuit breaker. Install a power disconnect switch to the panel that is operable and available to a maintenance provider. The control panel must be grounded. Connect the source ground wire to the ground location in the panel. All electrical work shall be done according to NEC and local code requirements.

1. Attach control panel to a suitable mounting surface.
Use appropriate screws for all four mounting holes on the back of the enclosure.
2. The control panel contains a fuse or circuit breaker for the aerator. An electrical malfunction in the aerator, or wiring to the aerator, will cause the fuse or circuit breaker to blow. The control panel also contains a pressure switch and visual and audible alarms. Loss of air pressure caused by aerator system malfunction, or a high-water level in the treatment tank, will cause the alarm to sound and light to illuminate.
3. The control panel is rated for outdoor service. However, do not place it where it can be immersed in rising water or where runoff water such as from a roof will pour onto it. Do not mount it where it is subject to wetting from sprinklers, hoses, etc.
4. Connect conduit. After the control panel is properly mounted, connect conduit and install wiring as shown on drawings bound herein (Schematics).
5. Connect the pressure air tubing to the 1/8-inch barb-fitting in the air piping system. The air tubing should be protected by conduit as shown on the drawing.

System Startup

Ensure breaker to the Aerator is open.
Provide power to the control panel. Provide clean water to the tank. Once the tank water level reaches the outlet in the treatment tank, close breaker to the Aerator.
Aerator should start.

See additional steps below.

1. Set the high-level pressure switch. To set the high-level pressure switch that detects high water level in the unit bring the tank to operating water level with aerator turned on. Using properly sized screwdriver turn high level alarm adjustment screw clockwise until alarm occurs. Then turn the screw counterclockwise until alarm stops.
2. Remove the cover for the riser on the inlet side of the tank. Check the recirculation line to confirm flow is coming from the line.
3. Check air piping joints for leakage using a soapy water solution. Repair if necessary and then carefully backfill air distribution piping and tanks.
4. Finish grade the site. Divert surface water away from the system and install or plant ground cover to prevent erosion.
5. Tank is ready to receive incoming sewage. No special start-up procedures are required. The process is naturally occurring and does not require any special additives.
6. Replace and secure all tank access lids. Close up the enclosure door on control panel and lock if necessary.
7. Spend time with your customer whenever possible. Review operation instructions. Be sure that the customer has a manual to keep. This saves valuable time avoiding return visits.

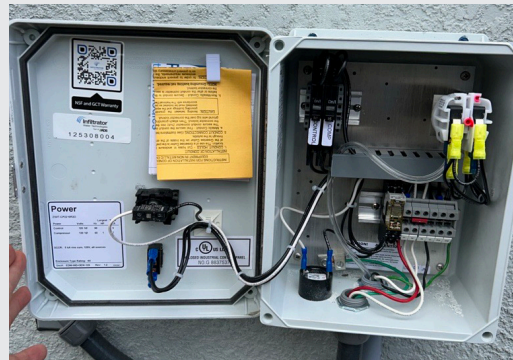

WARNING: CONTROL PANEL CONTAINS HIGH VOLTAGE

TROUBLESHOOTING GUIDE

TROUBLESHOOTING GUIDE

Air Supply Troubleshooting

1. Check to be sure air distribution is working properly. A septic (rotten egg) odor could mean that the system is not getting enough air. If the air system is not working properly, please check the following:
2. Check to be sure the aerator is working.
 - Check the recirculation line on the inlet side of the tank to ensure flow is coming from the line.
 - Check the electrical source.
 - If flow is not coming through the recirculation line, you may need to troubleshoot the Internal Assembly.
 - Wash air filter on aerator. Allow filter to dry completely before reinstalling.
 - If aerator is not running or making an abnormal noise, please contact Infiltrator at 1-800-221-4436.
3. Check to be sure tank is not severely out of level. Air follows a path of least resistance. The pressure differences can be enough to restrict air flow.
4. Check for broken or cracked air lines both outside and inside the tank.
5. Ants will cause the aerator to malfunction. Check to see if there is an ant nest around the aerator.
6. Aerator should be protected from rising water.
7. Always check to see if inlet and outlet lines are correctly installed.

Internal Assembly Troubleshooting

1. Verify that all internal piping and connections are tight and secure.
2. If there is no flow in the recirculation line: The line may be clogged and require cleaning.

To clean the recirculation line:

1. Turn off the aerator completely before proceeding. Warning: Failure to turn off the aerator may cause injury or damage to the system.
2. Use a garden hose to flush the recirculation line on the inlet side of the tank. Direct water through the line to dislodge and remove any solids or buildup.
3. Once flushing is complete, turn the aerator back on.
4. Observe the recirculation line to confirm that flow has resumed.
5. If flow does not resume after cleaning: Contact Infiltrator Water Technologies for further assistance.

Design Overload

1. The system could be hydraulically overloaded (too much water going through the system for the size of the system).
2. The system could be biologically overloaded (too much waste going into the system for its size).
3. Discuss usage with the homeowner.

Improper Installation or Setting

1. Follow the manufacturer's installation procedures very carefully.
2. Where settling is common, approximately 2 inches of a well graded bedding material should be placed and tamped in the bottom of the hole.
3. Proper installation is the first step in preventing callbacks for service problems.

4. Whenever possible, it is important to spend time with the homeowner. Be sure they have an Installation, Operation and Maintenance Manual. A few minutes invested in the beginning will avoid service calls later.

No Harsh Chemicals Should be Put into the System

1. Water in the reactor chamber should be relatively clear in both the reactor and quiescent zones. Blue or gray/blue water indicates heavy use of detergents or other chemicals. If water appears sudsy there is too much detergent being used.
2. Water in the quiescent zone should be clear. Water is discharged into the discharge tee at a minimum of 6 to 8 inches below water surface. You MAY NOT be able to see clear water by looking through the tank. See Sampling section for instructions to collect a sample.
3. Oils and grease should be kept to a minimum. Grease tends to form in white balls.

Troubleshooting Electrical System

1. Aerator does not run:
 - Check main service for power.
 - Check and/or replace fuse with same rating as in control panel.
2. Alarm does not occur when aerator is off:
 - Malfunctioning pressure switch – reset or replace.
 - Malfunctioning light or buzzer – replace.
3. Alarm occurs continuously even when aerator is running:
 - Air leak in main air system or air tubing to pressure switch – repair leak or replace air line.
 - Malfunctioning pressure switch – reset or replace.
 - High water level in tank – inspect for cause.
 - Short in float switch wire or float switches – repair or replace.

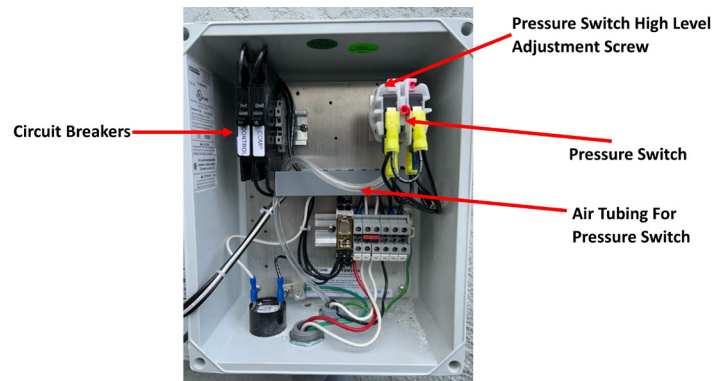

TROUBLESHOOTING GUIDE AND SPECIFICATIONS

Component Replacement Procedure

- Aerator: Follow the same procedure as outlined in the "Installation Instructions".
- Pressure Switch: Turn all power off to the control panel. Remove wired connections and tubing from pressure switch. Remove screws holding the pressure switch to the panel. Reverse procedure to install new pressure switch.
- Audible Alarm: Turn all power off to the control panel. Remove screw attaching alarm to panel as well as connectors. Reverse procedure to install new alarm.
- Alarm Light Holder: Turn all power off to control panel. Remove lock nut securing light holder as well as connectors. Remove lamp holder. Install new light holder with gaskets furnished. Continue with reverse procedure.
- Alarm Light Bulb: Turn all power off to control panel. Remove red light cover. Remove and replace bulb, which is a push-in type. Replace light cover and cover gasket.
- Circuit Breaker: Turn all power off to control panel. Remove fasteners securing circuit breakers as well as connectors. Replace circuit breaker with fasteners and restore power to the control panel.

NOTE: ALL REPLACEMENT PARTS ARE AVAILABLE FROM YOUR LOCAL DISTRIBUTOR

CAUTION: ELECTRICAL SHOCK OR HAZARD MAY OCCUR IF UNIT IS NOT SERVICED PROPERLY. THE MANUFACTURER RECOMMENDS THAT LICENSED ELECTRICIAN BE CALLED WHEN ELECTRICAL PROBLEMS OCCUR.

GENERAL COMMENTS

1. Only factory approved equipment can be used for replacement on individual treatment systems.
2. If the decision is made to pump out a system, be sure to contact a licensed waste hauler.
3. If a chronic problem develops and all items have been checked, contact Infiltrator.
4. Taking pictures of systems when troubleshooting will help document activity in the field.
5. Keep good records.

ECOPOD-Edge Unit Specifications

Treatment Plant	Treatment Capacity (GPD)	Pretreatment/Anoxic Chamber Total Volume (Gal)	Reactor Tank or Chamber Volume (Gal)	Clarification Chamber Total Volume (Gal)
Edge500	500	380	390	341

ECOPOD-Edge Electrical Requirements

Model	Aerator	Motor Full Load Amps	Measured Operating Watts	Electrical Requirements
Edge500	LW-250	3.5	185	115 volt - single phase
Edge500	TKO-250*	4.1	250	120 volt - single phase

* NOTE: Some units may include a TKO-250 blower as an approved alternative. Refer to the TKO-250 Addendum for details.

Setting High Level Pressure Switch

Bring plant to operating water level with the compressor on. Using a properly sized screwdriver, turn high level alarm adjustment screw clockwise until alarm occurs, then turn the screw counter-clockwise until alarm stops.

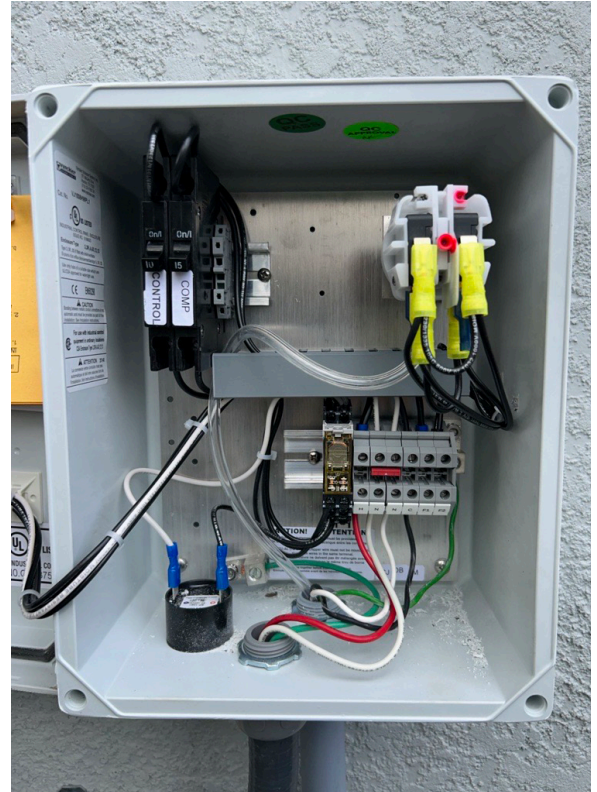
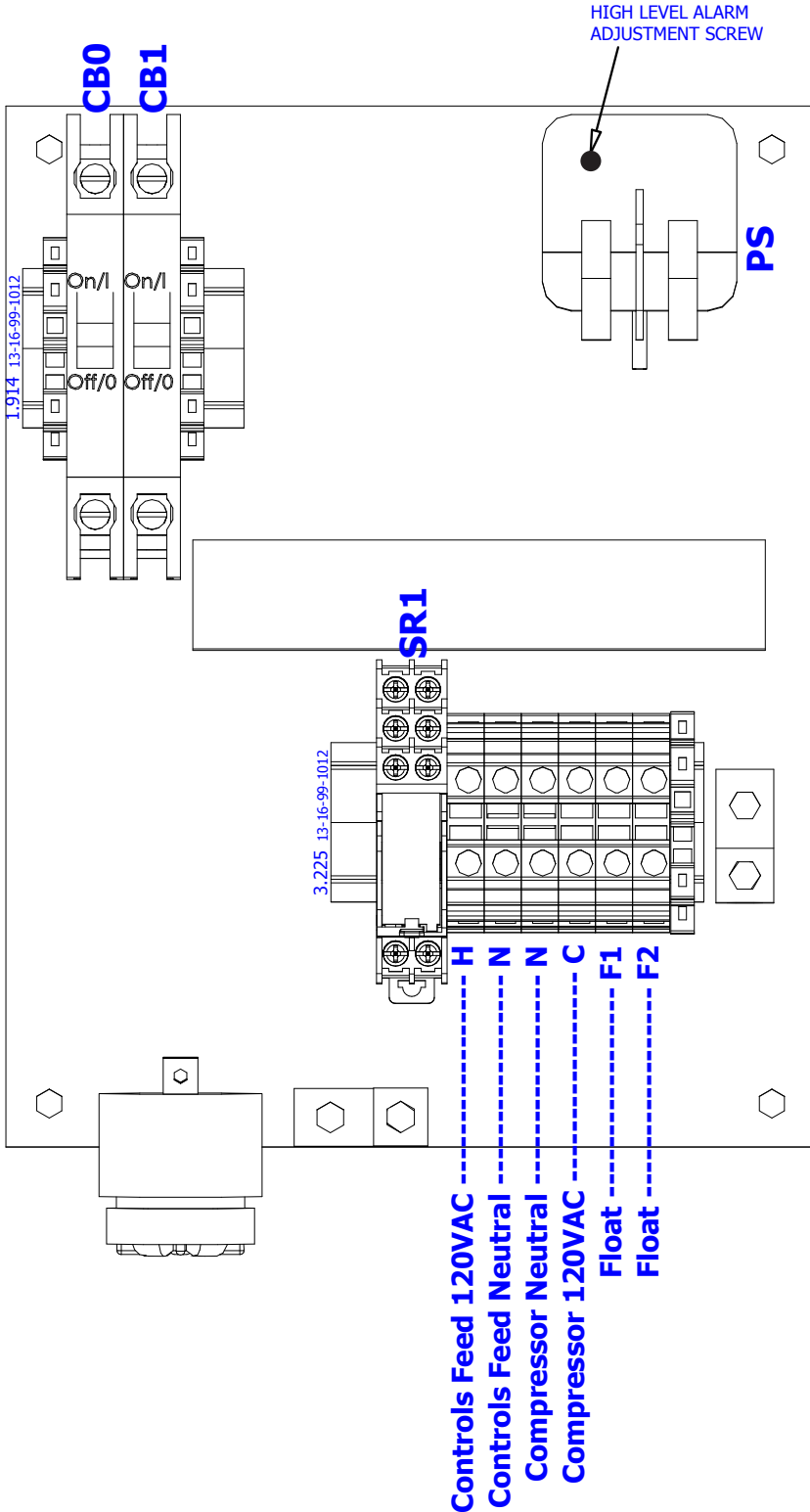

CP2210R2 SCHEMATIC

Main Feed 1
 1X120VAC @60Hz
 Main disconnect provided by others.

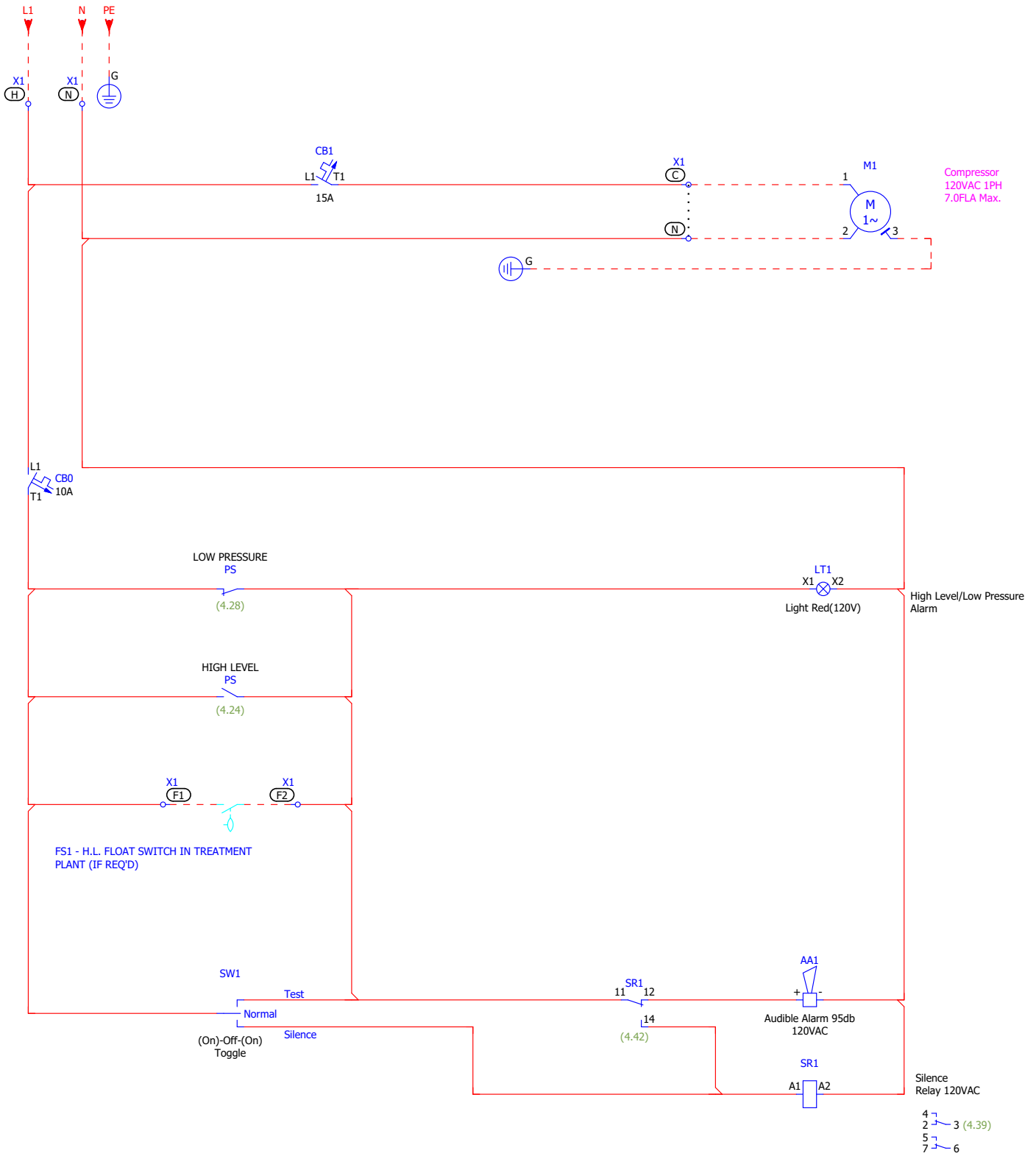



Twin Drive Linear Pump Model LW-250

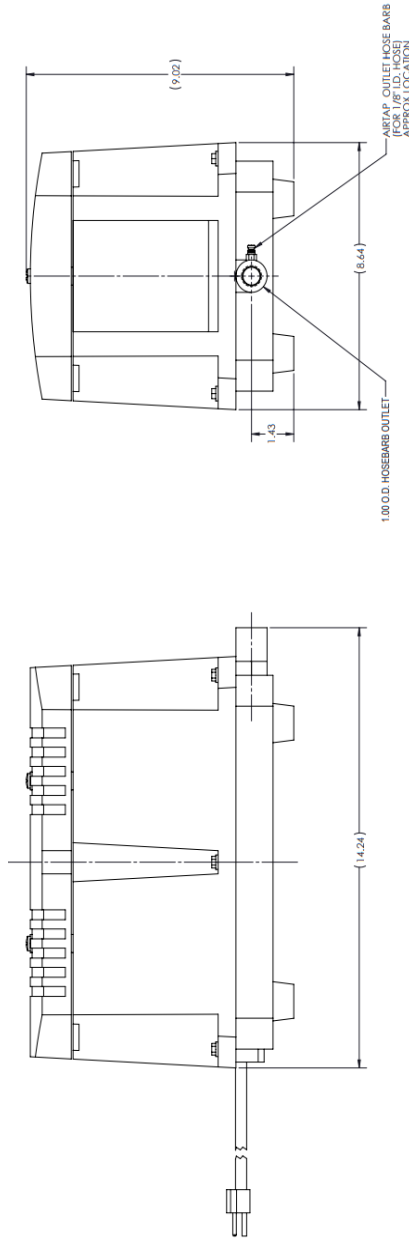

Performance Table

Voltage : 115V Pressure : 2.9 PSI (Pressure Range : 1.45~5.8 PSI)

Pressure(PSI)	1.45	2.9	5.8
Flow (CFM)	10.56	9.15	4.77

Pressure(PSI)	1.45	2.9	5.8
Current (A)	4.37	3.82	2.62

Pressure(PSI)	1.45	2.9	5.8
Input (W)	291	275	173

Pressure(PSI)	1.45	2.9	5.8
Sound Level (dB(A))		42.7	



Model

Spec	Drive Unit	Voltage (V)	Frequency (Hz)	Working Pressure Range (PSI)		Rated Pressure (PSI)	Rated Air Flow (cfm)	Connecting Pipe (in)	Weight (lb)
				Input (W)	Pressure Range				
LW-250	Single Phase	115	60	275	1.45~3.63	2,900	8.83	φ1.00	31.1

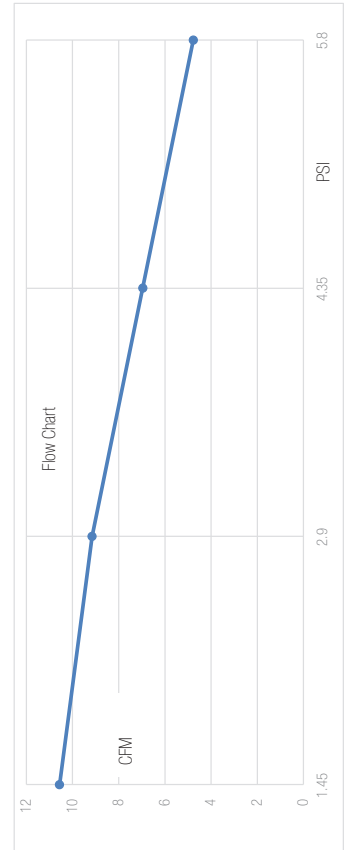

ECOPOD-EDGE SERIES DATA PLATES

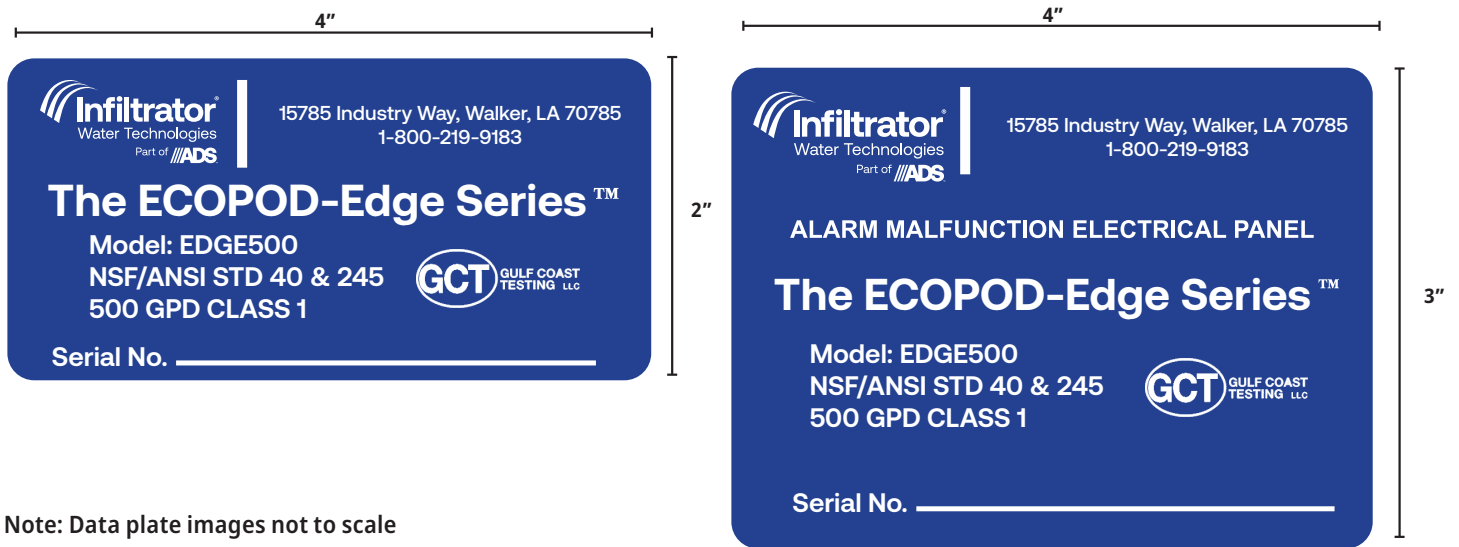

Note: Data plate images not to scale

SERVICE POLICY

INFILTRATOR WATER TECHNOLOGIES INDIVIDUAL MECHANICAL WASTEWATER TREATMENT SYSTEM SERVICE POLICY

INITIAL POLICY:

A two-year initial service policy shall be furnished to the user by the manufacturer or the distributor through the dealer. This policy may be included in the price of the system, provided the state in which the system is being installed has adopted Gulf Coast Testing, LLC Certification Policies for Wastewater Treatment Devices as part of their state rules.

1. **An inspection/service call every six months**, which includes inspection, adjustment, and servicing of the mechanical and electrical component parts as necessary to ensure proper function.
2. An effluent quality inspection every six months consisting of a visual check for color, turbidity, scum overflow, and an examination for odors.
3. If any improper operation is observed that cannot be corrected at that time, the user shall be notified immediately in writing of the conditions and the estimated date of correction. **THIS POLICY DOES NOT INCLUDE PUMPING SLUDGE FROM UNIT IF DEEMED NECESSARY.**

CONTINUING SERVICE POLICY:

An annually renewable service policy affording the same coverage as the Initial Service Policy is available. Consult your dealer for pricing information. The annually renewable service policy should provide the same service checks as the initial Gulf Coast Testing service policy and should be performed annually, or as required by state or local requirements.

PARTS:

Replacement parts or components may be obtained from your local distributor or contact Infiltrator Water Technologies for information.

COMPLAINTS:

In order for Infiltrator Water Technologies to properly address complaints, we require that you put in writing the date and nature of the complaint as detailed as possible. This MUST include the serial number of your system.

Send to: Infiltrator Water Technologies
4 Business Park Road, P.O. Box 768, Old Saybrook, CT 06475-0768

WARRANTY

INFILTRATOR WATER TECHNOLOGIES, LLC (“INFILTRATOR”) INFILTRATOR TWO (2) YEAR ECOPOD® SERIES MATERIALS AND WORKMANSHIP LIMITED WARRANTY

- (a) This limited warranty is extended to the end user of a Infiltrator ECOPOD® Series Advanced Wastewater Treatment Product (the “ECOPOD® Product”). An ECOPOD® Product manufactured by Infiltrator, when installed and operated in accordance with Infiltrator’s installation instructions and local regulation by a licensed installer, is warranted to you: (i) against defective materials and workmanship for two (2) years after installation. Infiltrator will, at its option, (i) repair the defective product or (ii) replace the defective materials. This Warranty does not cover any damage caused by flooding, abuse, unauthorized disassembly, improper wiring or overload protection. This Warranty does not cover any of the house wiring, plumbing, drainage or disposal systems.
- (b) In order to exercise your warranty rights, you must notify Infiltrator in writing at its corporate headquarters in Old Saybrook, Connecticut within fifteen (15) days of the alleged defect. Infiltrator reserves the right to inspect the item to confirm that it is defective.
- (c) YOUR EXCLUSIVE REMEDY WITH RESPECT TO ANY AND ALL LOSSES OR DAMAGES RESULTING FROM ANY CAUSE WHATSOEVER SHALL BE SPECIFIED IN SUBPARAGRAPH (a) ABOVE. INFILTRATOR SHALL IN NO EVENT BE LIABLE FOR ANY CONSEQUENTIAL OR INCIDENTAL DAMAGES OF ANY KIND, HOWEVER OCCASIONED, WHETHER BY NEGLIGENCE OR OTHERWISE. SOME STATES DO NOT ALLOW THE EXCLUSION OR LIMITATION OF INCIDENTAL OR CONSEQUENTIAL DAMAGES, SO THIS LIMITATION OR EXCLUSION MAY NOT APPLY TO YOU. THIS WARRANTY GIVES YOU SPECIFIC LEGAL RIGHTS AND YOU MAY ALSO HAVE OTHER RIGHTS WHICH VARY FROM STATE TO STATE.
- (d) THIS LIMITED WARRANTY IS THE EXCLUSIVE WARRANTY GIVEN BY INFILTRATOR AND SUPERSEDES ANY PRIOR, CONTRARY, ADDITIONAL, OR SUBSEQUENT REPRESENTATIONS, WHETHER ORAL OR WRITTEN. INFILTRATOR DISCLAIMS AND EXCLUDES TO THE GREATEST EXTENT ALLOWED BY LAW ALL OTHER WARRANTIES, WHETHER EXPRESS OR IMPLIED, OR STATUTORY, INCLUDING ANY WARRANTY OF MERCHANTABILITY, FINESSE FOR A PARTICULAR PURPOSE AND ANY IMPLIED WARRANTIES OTHERWISE ARISING FROM COURSE OF DEALING, COURSE OF PERFORMANCE, OR USAGE OF TRADE. NO PERSON (INCLUDING ANY EMPLOYEE, AGENT, DEALER, OR REPRESENTATIVE) IS AUTHORIZED TO MAKE ANY REPRESENTATION OR WARRANTY CONCERNING THIS PRODUCT, EXCEPT TO REFER YOU TO THIS LIMITED WARRANTY. EXCEPT AS EXPRESSLY SET FORTH HEREIN, THIS WARRANTY IS NOT A WARRANTY OF FUTURE PERFORMANCE, BUT ONLY A WARRANTY TO REPAIR OR REPLACE DEFECTIVE COMPONENTS.
- (e) YOU MAY ASSIGN THIS LIMITED WARRANTY TO A SUBSEQUENT PURCHASER OF YOUR HOME.
- (f) NO REPRESENTATIVE OF INFILTRATOR HAS THE AUTHORITY TO CHANGE THIS LIMITED WARRANTY IN ANY MANNER WHATSOEVER, OR TO EXTEND THIS LIMITED WARRANTY BEYOND THE STATED TWO (2) YEAR TERM.
- (g) NO WARRANTY OF ANY KIND IS MADE WITH REGARD TO ANY PRODUCT, COMPONENTS, DEVICES, MEDIA OR TREATMENT UNITS WHICH ARE MANUFACTURED BY OTHERS AND ARE INSTALLED IN CONNECTION WITH THE ECOPOD® PRODUCT. USE OF THESE PRODUCTS ARE AT YOUR OWN RISK.

CONDITIONS AND EXCLUSIONS

There are certain conditions or applications over which Infiltrator has no control. Defects or problems as a result of such conditions or applications are not the responsibility of Infiltrator and are NOT covered under this warranty. They include failure to install the ECOPOD® Product in accordance with instructions or applicable regulatory requirements or guidance and altering the ECOPOD® Product contrary to the installation instructions.

ECOPOD®-EDGE INSTALLATION, OPERATION AND MAINTENANCE MANUAL: EDGE500 ADDENDUM

The ECOPOD® Edge500 Advanced Treatment System is supplied with the LW-250 aerator as standard. Additionally, the FPZ TKO-250 has been approved for use with the Edge500. This addendum provides guidance for the installation and maintenance specific to the TKO-250.

APPROVED ALTERNATIVE AERATOR

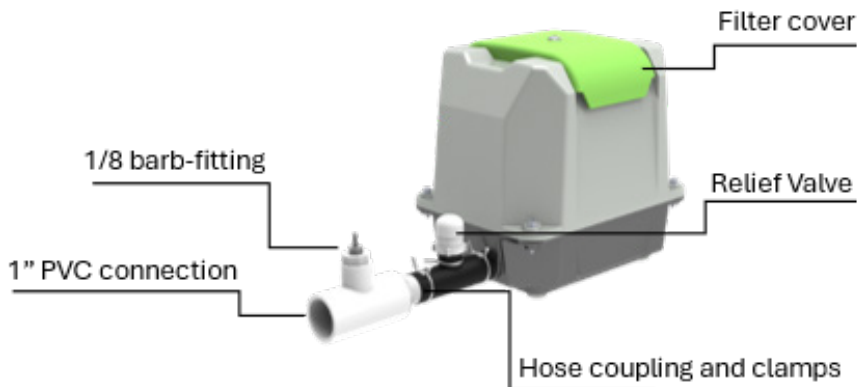

Model: TKO-250

Rated Pressure: 2.9 PSI
Airflow: 8.8 CFM (250 LPM)
Power Consumption: 250 Watts
Voltage: 120V AC / 60 Hz
Outlet Diameter: 1.0 inch (26 mm)
Sound Level: 48 dB(A)

Figure 1: TKO-250

INSTALLATION INSTRUCTIONS

Follow the existing Installation Instructions Section 7. Aerator Placement and Connection from the ECOPOD®-Edge IOM Manual with the following specific notes:

- At the aerator, connect the 1-inch PVC tee to the aerator using the supplied hose and clamps. (shown on Figure 1). Next, solvent weld the 1" PVC tee to the 1" schedule 40 air supply line.
- Connect the pressure air tubing coming from the Control Panel to the 1/8-inch barb-fitting (shown on Figure 1) in the air piping system. The air tubing should be protected by conduit.
- Ensure a minimum of 12 inches of ground cover over the air supply piping.
- See ECOPOD®-Edge IOM Manual for details on how to wire blower to Control Panel's terminals

MAINTENANCE PROCEDURES

- Inspect the air filter every 3-6 months. Clean the filter following these steps:
 - o Undo the truss head screw and remove the filter cover by pulling off in the direction shown (see Figure 2)
 - o Remove the filter and clean it by gently rubbing with a mild, neutral detergent. Rinse thoroughly with clean water, allow it to dry completely before reinstalling it.
 - o Reassemble the filter back in place and secure the filter cover with truss head screw.

WARRANTY AND COMPLIANCE

Use of the TKO-250 is covered under the standard ECOPOD-Edge system warranty when properly installed and maintained. For technical support, contact Infiltrator Water Technologies at (800) 221-4436 or info@infiltratorwater.com.



TKO-150-500

Technical Data		Voltage AC	Frequency HZ	Outlet Diameter Inch / mm	Airflow*		Power* (Watts)	Sound dB(A)**	Rated Pressure (PSI)	Max Pressure (PSI)	Net Weight	
Model	CFM				LPM	Lbs					kg	
TKO-150	5.3	150	60	1.0 / 26	125	44	2.9	3.6	22	10		
TKO-200	7.1	200	60	1.0 / 26	185	46	2.9	3.6	22	10		
TKO-250	8.8	250	60	1.0 / 26	250	48	2.9	3.6	22	10		
TKO-300	10.6	300	60	1.06 / 27	250	52	2.9	3.6	40	18		
TKO-400	14.1	400	60	1.06 / 27	380	54	2.9	3.6	40	18		
TKO-500	17.7	500	60	1.06 / 27	500	56	2.9	3.6	40	18		

* Airflow and power measured at rated pressure

** Specifications are subject to change without notice

ECOPOD®-EDGE INSTALLATION, OPERATION AND MAINTENANCE MANUAL: EDGE500 ADDENDUM

Performance Curves

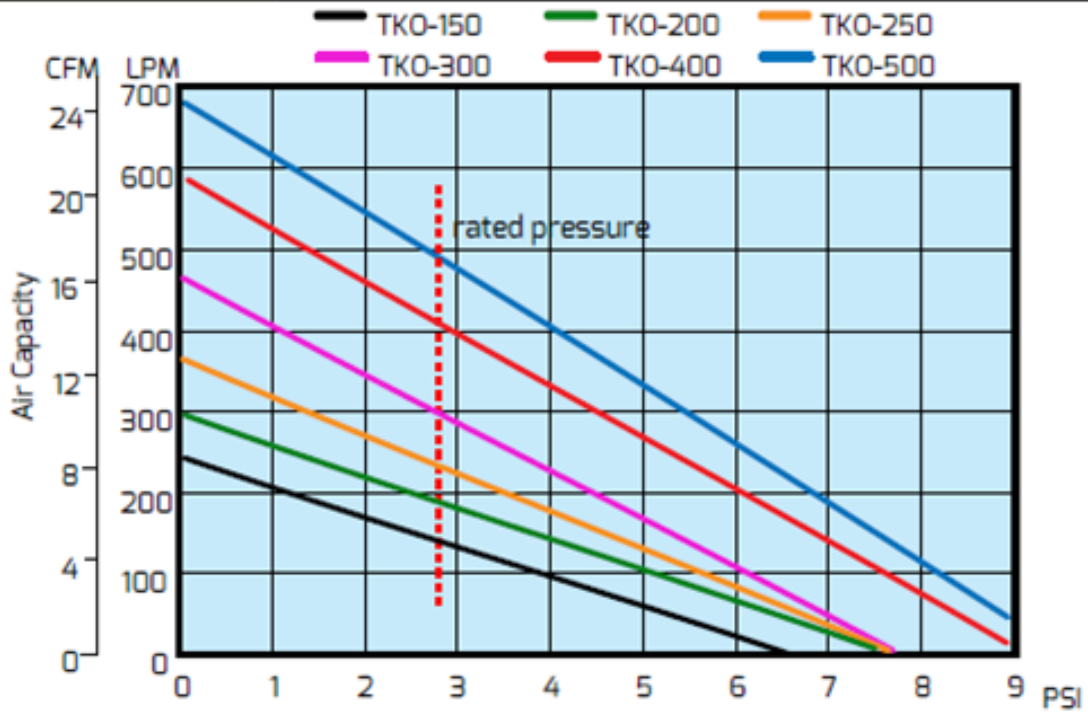

Dimensions Inches (mm)

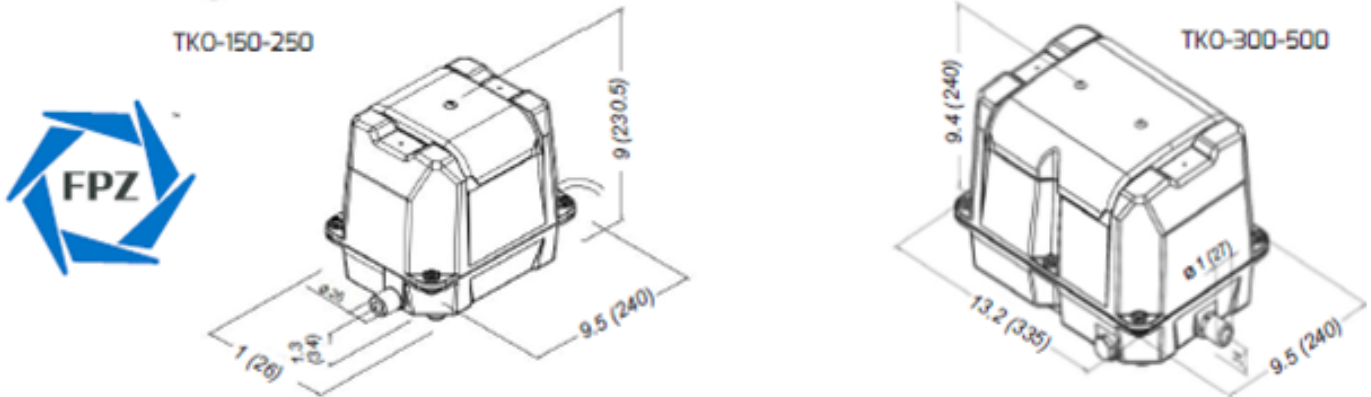

**Contact Infiltrator's Technical Services Department
for assistance at 1-800-221-4436 or info@infiltratorwater.com**

For U.S. Patents information visit www.infiltratorwater.com/patents. Other patents pending. Infiltrator, Quick4 and EZflow are registered trademarks of Infiltrator Water Technologies. Infiltrator Water Technologies is a wholly-owned subsidiary of Advanced Drainage Systems, Inc. (ADS).

© 2026 Infiltrator Water Technologies, LLC. All rights reserved. Printed in U.S.A.

EE03 0426