

**ADVANEDGE INSTALLATION DETAIL
(NO CURB & GUTTER)**

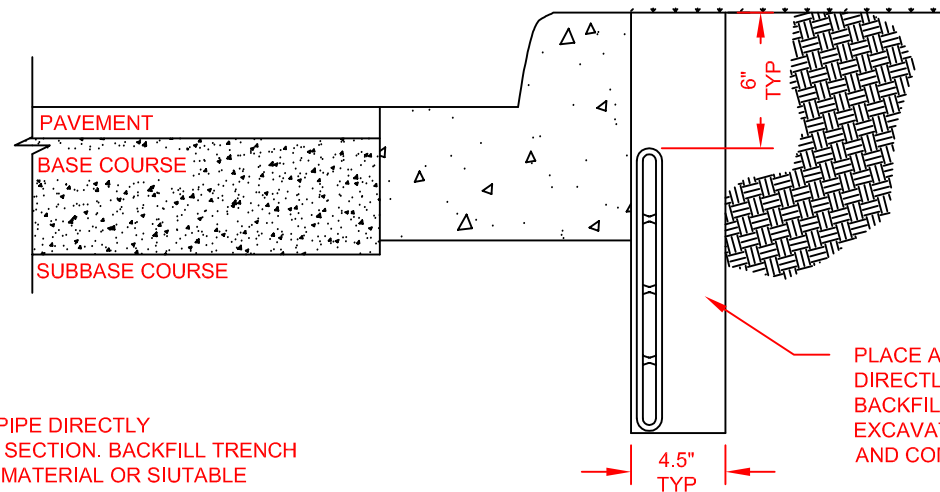

**ADVANEDGE INSTALLATION DETAIL
(CITY STREET W/ CURB & GUTTER)**

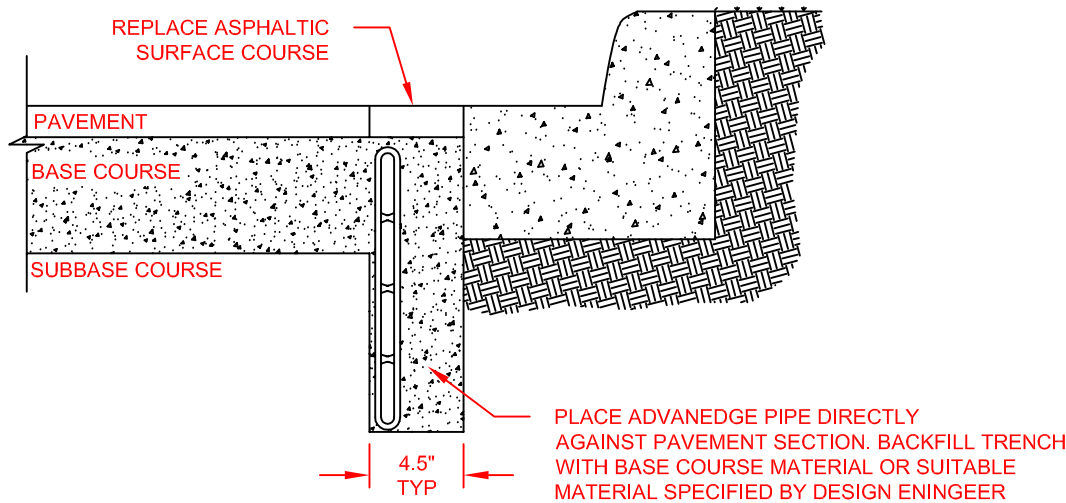

**ADVANEDGE INSTALLATION DETAIL
(CITY STREET W/ CURB & GUTTER)**

© 2016 ADS, INC.

ADVANCED DRAINAGE SYSTEMS, INC. ("ADS") HAS PREPARED THIS DETAIL BASED ON INFORMATION PROVIDED TO ADS. THIS DRAWING IS INTENDED TO DEPICT THE COMPONENTS AS REQUESTED. ADS HAS NOT PERFORMED ANY ENGINEERING OR DESIGN SERVICES FOR THIS PROJECT, NOR HAS ADS INDEPENDENTLY VERIFIED THE INFORMATION SUPPLIED. THE INSTALLATION DETAILS PROVIDED HEREIN ARE GENERAL RECOMMENDATIONS AND ARE NOT SPECIFIC FOR THIS PROJECT. THE DESIGN ENGINEER SHALL REVIEW THESE DETAILS PRIOR TO CONSTRUCTION. IT IS THE DESIGN ENGINEERS RESPONSIBILITY TO ENSURE THE DETAILS PROVIDED HEREIN MEETS OR EXCEEDS THE APPLICABLE NATIONAL, STATE, OR LOCAL REQUIREMENTS AND TO ENSURE THAT THE DETAILS PROVIDED HEREIN ARE ACCEPTABLE FOR THIS PROJECT.

3	REV. DRAWING NAME OR NUMBER	TJR	01/28/16	
REV.	DESCRIPTION	BY	MM/DD/YY	CHK'D

INSTALLATION DETAIL (ADVANEDGE)	
DRAWING NUMBER:	STD-105



4640 TRUEMAN BLVD
HILLIARD, OHIO 43026

DRAWN BY:	KMJ
DATE:	5/6/99
CH'D BY:	
SCALE:	NTS
SHEET	OF