

Technical Note

TN 1.01 Dual Wall HDPE Perforation Patterns

Overview

Perforated pipe plays an integral role in many applications of HDPE pipe. Generally, perforated pipe is used to accelerate the removal of subsurface water in soils or to allow storm water to percolate into the soil. Currently, two classifications of perforations are specified in the AASHTO material specifications for HDPE pipe: Class I, and Class II. The Class II perforation pattern comes standard when perforated pipe is ordered. Class One perforated pipe has limited availability. Please check with a local representative to determine availability. Both classes are explained in more detail in the AASHTO materials specifications (M294 and M252). AASHTO M252 covers pipe diameters 3- through 10-inch (75 - 250 mm) while M294 covers 12-inch through 60-inch (300 - 1500 mm).

Standard Perforation Patterns

AASHTO Class II Perforation

The following terminology for perforations is derived from the applicable AASHTO specification. Differences between the specifications are covered in the table below. Class II perforations shall be located in the outside valleys of the corrugations, be circular and/or slotted and evenly spaced around the circumference and length of the pipe. The perforations shall be located in the outside valleys of the corrugations. The water inlet area shall be no less than 0.945 in²/ft (20 cm²/m) for pipe diameters 4- through 10-inch (100 - 250mm), 1.42 in²/ft (30 cm²/m) for pipe diameters 12- through 18-inch (300 - 450 mm) and 1.89 in²/ft (40 cm²/m) for pipe diameters larger than and equal to 24 inches (600 mm). Table 1 below represents ADS standard perforation patterns for AASHTO Class II.

Nominal I.D.	Perforation Type	Maximum Slot Length or Diameter	Maximum Slot Width	Minimum Inlet Area
4" (100 mm)	Slot	0.875" (22 mm)	0.125" (3 mm)	1.0 in ² /ft (21 cm ² /m)
6" (150 mm)	Slot	0.875" (22 mm)	0.125" (3 mm)	1.0 in ² /ft (21 cm ² /m)
8" (200 mm)	Slot	1.18" (30 mm)	0.125" (3 mm)	1.0 in ² /ft (21 cm ² /m)
10" (250 mm)	Slot	1.18" (30 mm)	0.125" (3 mm)	1.0 in ² /ft (21 cm ² /m)
12" (300 mm)	Circular	0.313" (8 mm)	-	1.5 in ² /ft (32 cm ² /m)
15" (375 mm)	Circular	0.313" (8 mm)	-	1.5 in ² /ft (32 cm ² /m)
18" (450 mm)	Circular	0.313" (8 mm)	-	1.5 in ² /ft (32 cm ² /m)
24" (600 mm)	Circular	0.313" (8 mm)	-	2.0 in ² /ft (42 cm ² /m)
30" (750 mm)	Circular	0.375" (9.5 mm)	-	2.0 in ² /ft (42 cm ² /m)
36" (900 mm)	Circular	0.375" (9.5 mm)	-	2.0 in ² /ft (42 cm ² /m)
42" (1050 mm)	Circular	0.375" (9.5 mm)	-	2.0 in ² /ft (42 cm ² /m)
48" (1200 mm)	Circular	0.375" (9.5 mm)	-	2.0 in ² /ft (42 cm ² /m)
54" (1350 mm)	Circular	0.375" (9.5 mm)	-	2.0 in ² /ft (42 cm ² /m)
60" (1500 mm)	Circular	0.375" (9.5 mm)	-	2.0 in ² /ft (42 cm ² /m)

Figure 1

AASHTO Class II Perforation Patterns

Note: Actual pattern may vary by region, however all patterns meet the AASHTO and ASTM minimum requirements for the open inlet area.

4" – 10"
PIPE DIAMETERS

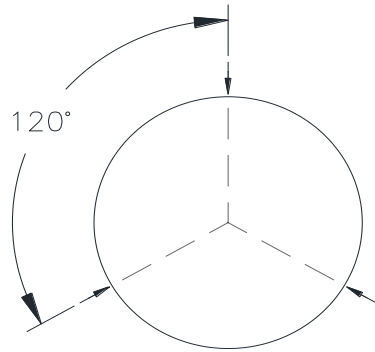

3 AT 120°

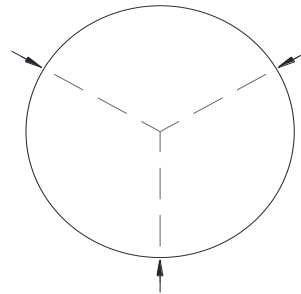

ROTATED
EVERY VALLEY

12" – 18"
PIPE DIAMETERS

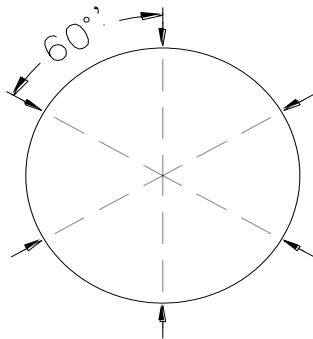

** NUMBER OF HOLES AROUND
CIRCUMFERENCE VARIES BASED ON
DIAMETER AND REGION **

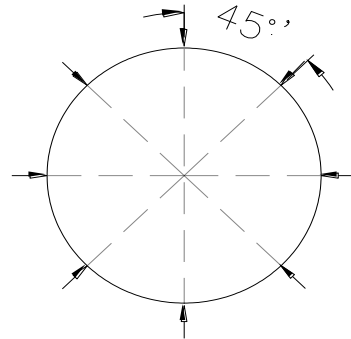

** NUMBER OF HOLES AROUND
CIRCUMFERENCE VARIES BASED ON
DIAMETER AND REGION **

24"
PIPE DIAMETERS

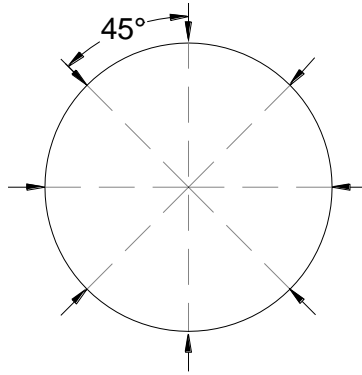

30"
PIPE DIAMETERS

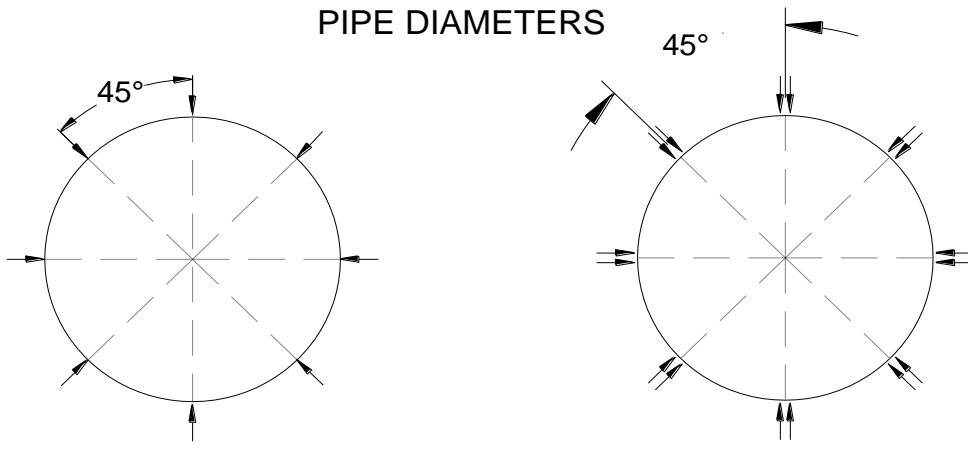

2 AT EVERY 45°

** NUMBER OF HOLES AROUND CIRCUMFERENCE
VARIES BASED ON DIAMETER AND REGION**

36" – 60"
PIPE DIAMETERS

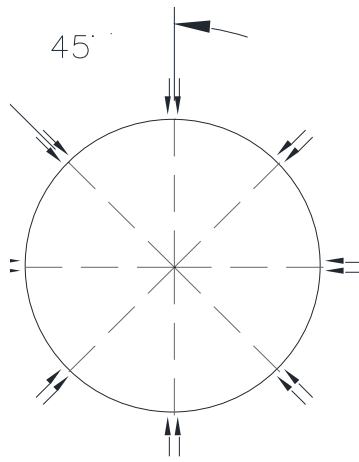

2 AT EVERY 45°



The ADS logo and the Green Stripe are registered trademarks of Advanced Drainage Systems, Inc.
© 2024 Advanced Drainage Systems, Inc. TN 1.01 January 2024

adspipe.com
1-800-821-6710