

DUAL WALL FABRICATED REDUCING WYES
60"×12" - 60"×24" DIAMETER

PART #	PIPE SIZE	A	B	C	JOINT
6084AN	60 x 12 in (1500 x 300 mm)	72.0 in (1829 mm)	64.2 in (1630 mm)	69.2 in (1756 mm)	*
6084AN65B	60 x 12 in (1500 x 300 mm)	60.0 in (1524 mm)	62.2 in (1581 mm)	63.2 in (1604 mm)	WT
6085AN	60 x 15 in (1500 x 375 mm)	78.0 in (1981 mm)	70.2 in (1783 mm)	72.2 in (1833 mm)	*
6085AN65	60 x 15 in (1500 x 375 mm)	66.0 in (1676 mm)	67.6 in (1717 mm)	66.2 in (1680 mm)	WT
6086AN	60 x 18 in (1500 x 450 mm)	78.0 in (1981 mm)	71.0 in (1803 mm)	72.2 in (1833 mm)	*
6086AN65B	60 x 18 in (1500 x 450 mm)	66.0 in (1676 mm)	68.3 in (1735 mm)	66.2 in (1680 mm)	WT
6087AN	60 x 24 in (1500 x 600 mm)	90.0 in (2286 mm)	75.2 in (1911 mm)	78.2 in (1985 mm)	*
6087AN65B	60 x 24 in (1500 x 600 mm)	78.0 in (1981 mm)	72.1 in (1831 mm)	72.2 in (1833 mm)	WT

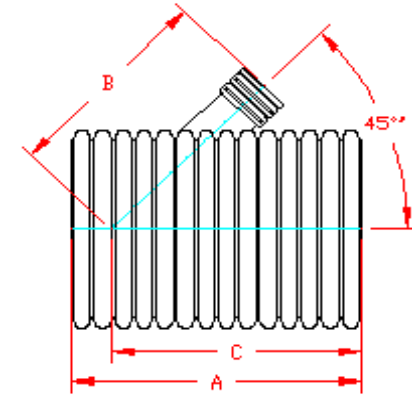

PLAIN END

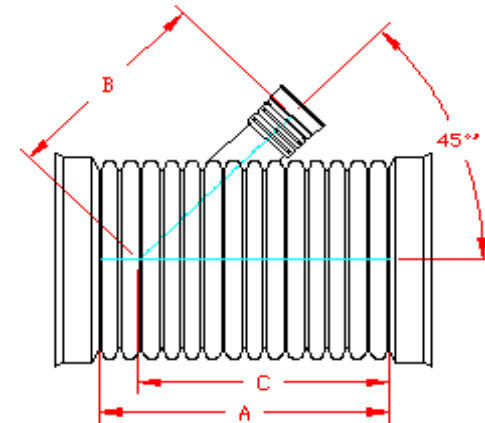

WT (INCLUDES 3 GASKETS)

* = PLAIN END
 ST = SOIL TIGHT
 WT = WATER TIGHT

NOTE: ALL FITTINGS DIMENSIONS ARE FOR REFERENCE ONLY

© 2023 Advanced Drainage Systems, Inc.

	DRAWING #:	2350A	
	DRAWN BY:	JCB	06.14.06
	APPROVED BY:	JCB	06.26.07
	REVISIONS:	NJP	06.14.07