

EXTERNAL SNAP COUPLER

PART #	PIPE SIZE	A	B
0312AA	3 in (75 mm)	4.0 in (102 mm)	4.0 in (102 mm)
0412AA*	4 in (100 mm)	4.3 in (108 mm)	5.1 in (130 mm)
0512AA	5 in (125 mm)	4.4 in (111 mm)	6.3 in (159 mm)
0612AA	6 in (150 mm)	5.6 in (143 mm)	7.4 in (187 mm)
0812AA	8 in (200 mm)	6.0 in (152 mm)	10.0 in (254 mm)
1012AA	10 in (250 mm)	10.3 in (260 mm)	12.5 in (318 mm)

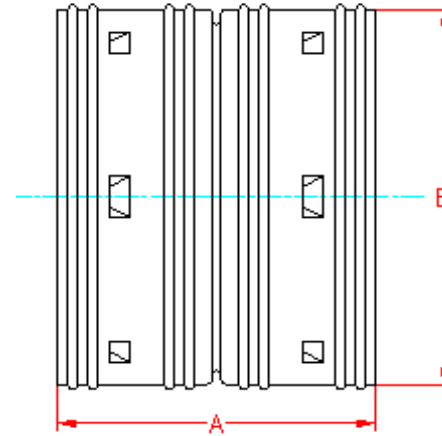

SINGLE WALL SPLIT COUPLER

PART #	PIPE SIZE	A	B
0311AA	3 in (75 mm)	3.0 in (76 mm)	4.0 in (102 mm)
0411AA	4 in (100 mm)	3.8 in (95 mm)	5.1 in (130 mm)
0511AA	5 in (125 mm)	4.0 in (102 mm)	6.3 in (159 mm)
0611AA	6 in (150 mm)	4.0 in (102 mm)	7.4 in (187 mm)
0811AA*	8 in (200 mm)	6.0 in (152 mm)	10.0 in (254 mm)
1011AA*	10 in (150 mm)	5.5 in (140 mm)	12.5 in (318 mm)
1211AA	12 in (300 mm)	8.3 in (210 mm)	15.5 in (394 mm)

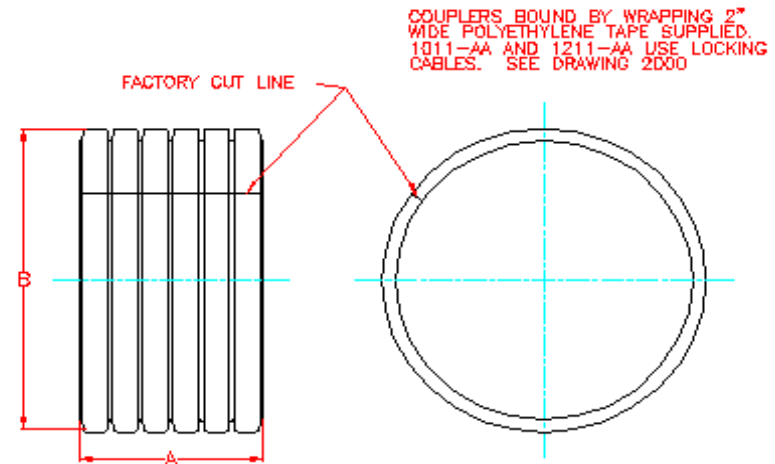

* DENOTES PARTS THAT CAN ALSO BE USED ON DUAL WALL PIPE

NOTE: ALL DIMENSIONS ARE NOMINAL

© 2023 Advanced Drainage Systems, Inc.



DRAWING #:	1000
DRAWN BY:	CRM 09.11.06
APPROVED BY:	JCB 06.22.07
REVISIONS:	NJP 06.12.07

SINGLE WALL SNAP REDUCING COUPLER

PART #	PIPE SIZE	A	B	C
0314AA	4 x 3 in (100 x 75 mm)	4.6 in (118 mm)	5.1 in (130 mm)	4.0 in (102 mm)
0514AA	5 x 4 in (125 x 100 mm)	5.0 in (127 mm)	6.3 in (159 mm)	5.1 in (130 mm)
0614AA	6 x 4 in (150 x 100 mm)	5.8 in (146 mm)	7.4 in (187 mm)	5.1 in (130 mm)
0516AA	6 x 5 in (150 x 125 mm)	5.8 in (147 mm)	7.4 in (187 mm)	6.3 in (159 mm)
0816AA	8 x 6 in (200 x 150 mm)	5.8 in (146 mm)	10.0 in (254 mm)	7.4 in (187 mm)
1018AA	10 x 8 in (250 x 200 mm)	10.0 in (254 mm)	12.5 in (318 mm)	10.0 in (254 mm)
1210AA	12 x 10 in (300 x 250 mm)	11.0 in (279 mm)	15.5 in (394 mm)	12.5 in (318 mm)

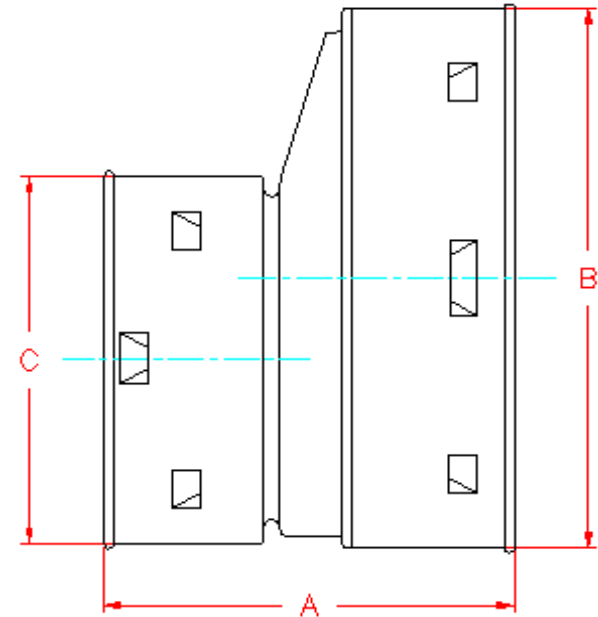

NOTE: ALL DIMENSIONS ARE NOMINAL

© 2023 Advanced Drainage Systems, Inc.

 Advanced Drainage Systems, Inc.	DRAWING #:	1005	
	DRAWN BY:	CRM	09.11.06
	APPROVED BY:	JCB	06.22.07
	REVISIONS:	NJP	06.12.07

INTERNAL REDUCING COUPLER

PART #	PIPE SIZE	A	B
0425AA	5 x 4 in (125 x 100 mm)	8.8 in (222 mm)	5.9 in (149 mm)
0526AA	6 x 5 in (150 x 125 mm)	8.8 in (222 mm)	7.0 in (178 mm)

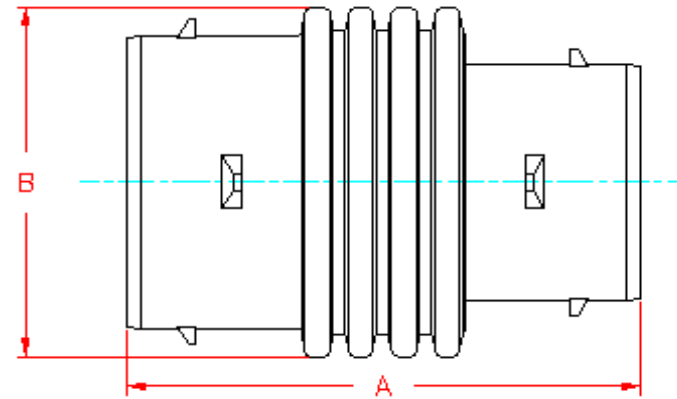

INTERNAL COUPLER

PART #	PIPE SIZE	A	B
0315AA	3 in (75 mm)	6.0 in (152 mm)	3.5 in (89 mm)
0415AA	4 in (100 mm)	8.3 in (210 mm)	4.8 in (121 mm)
0417AA	4 in (100 mm)	6.1 in (156 mm)	4.8 in (121 mm)
0515AA	5 in (125 mm)	8.3 in (210 mm)	5.9 in (149 mm)
0615AA	6 in (150 mm)	8.3 in (210 mm)	7.0 in (178 mm)
0815AA	8 in (200 mm)	11.5 in (292 mm)	9.1 in (232 mm)
1015AA	10 in (250 mm)	12.0 in (305 mm)	9.0 in (229 mm)

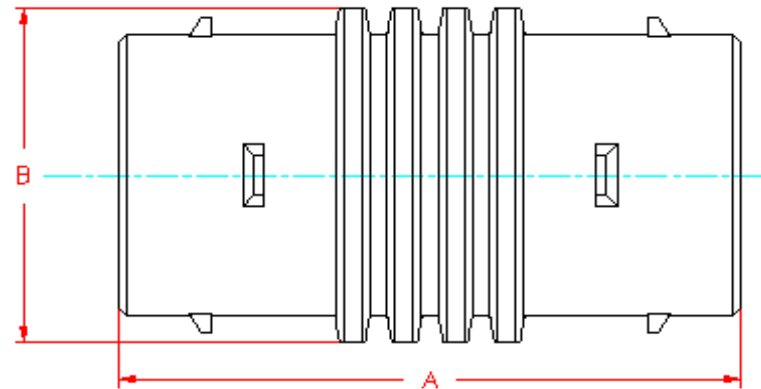

NOTE: ALL DIMENSIONS ARE NOMINAL

© 2023 Advanced Drainage Systems, Inc.



DRAWING #:	1010	
DRAWN BY:	CRM	09.11.06
APPROVED BY:	JCB	06.22.07
REVISIONS:	NJP	06.12.07

90° SNAP ELBOW

PART #	PIPE SIZE	A	B	C
0390AA	3 in (75 mm)	7.4 in (187 mm)	4.0 in (102 mm)	5.4 in (137 mm)
0490AA	4 in (100 mm)	7.9 in (200 mm)	5.1 in (130 mm)	5.3 in (133 mm)

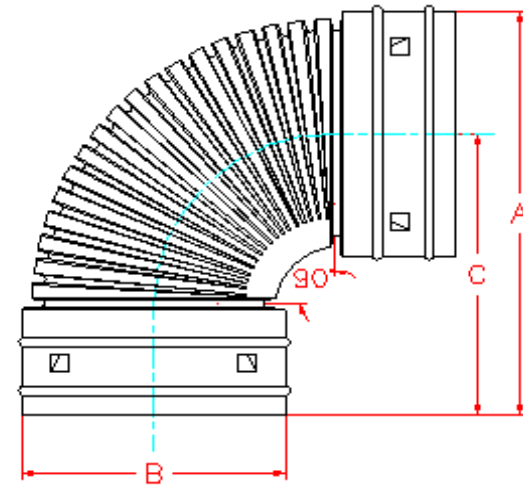

45° SNAP ELBOW

PART #	PIPE SIZE	A	B	C
0445AA	4 in (100 mm)	7.5 in (191 mm)	5.1 in (130 mm)	3.8 in (95 mm)

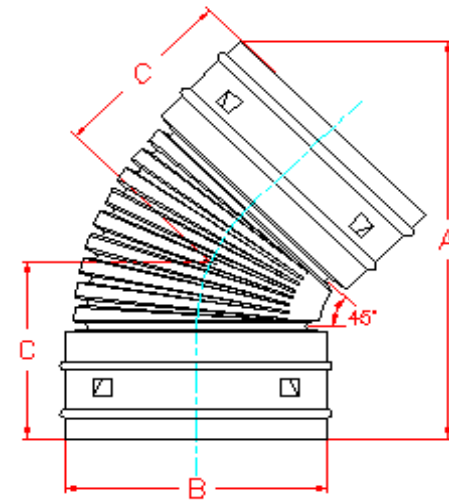

NOTE: ALL DIMENSIONS ARE NOMINAL

© 2023 Advanced Drainage Systems, Inc.



DRAWING #:	1015	
DRAWN BY:	CRM	09.11.06
APPROVED BY:	JCB	06.25.07
REVISIONS:	NJP	06.12.07

SINGLE WALL WYE

PART #	PIPE SIZE	A	B	C	D	E
0322AA	3 in (75 mm)	10.5 in (267 mm)	4.0 in (102 mm)	7.0 in (178 mm)	6.4 in (162 mm)	8.4 in (213 mm)
0422AA	4 in (100 mm)	11.6 in (295 mm)	5.1 in (130 mm)	7.6 in (194 mm)	7.3 in (184 mm)	9.8 in (248 mm)
0522AA	5 in (125 mm)	13.6 in (346 mm)	6.3 in (159 mm)	9.3 in (235 mm)	8.8 in (222 mm)	11.9 in (302 mm)
0622AA	6 in (150 mm)	16.0 in (406 mm)	7.4 in (187 mm)	11.1 in (283 mm)	11.4 in (289 mm)	14.1 in (359 mm)
0822AA	8 in (200 mm)	19.3 in (489 mm)	10.0 in (254 mm)	13.5 in (343 mm)	14.9 in (378 mm)	18.8 in (476 mm)

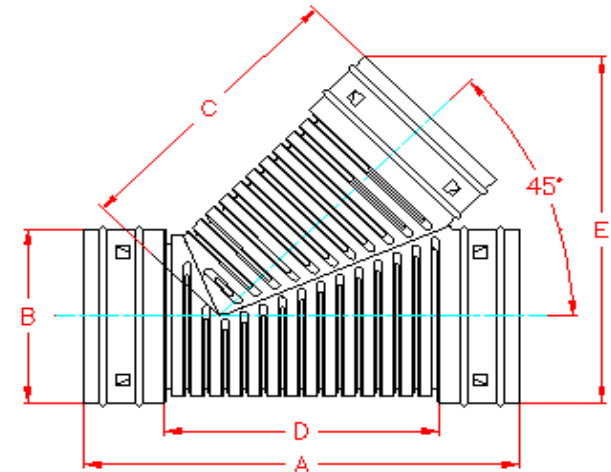

NOTE: ALL DIMENSIONS ARE NOMINAL

© 2023 Advanced Drainage Systems, Inc.

 Advanced Drainage Systems, Inc.	DRAWING #:	1020	
	DRAWN BY:	CRM	09.11.06
	APPROVED BY:	JCB	06.25.07
	REVISIONS:	NJP	06.12.07

SINGLE WALL INTERNAL WYE

PART #	PIPE SIZE	A	B	C	D	E
0321AA	3 in (75 mm)	9.9 in (250 mm)	3.5 in (89 mm)	5.8 in (147 mm)	4.7 in (119 mm)	7.5 in (190 mm)

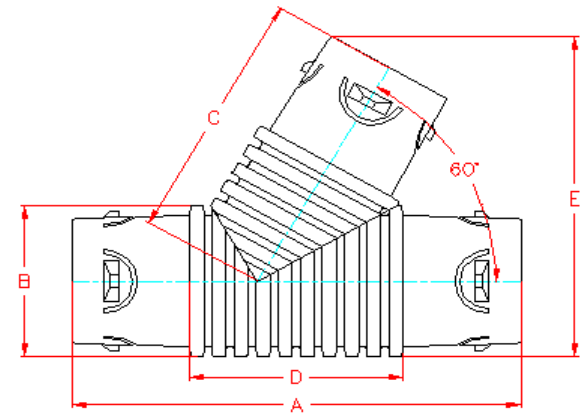

NOTE: ALL DIMENSIONS ARE NOMINAL

© 2023 Advanced Drainage Systems, Inc.

 Advanced Drainage Systems, Inc.	DRAWING #:	1021	
	DRAWN BY:	CRM	09.11.06
	APPROVED BY:	JCB	06.25.07
	REVISIONS:	TJR	10.17.07

BLIND TEE

PART #	PIPE SIZE	A	B	C	D
0341AA	3 in (75 mm)	10.0 in (254 mm)	4.0 in (102 mm)	4.3 in (108 mm)	5.8 in (146 mm)
0441AA	4 in (100 mm)	12.0 in (305 mm)	5.1 in (130 mm)	4.0 in (6 mm)	7.5 in (191 mm)
0541AA	5 in (125 mm)	12.5 in (318 mm)	6.3 in (159 mm)	5.9 in (149 mm)	6.8 in (171 mm)
0641AA	6 in (150 mm)	14.0 in (356 mm)	7.4 in (187 mm)	6.3 in (159 mm)	7.8 in (197 mm)
0841AA	8 in (200 mm)	20.3 in (514 mm)	9.9 in (251 mm)	10.5 in (267 mm)	10.8 in (273 mm)
1041AA	10 in (250 mm)	21.5 in (546 mm)	12.3 in (311 mm)	12.3 in (311 mm)	10.8 in (273 mm)

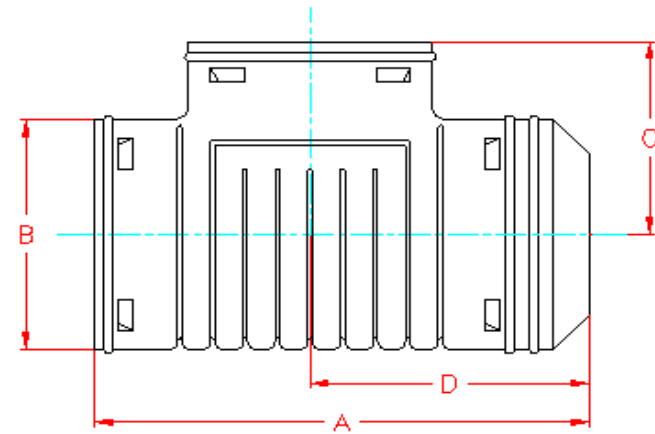

SNAP TEE

PART #	PIPE SIZE	A	B	C	D
0321AA	3 in (75 mm)	8.3 in (210 mm)	4.0 in (102 mm)	4.3 in (108 mm)	4.5 in (114 mm)
0421AA	4 in (100 mm)	9.5 in (241 mm)	5.1 in (130 mm)	4.0 in (102 mm)	5.5 in (140 mm)
0525AA	5 in (125 mm)	10.9 in (276 mm)	6.3 in (159 mm)	5.9 in (149 mm)	5.6 in (143 mm)
0626AA	6 in (150 mm)	12.5 in (318 mm)	7.4 in (187 mm)	6.3 in (159 mm)	7.8 in (197 mm)

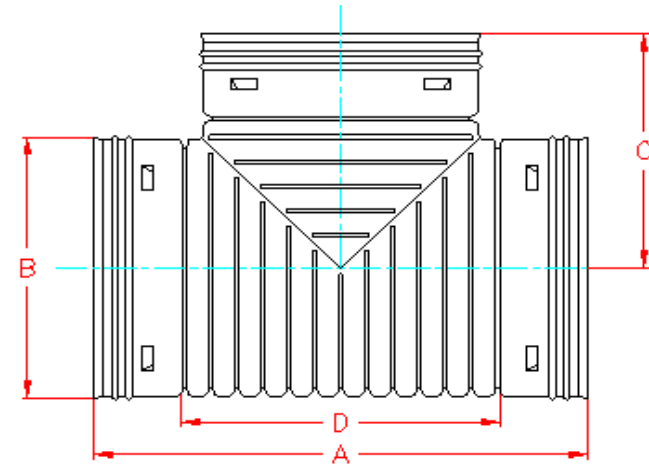

NOTE: ALL DIMENSIONS ARE NOMINAL

© 2023 Advanced Drainage Systems, Inc.

 Advanced Drainage Systems, Inc.	DRAWING #:	1025	
	DRAWN BY:	CRM	09.11.06
	APPROVED BY:	JCB	06.25.07
	REVISIONS:	NJP	06.12.07

INTERNAL SNAP TEE

PART #	PIPE SIZE	A	B	C	D
0321AAIN	3 in (75 mm)	9.1 in (231 mm)	3.5 in (89 mm)	4.6 in (116 mm)	3.7 in (94 mm)

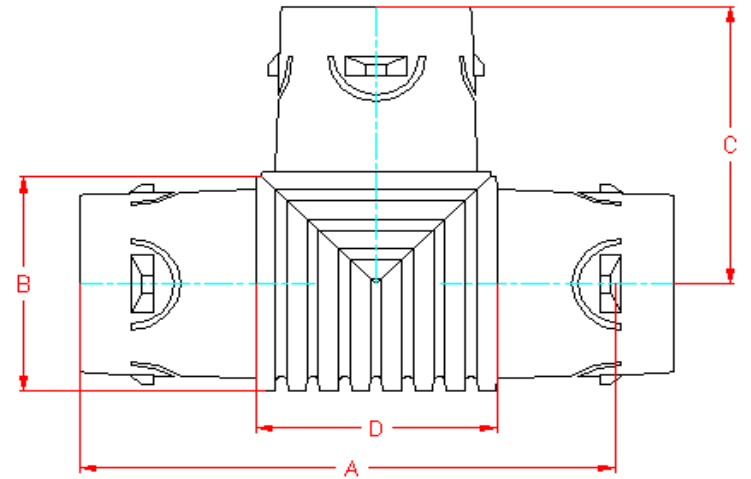

NOTE: ALL DIMENSIONS ARE NOMINAL

© 2023 Advanced Drainage Systems, Inc.

 Advanced Drainage Systems, Inc.	DRAWING #:	1026
	DRAWN BY:	CRM 09.11.06
	APPROVED BY:	JCB 06.25.07
	REVISIONS:	NJP 06.12.07

REDUCING TEE

PART #	PIPE SIZE	A	B	C	D
0523AA	5 x 3 in (125 x 75 mm)	11.5 in (292 mm)	4.0 in (102 mm)	6.0 in (152 mm)	7.0 in (178 mm)
0524AA	5 x 4 in (125 x 100 mm)	10.8 in (273 mm)	5.1 in (130 mm)	6.0 in (6 mm)	5.5 in (140 mm)
0624AA	6 x 4 in (150 x 100 mm)	12.5 in (318 mm)	6.3 in (159 mm)	8.5 in (216 mm)	6.5 in (165 mm)
0625AA	6 x 5 in (150 x 125 mm)	12.5 in (318 mm)	7.4 in (187 mm)	8.5 in (216 mm)	6.5 in (165 mm)

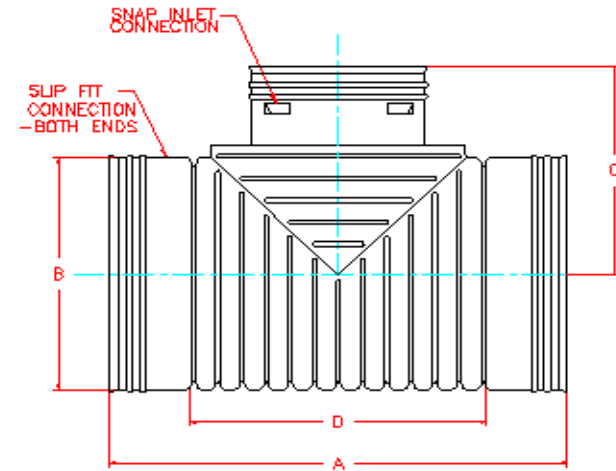

TAP TEE

PART #	PIPE SIZE	A	B	C	D	E
0350AA	3 in (75 mm)	6 & 8 in (150 mm) (200 mm)	4.0 in (102 mm)	3.8 in (95 mm)	2.8 in (70 mm)	2.4 in (60 mm)
0450AA	4 in (100 mm)	6 & 8 in (150 mm) (200 mm)	5.1 in (130 mm)	4.5 in (114 mm)	3.8 in (95 mm)	2.5 in (64 mm)
0410AA	4 in (100 mm)	10 & 12 in (250 mm) (300 mm)	5.1 in (130 mm)	5.3 in (133 mm)	3.8 in (95 mm)	2.8 in (70 mm)

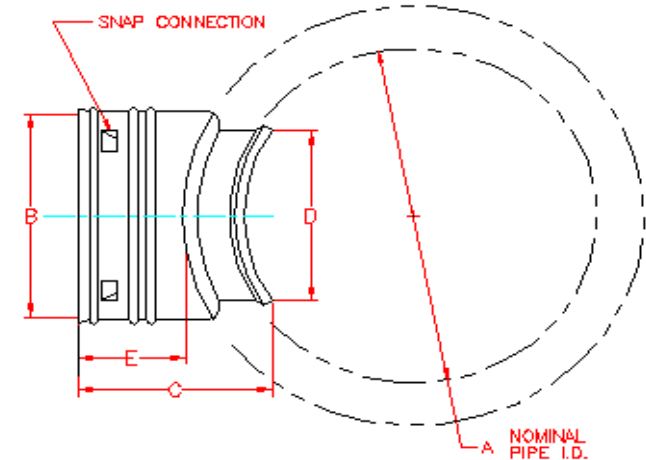

NOTE: ALL DIMENSIONS ARE NOMINAL

© 2023 Advanced Drainage Systems, Inc.



DRAWING #:	1030	
DRAWN BY:	CRM	09.11.06
APPROVED BY:	JCB	06.25.07
REVISIONS:	NJP	06.12.07

MULTIPLE TEE

PART #	PIPE SIZE	A	B	C	D
0644AA	6 in (150 mm)	11.5 in (292 mm)	7.4 in (187 mm)	9.5 in (241 mm)	5.8 in (146 mm)
0844AA	8 in (200 mm)	18.8 in (476 mm)	9.9 in (251 mm)	10.5 in (267 mm)	13.0 in (330 mm)
1044AA	10 in (250 mm)	21.0 in (533 mm)	12.3 in (311 mm)	11.8 in (298 mm)	15.0 in (381 mm)
1244AA	12 in (300 mm)	27.4 in (695 mm)	15.3 in (387 mm)	14.3 in (362 mm)	20.5 in (521 mm)

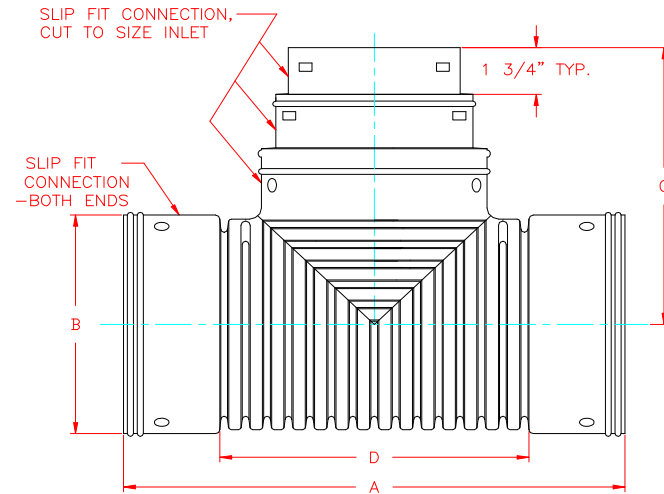

PART #	PIPE SIZE	A	B	C	D
1247AA	12 in (300 mm)	26.1 in (664 mm)	14.7 in (373 mm)	15.0 in (381 mm)	20.3 in (514 mm)
1547AA	15 in (375 mm)	29.6 in (753 mm)	18.0 in (457 mm)	18.4 in (467 mm)	22.3 in (565 mm)
1847AA	18 in (450 mm)	35.4 in (899 mm)	21.6 in (549 mm)	20.5 in (521 mm)	24.8 in (629 mm)

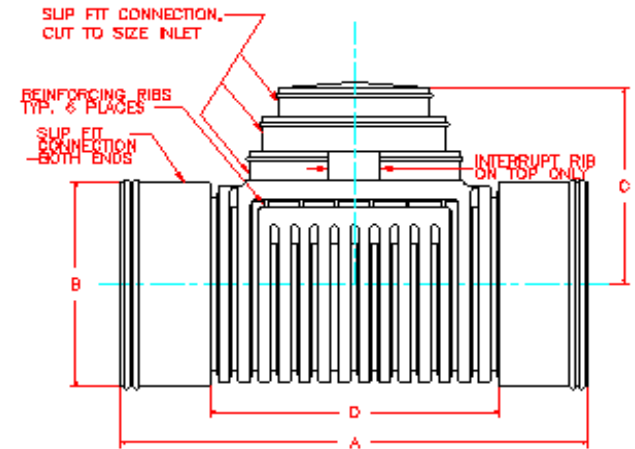

NOTE: ALL DIMENSIONS ARE NOMINAL

© 2023 Advanced Drainage Systems, Inc.

 Advanced Drainage Systems, Inc.	DRAWING #:	1035	
	DRAWN BY:	CRM	09.11.06
	APPROVED BY:	JCB	06.25.07
	REVISIONS:	TJR	09/02/11

MULTIPLE CROSS TEE

PART # 0654

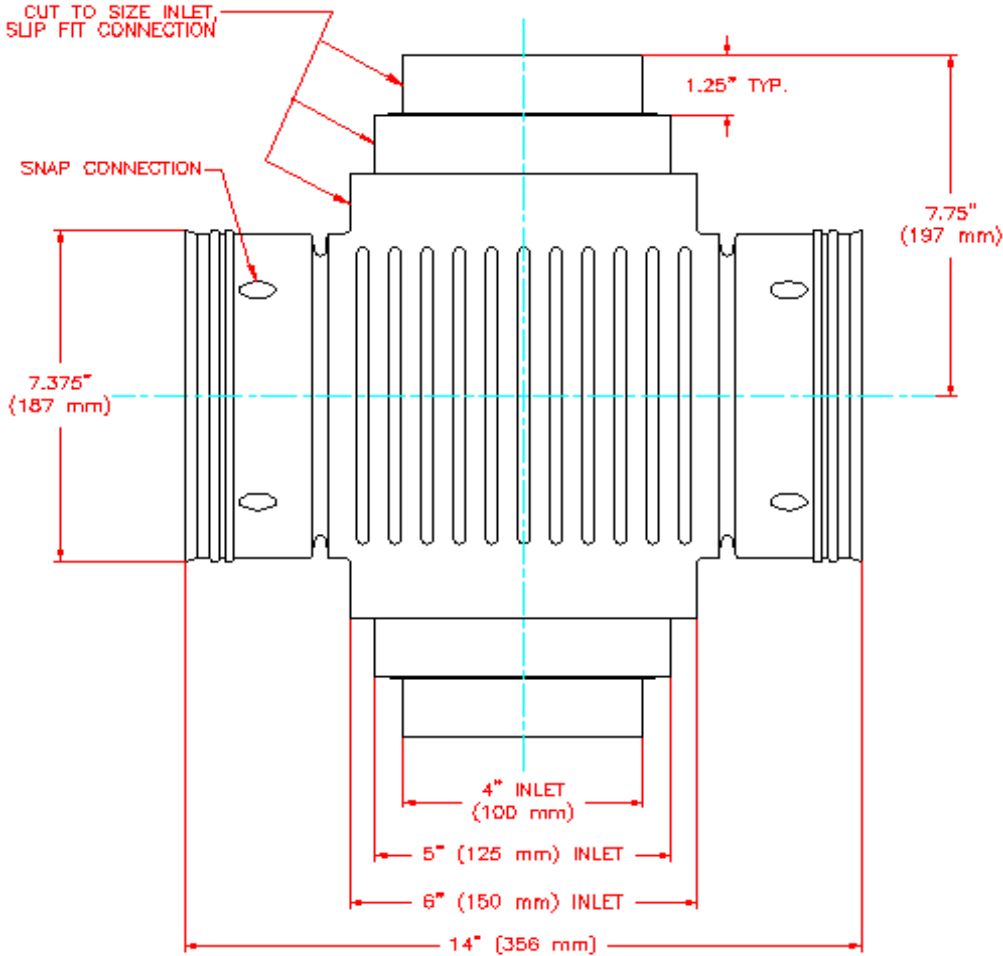

NOTE: ALL DIMENSIONS ARE NOMINAL

© 2023 Advanced Drainage Systems, Inc.

 Advanced Drainage Systems, Inc.	DRAWING #:	1040
	DRAWN BY:	CRM 09.11.06
	APPROVED BY:	JCB 06.25.07
	REVISIONS:	NJP 06.12.07

SNAP END CAP

PART #	PIPE SIZE	A	B
0332AA	3 in (75 mm)	1.9 in (48 mm)	4.0 in (102 mm)
0432AA	4 in (100 mm)	2.8 in (70 mm)	5.1 in (130 mm)
0832AA	8 in (200 mm)	4.3 in (108 mm)	9.9 in (251 mm)
1032AA	10 in (250 mm)	5.0 in (127 mm)	12.5 in (318 mm)

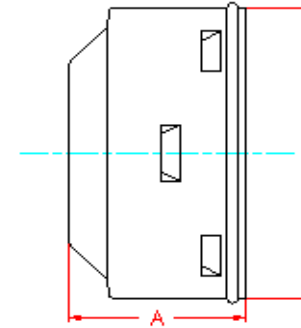

SPLIT END CAP

PART #	PIPE SIZE	A	B
0331AA	3 in (75 mm)	3.3 in (83 mm)	4.0 in (102 mm)
0431AA	4 in (100 mm)	2.8 in (70 mm)	5.1 in (130 mm)
0531AA	5 in (125 mm)	4.3 in (108 mm)	6.3 in (159 mm)
0631AA	6 in (150 mm)	3.3 in (83 mm)	7.4 in (187 mm)

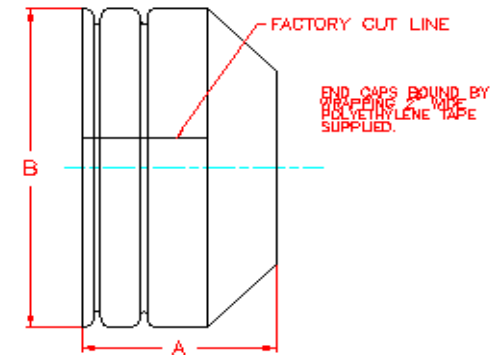

INTERNAL END PLUG

PART #	PIPE SIZE	TYPE
0333AA	3 in (75 mm)	SOLID
0433AA	4 in (100 mm)	SOLID
0533AA	5 in (125 mm)	SOLID
0633AA	6 in (150 mm)	SOLID
0434AA	4 in (100 mm)	PERFORATED

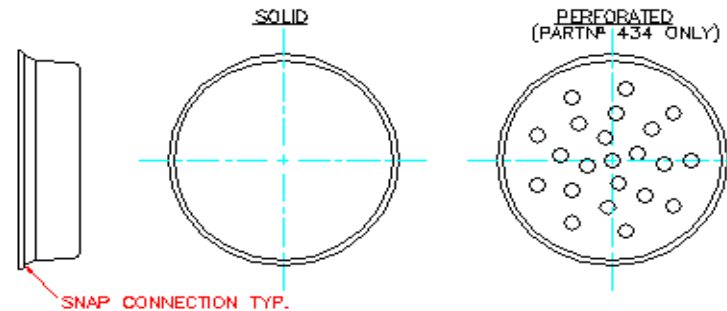

NOTE: ALL DIMENSIONS ARE NOMINAL

© 2023 Advanced Drainage Systems, Inc.



DRAWING #:	1045	
DRAWN BY:	CRM	09.11.06
APPROVED BY:	JCB	06.25.07
REVISIONS:	NJP	06.12.07

INTERNAL SNAP PLUG

PART #	PIPE SIZE	A	B
0332AAIN	3 in (75 mm)	6.0 in (152 mm)	3.5 in (89 mm)

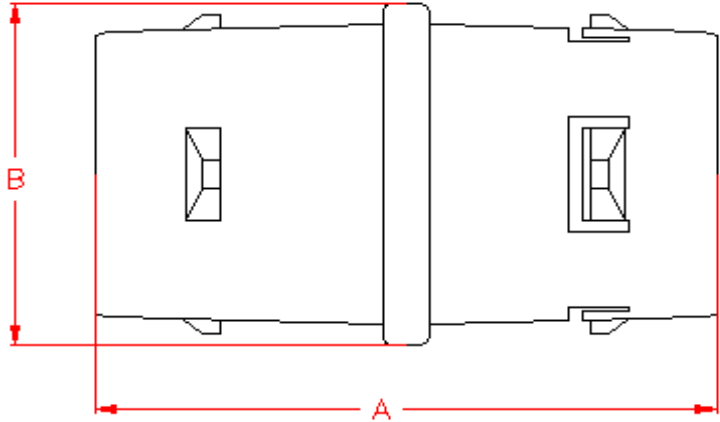

NOTE: ALL DIMENSIONS ARE NOMINAL

© 2023 Advanced Drainage Systems, Inc.

 Advanced Drainage Systems, Inc.	DRAWING #:	1046	
	DRAWN BY:	CRM	09.11.06
	APPROVED BY:	JCB	06.25.07
	REVISIONS:	NJP	06.12.07