

# Drain Basin Installation Guide

Nyloplast drain basins are custom built for each application. Our PVC products are corrosion-resistant compared to concrete or brick and mortar basins. With a faster installation, lower installed cost, and great field and project support teams, Nyloplast is the clear choice for your drainage needs.

## Nyloplast Advantages



### Light Weight

Basins are lighter weight than traditional precast and are safer to handle and install. They also require a much smaller footprint to store the materials on construction sites.



### Small Footprint

Excavation around the structure is the same as the pipe trench width because Nyloplast Basins will allow for size on size pipe to structure connections unlike precast.



### Field flexibility

Nyloplast drain basins are designed for easy adjustment in the field. In the event the elevation is less than expected, the drain basin can be cut down to size. If the elevation is greater than anticipated, riser sections are available up to 6' (1.8 m) in 1' (0.3 m) increments to extend a drain basin.



### Customization

Connecting pipes to Nyloplast structures in the field is made easy with "Add-A-Branch™" and Inserta Tee® taps. Nyloplast will provide water tight connections to numerous types and diameters (4"-24" (100-600 mm)) of pipe in the field if angles or elevation changes occur.

Installation of Nyloplast requires no additional grout work or curing time and install 3-4 times faster than traditional brick and mortar or precast structures.

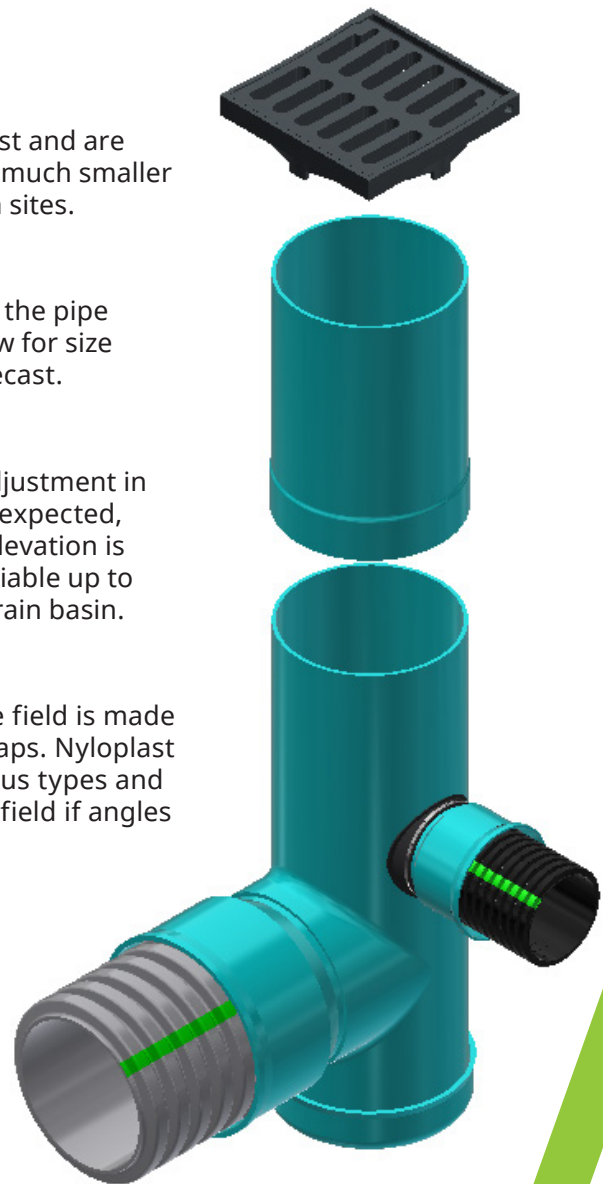

# Step-by-Step Process



**STEP 1:** Excavate Drain Basin location to depth. Provide a stone base. (Width of excavation can be the same width as pipe trench)



**STEP 2:** Set Drain Basin in place and level.



**STEP 3:** Install provided F-477 gasket for HDPE/PP corrugated pipe into last corrugation of the pipe. Lube the gasketed pipe and the inside of the drain basin bell.



**STEP 4:** Backfill the back side of structures and push the pipe home to the seat position. Re-check Drain Basin depth, level and position.



**STEP 5:** Backfill uniformly around structures with class I, II, or III material and compact in lifts according to ASTM D2321.



**STEP 6:** The drain basin body can be cut at the time of the final grade or raised with riser. No brick, stone or concrete block will be required to set the grate to the final grade height.



**NOTE:** For H-20 or heavier load rated installations, set elevation of frame and grate. Then pour a concrete collar around and knife flowable fill under edges to support the frame.

