

Site Development Solutions



Site Development Solutions

Delivering large scale stormwater management solutions

Advanced Drainage Systems offers industry-leading water management products and support to help you meet local regulations and save time/money on your site development projects.

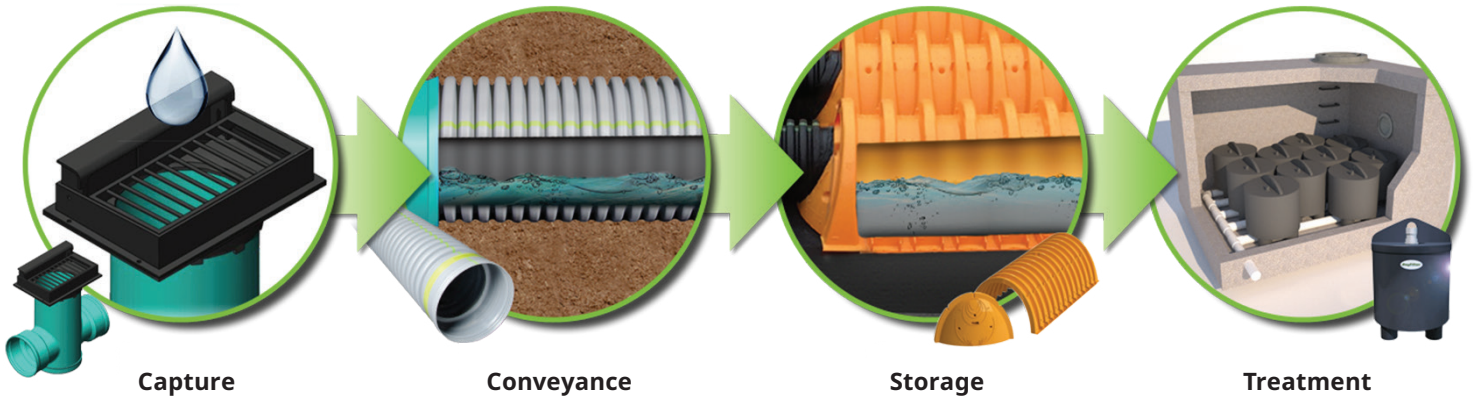

Expansive Footprint



~70

Domestic & International Plants

30+

North American Distribution Centers

80+

Countries Served

~2,000

Distribution Partners



Company-Owned Fleet: 700 Trucks & 1,300 Trailers

Lifecycle of a Raindrop™

Capture



Nyloplast® Structures



Duraslot®
Slotted Drains

Conveyance

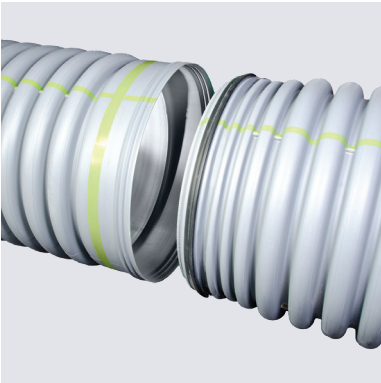

HP Storm Pipe

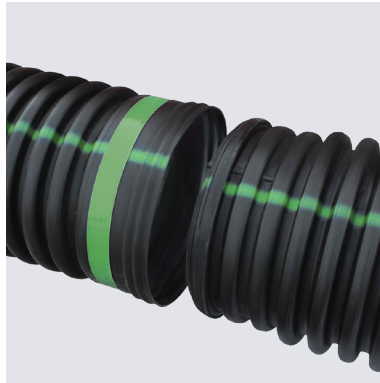

N-12® Dual Wall Pipe

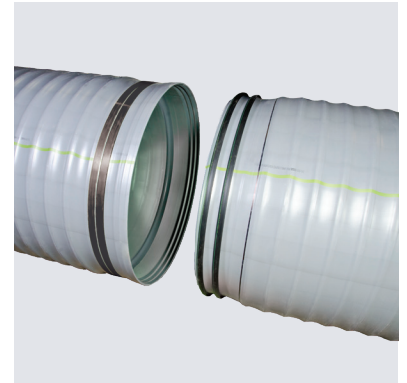

SaniTite® HP Pipe



Singlewall Pipe

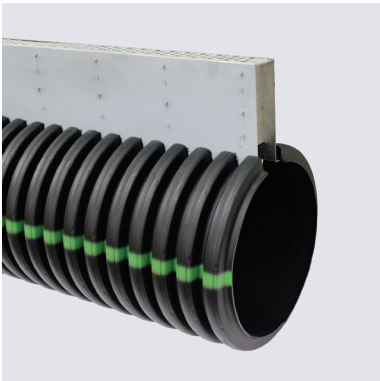

Duraslot
Slotted Drains



Inserta Tee® OneFit™

Storage



StormTech® Chambers

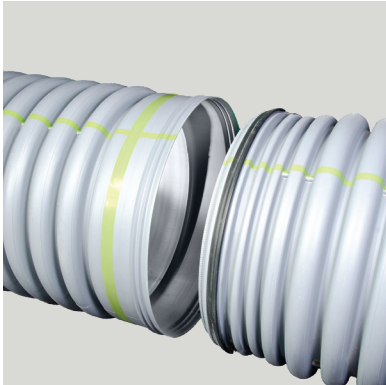

HP Storm Pipe

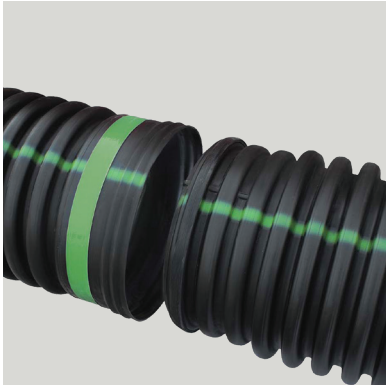

N-12 Dual Wall Pipe

Treatment



Barracuda®
Stormwater Separator

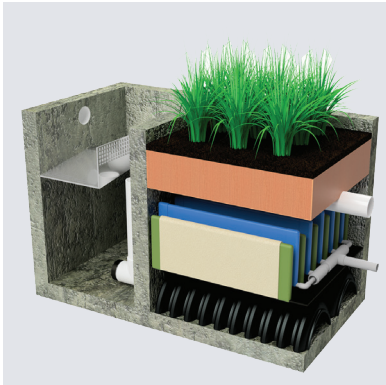

EcoPure BioFilter™



StormTech
Isolator® Row Plus



Inlet Filters

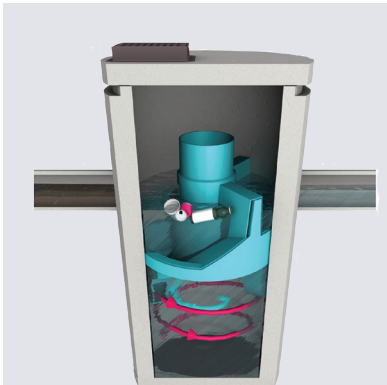

HIL First Defense®

Advanced Drainage Systems' Expertise

ADS provides unparalleled internal support with 40+ engineers and technicians that offer a full continuum of customer service throughout the entire project.

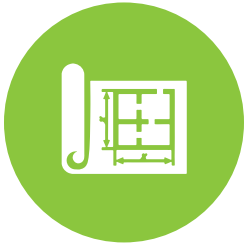

Design layouts



Structural calculations



Unique applications



Plan review



Technical assistance

In addition to the customer service provided by our engineers and technicians, ADS provides a number of other services.

350+ Field Associates

- Regulation expertise
- Contractor training
- Onsite inspections
- Installation training

No Cost Design Services

- Design layouts
- Pre-construction meetings
- Plan reviews
- Onsite inspections

Save Time & Money

- Lightweight products
- Longer laying lengths
- 20% less installed costs
- 3x faster installations



About Advanced Drainage Systems



Ticker: WMS

Since 2014



\$2.9 billion

Fiscal year
2024 revenue



1st

in corrugated
plastic pipe



One of the Largest

plastics recycling companies
in North America



55+ years

Providing solutions



12+ billion

Feet of ADS pipe in
service around the world



350+

Total number of
product solutions



5,500+

Solutions
providers

- ✓ **Industry Leader**
- ✓ **Expansive Footprint**
- ✓ **Comprehensive Product Portfolio**
- ✓ **No Cost Design/Project Management**
- ✓ **Significant Time & Money Savings**

adspipe.ca

800-821-6710

ADS "Terms and Conditions of Sale" are available on the ADS website, www.adspipe.com. The ADS logo, N-12®, SaniTite® HP, Duraslot® and the Green Stripe are registered trademarks of Advanced Drainage Systems, Inc. Inserta Tee® and OneFit™ are registered trademarks of Inserta Fittings, Co. Nyloplast® is a registered trademark of Nyloplast. StormTech® and Isolator® Row are registered trademarks of StormTech, Inc. Barracuda® and EcoPure BioFilter™ are registered trademarks of Baysaver Technologies, Inc. First Defense® is a registered trademark of Hydro International UK Ltd.
© 2024 Advanced Drainage Systems, Inc. #11087_C 08/24 MH

