

## DURASLOT® XL SPECIFICATION

### Scope

This specification describes 6- through 36-inch (150 to 900 mm) Duraslot XL pipe for use in surface drain and conveyance applications.

### Pipe Requirements

Duraslot XL pipe, as manufactured and distributed by ADS, Inc., shall have a smooth interior and annular exterior corrugations with an aluminum slot grate frame mounted longitudinally along the length of the pipe to accept the grate, while maintaining the original pipe diameter.

- 6- through 10-inch (150 to 250 mm) pipe shall meet AASHTO M252, Type S.
- 12- through 36-inch (300 to 900 mm) pipe shall meet AASHTO M294, Type S or ASTM F2306.
- Manning's "n" value for use in design shall be 0.012.

The aluminum slot grate frame shall be manufactured from 0.063" (1.6 mm) tempered commercial aluminum meeting the requirements of ASTM B209, consisting of two parallel plates separated by spacers spanning the slot width. The aluminum slot grate frame shall be coated with a primer to protect the aluminum when installed in concrete. Grates furnished by ADS shall be made of ductile iron with a 4.81-inch (122 mm) width and 19.69-inch (500 mm) length. The grate pattern, open area and load rating will vary based on the chosen design. The flange at the bottom of the aluminum slot grate frame shall be riveted to the pipe with a minimum of two rivets per linear foot.

### Fittings

Duraslot XL fittings shall be modified from fittings which conform to AASHTO M252, AASHTO M294 or ASTM F2306.

### Installation

Installation shall be in accordance with ADS recommended installation instructions. Contact your local ADS representative or visit [www.adspipe.com](http://www.adspipe.com) for a copy of the latest installation guidelines.

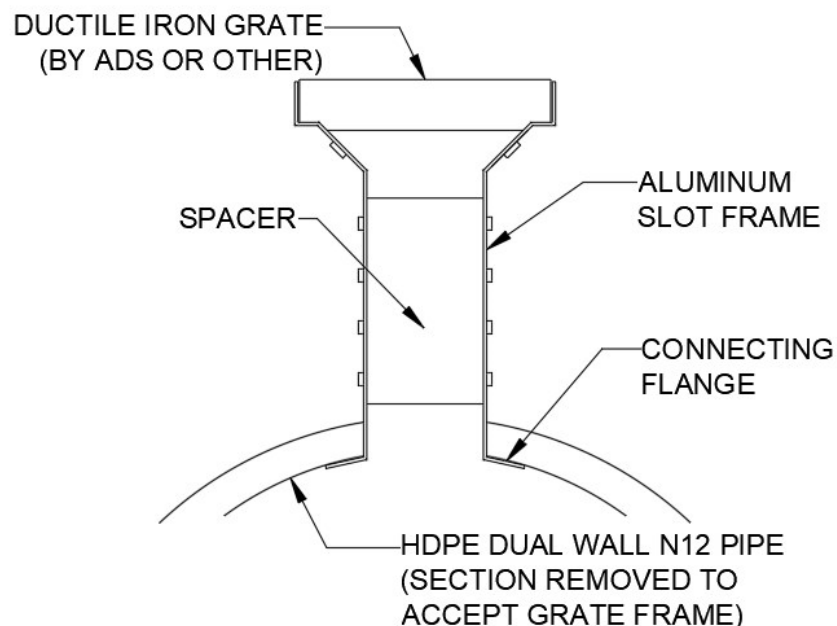

Duraslot XL Standard Dimensions

|                                 | Nominal Pipe Diameter in (mm) |           |           |           |           |           |            |            |            |
|---------------------------------|-------------------------------|-----------|-----------|-----------|-----------|-----------|------------|------------|------------|
|                                 | 6" (150)                      | 8" (200)  | 10" (250) | 12" (300) | 15" (375) | 18" (450) | 24" (600)  | 30" (750)  | 36" (900)  |
| L – Drain Grate Length          | 118.5 (3010)                  |           |           |           |           |           |            |            |            |
| H – 2.5" (62.5 mm) Slot         | 3.0 (76)                      | 3.0 (76)  | 3.0 (76)  | 3.5 (89)  | 3.75 (95) | 4.0 (102) | 4.75 (121) | 5.0 (127)  | 5.25 (133) |
| H – 6.0" (160 mm) Slot          | 6.5 (165)                     | 6.5 (165) | 6.5 (165) | 7.0 (178) | 7.0 (178) | 7.0 (178) | 7.25 (184) | 8.25 (210) | 8.25 (210) |
| O – Opening Width               | 5.0 (127)                     |           |           |           |           |           |            |            |            |
| R – Slot Width                  | 0.316 (8)                     |           |           |           |           |           |            |            |            |
| S – Slot Width                  | 2.25 (57)                     |           |           |           |           |           |            |            |            |
| W – Pipe Width with Corrugation | 0.46 (12)                     | 0.61 (15) | 0.73 (19) | 1.15 (29) | 1.30 (33) | 1.57 (40) | 1.86 (47)  | 2.55 (65)  | 2.85 (72)  |

Note:

1. Custom slot heights available upon request. Production of custom slots will require approval by the Duraslot Project Engineer. Signed shop drawings also required from interested party.
2. Other grate material options available upon request. Contact local ADS representative for availability of grate material option.

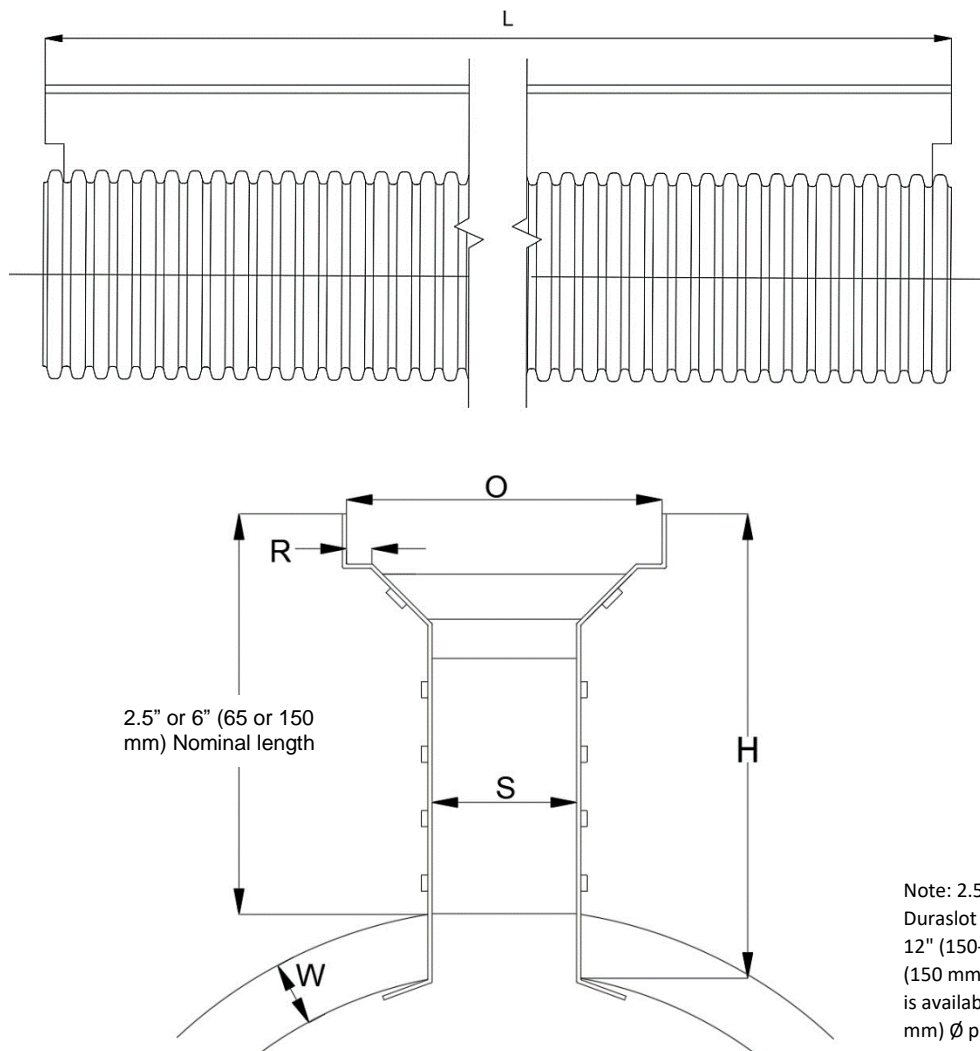

Note: 2.5" (65 mm) Standard Duraslot XL is available in 6" – 12" (150-300 mm) Ø pipe and 6" (150 mm) Standard Duraslot XL is available in 6" – 36" (150-900 mm) Ø pipe.