

1099CGC

APPROX. WEIGHT = 6.42 LBS

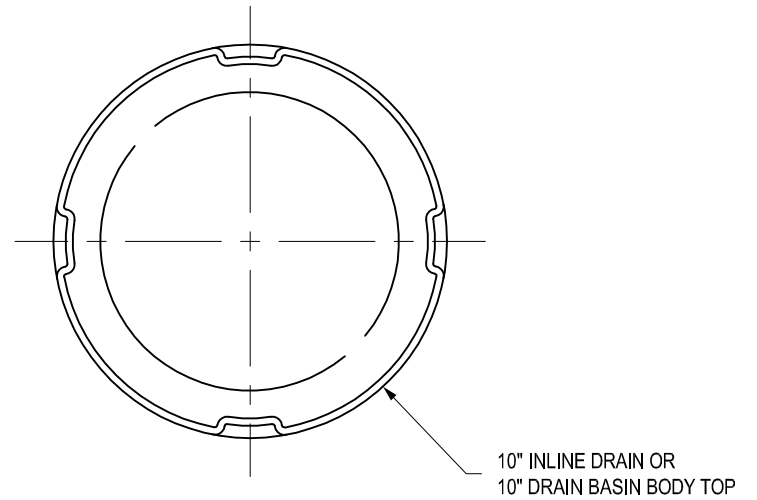
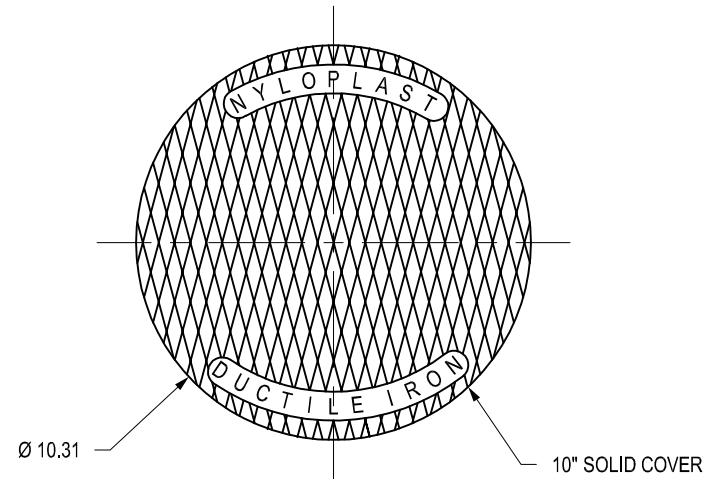
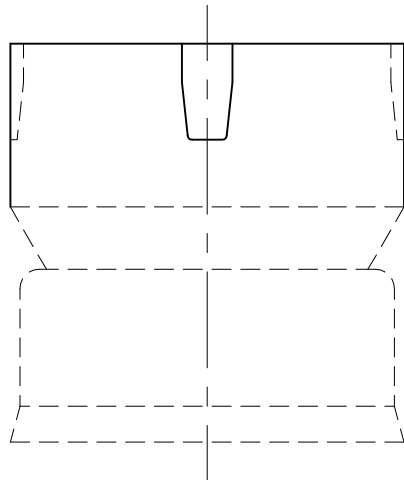
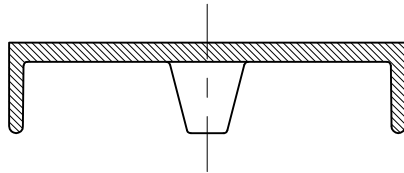

DIMENSIONS ARE FOR REFERENCE ONLY

ACTUAL DIMENSIONS MAY VARY

DIMENSIONS ARE IN INCHES

COVER HAS LIGHT DUTY RATING

QUALITY: MATERIALS SHALL CONFORM TO ASTM A536 GRADE 70-50-05

PAINT: CASTINGS ARE FURNISHED WITH A BLACK PAINT

LOCKING DEVICE AVAILABLE UPON REQUEST SEE DRAWING NO.

7001-110-039

THIS PRINT DISCLOSES SUBJECT MATTER IN WHICH NYLOPLAST HAS PROPRIETARY RIGHTS. THE RECEIPT OR POSSESSION OF THIS PRINT DOES NOT CONFER, TRANSFER, OR LICENSE THE USE OF THE DESIGN OR TECHNICAL INFORMATION SHOWN HEREIN REPRODUCTION OF THIS PRINT OR ANY INFORMATION CONTAINED HEREIN, OR MANUFACTURE OF ANY ARTICLE HEREFROM, FOR THE DISCLOSURE TO OTHERS IS FORBIDDEN, EXCEPT BY SPECIFIC WRITTEN PERMISSION FROM NYLOPLAST.

©2013 NYLOPLAST

DRAWN BY	EBC	MATERIAL
DATE	03-03-06	DUCTILE IRON
REVISED BY	CCA	PROJECT NO./NAME
DATE	08-27-13	
DWG SIZE	A	SCALE 1:5 SHEET 1 OF 1

	3130 VERONA AVE BUFORD, GA 30518 PHN (770) 932-2443 FAX (770) 932-2490 www.nyloplast-us.com
	TITLE
10 IN SOLID COVER ASSEMBLY	
DWG NO.	7001-110-199 REV C