

Technical Note

TN 5.09 Thermoplastic Pipe and Utility Crossings

Introduction

Underground utilities include storm sewer, electric, sanitary sewer, gas, water, telephone and cable. Utility conflicts are typically avoided during the design process. However, in some cases, existing utilities are not properly identified or located during the design process. In other instances, the location of the utility is known, but adequate construction controls are not in place. Both can result in a negative impact to an existing utility when installing a new utility. The purpose of this Technical Note is to provide additional information on the impact of utility crossings. While the discussion centers on the use of thermoplastic (high density polyethylene, HDPE and polypropylene, PP, specifically) pipe, there are documented cases of all types of pipes being affected, and in some cases damaged, by subsequent utility activity nearby.

Design Considerations

Many issues associated with utility disturbances can be avoided during the design process. The design will depend on the type of utility that is installed which may also dictate the depth. Typically, sanitary sewers are buried the deepest and located outside the roadway section. Water lines are generally the next deepest utility and usually are placed a minimum of 5 feet horizontally from sanitary sewers to prevent contamination. Some municipalities locate sanitary and water utilities on opposite sides of the roadway to minimize the potential for disturbance and contamination. Gas, electric and telephone utilities are generally located outside the pavement section on one side of the street in a utility corridor and are usually shallower than water and sanitary utilities. Storm sewer depth can be shallow depending on the terrain and outlet locations. Storm sewers can be located in the roadway or parallel to the roadway. The associated outfalls and area drains can be located outside the right of way in an easement. Since storm sewers are gravity flow drainage, their depth can vary more than other utilities. Most municipalities have ordinances or standards on utility locations and separate distances to minimize and prevent conflicts.

Excavation Considerations

For most municipalities, a statewide one-call utility location system is in place to locate the presence of existing utilities. It is extremely important in the case of electrical, gas and high-pressure water lines that contractors exercise care to avoid cutting these utilities, as the results can be catastrophic, even fatal. Although not catastrophic, the cutting of sanitary and storm sewers can cause maintenance and flooding concerns.

Construction organizations typically recommend that a utility survey be conducted prior to construction activities. The utility survey is conducted to accurately locate all existing (active and abandoned) utilities within the area of interest that could conflict with the planned construction. The Engineer, using records and drawings from various utility owners as a starting point, may conduct the survey. It is advisable to use specialty underground survey firms to confirm the locations and characteristics of the utilities shown on the drawings. It is especially important to search for abandoned utilities and note their locations and characteristics.⁽¹⁾

Once construction begins, the type of equipment that is utilized can have an impact on the potential for utility damage. The use of traditional excavation equipment, such as backhoes or excavators, is very common for the installation of utilities. The use of traditional equipment can provide the best opportunity to locate an existing utility that has not been previously identified. This type of equipment can damage all pipe types if contacted. However, it also offers the operator the opportunity to periodically inspect the excavation for signs of existing utilities. The location of an existing utility location can often be identified before it is impacted by excavation equipment.

Trenching equipment is common for a small diameter pipe or cable installation and can be designed specifically for rock installations. This equipment is operated continuously with little opportunity for inspection of the excavation for other utilities. Lastly, the equipment operates at a very high decibel level further impeding the operator's ability to determine if an existing utility has been encountered. As a result, the use of trenching equipment can impact all pipe types with little to no awareness by the operator.

Directional boring or drilling is being used more frequently for the installation of utilities. It is a steerable trenchless method of installing utilities along a prescribed subsurface bore path by using a surface launched drilling rig, with minimal impact on the surrounding area. Directional boring is used when excavating or trenching is not practical. The technique has been used extensively in urban areas as it eliminates the need for open cut trenches. To be successful, the operator must have thorough knowledge of existing utilities so that he can plan the alignment and avoid damaging those utilities. In the case of small diameter utility installation, it is difficult to identify the nature and type of underground obstructions. Furthermore, certain directional equipment is designed to bore through rock and can operate at pressures of up to 30,000 psi. In this instance, an underground utility, regardless of material of construction, would be negatively impacted. Since uncontrolled drillings can lead to such damages, various agencies/government authorities owning the urban 'right-of-way' or the utilities that have authority over underground installations have formed their own rules for safe work execution when using this technology.

The other installation procedure that can have an impact to an existing utility are those that entail "driving" an object from the surface. This typically applies to fencepost or guard rail. In this application, the operator needs to be fully aware of subsurface utilities. The equipment involved with this installation can operate with enough force to damage an underground utility regardless of pipe type. As a result, equipment manufacturers of this type recommend that all underground utilities be properly located so as to avoid potential damage to those utilities.

Installation Considerations

The preferable method of thermoplastic pipe storm sewer installation is to prepare a suitable trench or embankment installation in accordance with recommended depths, widths, soil types and compaction levels. When working adjacent to existing utilities, appropriate pipe spacing needs to be maintained to ensure the stability of the trench and the overall long term performance of the thermoplastic pipe storm sewer. The required pipe spacing will depend on pipe diameter, pipe depth and backfill type.

In some cases, the proximity of an existing utility prevents the use of traditional backfill materials due to lack of adequate clearance for compaction to occur. In this case, controlled low strength material (CLSM) or flowable fill is an appropriate alternative. This is a low strength (120 psi) material that when installed, does not require any compactive effort. Due to its consistency, the material is self forming and self compacting. However, when it dries, it forms an encasement type backfill material that can be excavated if necessary. The use of flowable fill still requires a certain minimum distance between utilities to provide the necessary structural support. As with traditional backfill, this will depend on pipe diameter and pipe depth.

In situations in which a utility crosses too closely or comes in contact with a HDPE or PP storm sewer, CLSM may not be sufficient to provide the necessary structural support. For this condition, concrete encasement is recommended.

Slope/Soil Considerations

Effects of adjacent excavation and response of pipe materials are issues of soil stability until the excavation encroaches on the pipe embedment zone. The long term performance characteristics of any pipe material can be compromised in cases where slope failure occurs. If the pipe is within the failure plane, it will most likely be impacted as a result of the slope failure. The potential for this situation increases as the depth of the installation increases. If an installation was deep enough to cause concerns regarding slope stability and possible failure, it is likely that OSHA regulations would require shoring, trench box or another protective system. For trench installation, Federal regulations mandate an adequate protective system be required at depths greater than five feet ⁽²⁾ and some state safety codes reduce this limit to four feet. The use of a protective system would limit the impact of an adjacent installation on an existing utility regardless of pipe material.

For installations that occur beneath existing HDPE or PP pipe, exposure of pipe or loss of material must be avoided. Typically, if a minimum of 12 inches of stable, compacted material is maintained between the existing thermoplastic pipe and the proposed utility, the thermoplastic pipe will have adequate structural support. There are several options available for installations of this type. In order to address the specific site conditions, please contact and ADS representative for additional information on this type of installation.

When dealing with slope/soil stability while excavating next to an existing utility, the most extreme circumstance that can occur is slope failure resulting in exposure of the existing pipe. The complete exposure of the sidewall of a buried HDPE or PP pipe should and can be avoided with proper installation procedures, utility corridors, shoring etc. Long term exposure of this type should be avoided for any material and is not specific to thermoplastics. The exposed condition should be corrected and the pipe returned to a backfilled condition as soon as possible. To avoid long term performance issues, the exposed pipe should be backfilled to conditions equal to or better than the original installation. To avoid uncertainty, an agency may prescribe CLSM material be used when existing pipe is exposed.

Methods of Identifying Utilities

Certain construction practices can be helpful in preventing damage by subsequent utility installation. These include but are not limited to:

Backfill Materials

Using a select backfill can alert the operator of the possibility of a utility before it is impacted. A stone or sand backfill in areas where native soils are clayey or silty could be used in this case. It should be noted that the use of such material is strictly for utility location and not for structural purposes and can apply to all pipe material types.

Locator Tape

Locator tape is an inexpensive way to notify an operator of a utility. Placing locator tape above the pipe trench would notify the operator of a utility conflict prior to damaging the pipe. Figure 1 provides two examples of the application of locator tape for a utility installation.

Figure 1: Use of Locator Tape with Underground Utilities

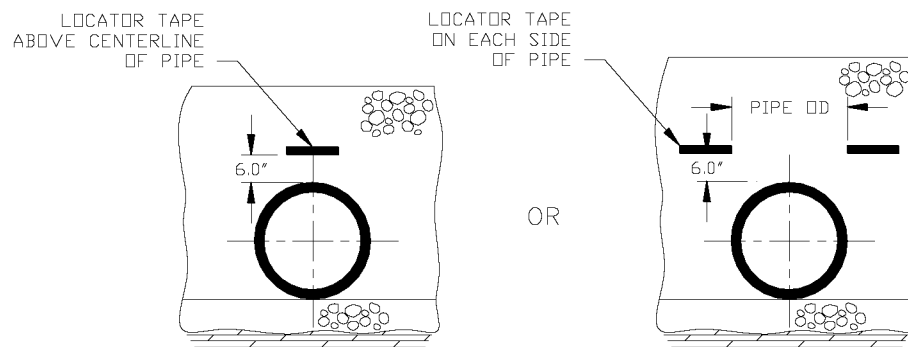

Ordinances

The most effective way of preventing utility cuts is to enforce ordinances for the phasing and spacing of utility locations as discussed previously. Furthermore, the ordinances need to be worded such that individual utility contractors are responsible for damages they create. Some agencies have enforced their ordinances by requiring utility contractors to repair utility cuts within a specified time frame after the damage is identified or the agency will do the repair and charge the utility contractor. It may also be necessary to prescribe standards for re-establishing backfill conditions if the pipe envelope of an existing utility is compromised.

Repair of Utility Cuts for HDPE & PP Pipe

One of the many benefits of HDPE and PP pipe is the ability to easily repair damage. The type of repair will depend on the nature and extent of the damage. Repair will typically fall into one of three categories which are discussed further below. More specific information on repair methods can be found in Technical Note 5.03 *HDPE Pipe Repair Options*, Technical Note 5.12 *HP STORM Drainage Pipe Repair Options*, Technical Note 5.13 *SaniTite HP Repair Options*.

Split Couplers

For relatively small utility cuts (3" - 4" [75 mm - 100 mm] long cuts perpendicular to the centerline of the pipe), repairs can be made by uncovering the damaged section and placing a split coupler over it. The split coupler can then be backfilled in place covering the damaged portion of pipe. This can be enhanced by wrapping the repair with fabric. Another option in lieu of a split coupler is a Mar-Mac® Polyseal coupler. A Mar-Mac coupler should be used when repairing triple wall pipe and a soil-tight joint is allowed by project specifications.

Pipe Sections

For larger utility cuts (greater than 4" [100 mm] along the pipe axis) the damaged section can be uncovered and removed to a point where there is no longer any damage. The cuts should be made in the valleys of the corrugations (Figure 2) and a new section of pipe cut to length and joined to the existing pipe with split couplers (Figure 3). The split coupler can be enhanced by wrapping the repair with fabric. Another option in lieu of a split coupler with fabric is the use of a Mar-Mac Polyseal coupler. A Mar-Mac coupler should be used when repairing triple wall pipe and a soil-tight joint is allowed by project specifications.

Figure 2: Pipe Cut Location



Figure 3: Split Band Installation



Internal Seals

For small utility cuts (3-4" [75-100 mm] long holes), it is often economical to seal the pipe internally. Several commercially available internal seals are available. Internal seals use polyisoprene rubber membranes that are secured to the inside of the pipe with expanding stainless steel bands. Generally, internal seals are only appropriate for larger diameter (24" [600 mm] or greater) pipes since internal access is necessary. Additional information can be found in the repair method technical notes for the respective ADS pipe product.

Conclusions

All pipe types are susceptible to damage from the installation of adjacent utilities. Damage can be prevented during the design phase with proper utility location and phasing or during the construction phase with proper utility location. If utility location is not exact, further damage can be minimized through the selection of installation equipment and the use of trench boxes or shoring. Furthermore, in the event that HDPE or PP pipe is physically damaged during the construction process, repair is relatively simple and inexpensive.

Footnotes

¹ Chapter 4 – Planning, Horizontal Directional Drilling, Good Practices and Guidelines, Horizontal Directional Drilling Consortium, 2004

² 29 CFR 1926.652(a).

