

DUAL WALL FABRICATED REDUCING WYES 42"×4" - 42"×10" DIAMETER

PART #	PIPE SIZE	A	B	C	JOINT
4280AN	42 x 4 in (1050 x 100 mm)	51.4 in (1306 mm)	41.9 in (1064 mm)	49.8 in (1265 mm)	*
4280AN65B	42 x 4 in (1050 x 100 mm)	41.1 in (1044 mm)	41.9 in (1064 mm)	44.6 in (1133 mm)	WT
4281AN	42 x 6 in (1050 x 150 mm)	51.4 in (1306 mm)	44.0 in (1118 mm)	49.8 in (1265 mm)	*
4281AN65B	42 x 6 in (1050 x 150 mm)	41.1 in (1044 mm)	44.0 in (1118 mm)	44.6 in (1133 mm)	WT
4282AN	42 x 8 in (1050 x 200 mm)	56.5 in (1435 mm)	45.7 in (1161 mm)	52.4 in (1331 mm)	*
4282AN65B	42 x 8 in (1050 x 200 mm)	46.3 in (1176 mm)	45.7 in (1161 mm)	47.2 in (1199 mm)	WT
4283AN	42 x 10 in (1050 x 250 mm)	61.7 in (1567 mm)	47.6 in (1209 mm)	55.0 in (1397 mm)	*
4283AN65B	42 x 10 in (1050 x 250 mm)	51.4 in (1306 mm)	47.6 in (1209 mm)	49.8 in (1265 mm)	WT

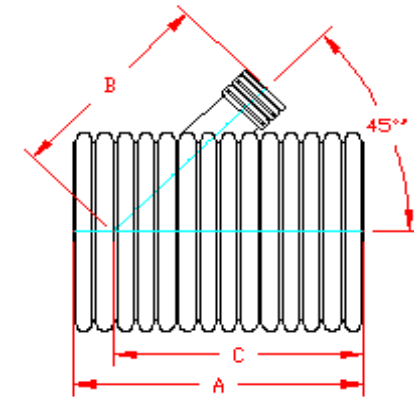

PLAIN END

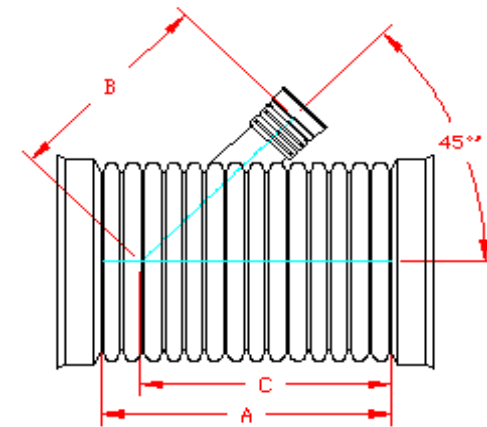

WT (INCLUDES 3 GASKETS)

* = PLAIN END
ST = SOIL TIGHT
WT = WATER TIGHT

NOTE: ALL FITTINGS DIMENSIONS ARE FOR REFERENCE ONLY

© 2023 Advanced Drainage Systems, Inc.



DRAWING #:	2340	
DRAWN BY:	JCB	06.14.06
APPROVED BY:	JCB	06.26.07
REVISIONS:	TJR	05.30.08