

TOP VIEW

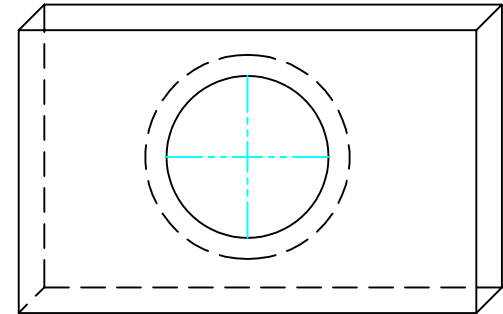

FRONT VIEW

PIPE SIZE	HP STORM PIPE OD	N-12 STORM PIPE OD	"A" MIN. HOLE Ø
12" (300mm)	14.5" (368mm)	14.5" (368mm)	19.50" (495mm)
15" (375mm)	17.6" (447mm)	18" (457mm)	23.00" (584mm)
18" (450mm)	21.2" (538mm)	22" (559mm)	26.50" (673mm)
24" (600mm)	27.8" (706mm)	28" (711mm)	33.25" (845mm)
30" (750mm)	35.1" (892mm)	36" (914mm)	40.50" (1029mm)
36" (900mm)	41.1" (1044mm)	42" (1067mm)	47.00" (1194mm)
42" (1050mm)	47.7" (1212mm)	48" (1219mm)	53.00" (1346mm)
48" (1200mm)	53.6" (1361mm)	54" (1372mm)	59.00" (1499mm)
60" (1500mm)	66.3" (1684mm)	67" (1702mm)	72.00" (1829mm)

NOTES:

1. INSERT PIPE INTO HEADWALL, WITH PIPE RESTING ON BEDDING. THE PIPE SHOULD BE IN THE APPROXIMATE CENTER OF THE OPENING.
2. GROUT PIPE INTO CONCRETE STRUCTURE WITH NON-SHRINK GROUT. SOLID MASONRY UNITS, FULLY GROUTED IN PLACE, MAY BE USED TO HELP FILL LARGE VOIDS.
3. PIPE AT AND AROUND STRUCTURE CONNECTION TO BE INSTALLED PER ASTM D2321, LATEST EDITION. SEE STANDARD DETAIL 100 SERIES FOR PIPE INSTALLATION DETAILS AND TECHNICAL NOTE: 5.04 CONNECTIONS TO MANHOLES AND STRUCTURES FOR ADDITIONAL INFORMATION.
4. PIPE BELLS TO BE COMPLETELY REMOVED BEFORE MAKING A CONNECTION.
5. MINIMUM COVER: MINIMUM COVER, H, IN NON-TRAFFIC APPLICATIONS (GRASS OR LANDSCAPE AREAS) IS 12" (300mm) FROM THE TOP OF PIPE TO GROUND SURFACE. ADDITIONAL COVER MAY BE REQUIRED TO PREVENT FLOTATION. SEE TECHNICAL NOTE: 5.05 PIPE FLOTATION FOR ADDITIONAL INFORMATION. FOR TRAFFIC APPLICATIONS, MINIMUM COVER, H, IS 12" (300mm) UP TO 48" (1200mm) DIAMETER PIPE AND 24" (600mm) OF COVER FOR 60" (1500mm) DIAMETER PIPE, MEASURED FROM TOP OF PIPE TO BOTTOM OF FLEXIBLE PAVEMENT OR TO TOP OF RIGID PAVEMENT.

© 2026 ADS, INC.

REV 3	CONNECTIONS, OD'S, NOTES	RKC	3/5/26	CJD
REV.	DESCRIPTION	BY	MM/DD/YY	CHK'D

ADVANCED DRAINAGE SYSTEMS, INC. ("ADS") HAS PREPARED THIS DETAIL BASED ON INFORMATION PROVIDED TO ADS. THIS DRAWING IS INTENDED TO DEPICT THE COMPONENTS AS REQUESTED. ADS HAS NOT PERFORMED ANY ENGINEERING OR DESIGN SERVICES FOR THIS PROJECT, NOR HAS ADS INDEPENDENTLY VERIFIED THE INFORMATION SUPPLIED. THE INSTALLATION DETAILS PROVIDED HEREIN ARE GENERAL RECOMMENDATIONS AND ARE NOT SPECIFIC FOR THIS PROJECT. THE DESIGN ENGINEER SHALL REVIEW THESE DETAILS PRIOR TO CONSTRUCTION. IT IS THE DESIGN ENGINEERS RESPONSIBILITY TO ENSURE THE DETAILS PROVIDED HEREIN MEETS OR EXCEEDS THE APPLICABLE NATIONAL, STATE, OR LOCAL REQUIREMENTS AND TO ENSURE THAT THE DETAILS PROVIDED HEREIN ARE ACCEPTABLE FOR THIS PROJECT.

N-12/HP STORM GROUTED STANDARD END SECTION CONNECTION DETAILS

DRAWING NUMBER: STD-113F



4640 TRUEMAN BLVD
HILLIARD, OHIO 43026

DRAWN BY:	NAB
DATE:	12/17/2020
CHK'D BY:	CKM
SCALE:	NTS
SHEET:	1 OF 1