

**BELL-BELL ADAPTER FOR 6 - 10 IN
(150 - 250 mm) PIPE DIAMETER**

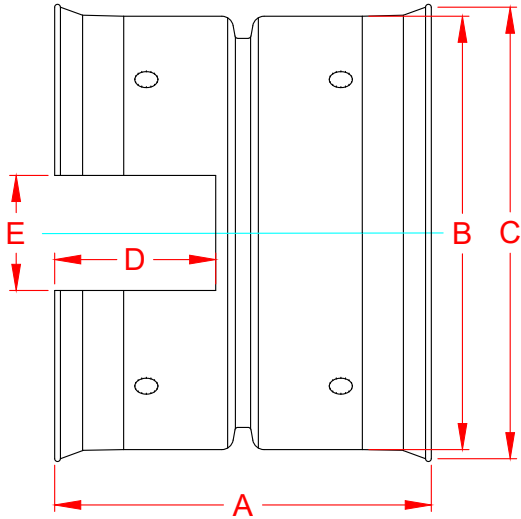

**ST CLEATED EXTERNAL ADAPTER FOR 12 - 24 IN
(300 - 600 mm) PIPE DIAMETER**

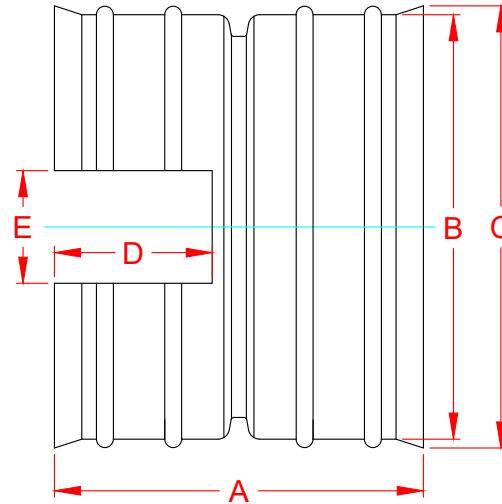

**SPLIT COUPLER ADAPTER FOR 30 - 36 IN
(750 - 900 mm) PIPE DIAMETER**

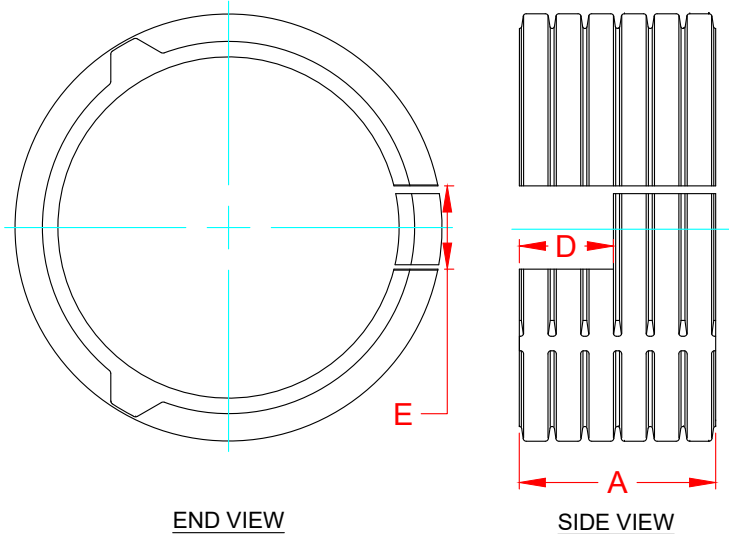

END VIEW

SIDE VIEW

ADAPTERS FOR DURASLOT DIMENSIONS

PIPE Ø, in (mm)	A, in (mm)	B, in (mm)	C, in (mm)	D, in (mm)	E, in (mm)	PRODUCT # (Std./Cust. Slot)
6 (150)	7.25 (184)	6.95 (177)	7.63 (194)	3.00 (76)	2.50 (64)	0662DS/ 0696DS
8 (200)	8.25 (210)	9.17 (233)	10.13 (257)	3.50 (89)	2.50 (64)	0862DS/ 0896DS
10 (250)	9.25 (235)	11.56 (294)	12.13 (308)	4.00 (100)	2.50 (64)	1062DS/ 1096DS
12 (300)	14.00 (356)	14.60 (371)	15.40 (391)	5.50 (140)	2.50 (64)	1262DS/ 1296DS
15 (375)	16.00 (406)	17.75 (449)	18.60 (472)	6.50 (165)	2.50 (64)	1562DS/ 1596DS
18 (450)	18.00 (457)	21.40 (544)	22.40 (569)	7.50 (191)	2.50 (64)	1862DS/ 1896DS
24 (600)	14.80 (374)	28.20 (716)	29.25 (743)	6.00 (152)	2.50 (64)	2462DS/ 2496DS
30 (750)	16.50 (419)	N/A	NA	8.00 (203)	2.50 (64)	3062DS/ 3096DS
36 (900)	20.80 (528)	N/A	NA	10.00 (254)	2.50 (64)	3662DS/ 3696DS

ADAPTERS FOR DURASLOT XL DIMENSIONS

PIPE Ø, in (mm)	A, in (mm)	B, in (mm)	C, in (mm)	D, in (mm)	E, in (mm)	PRODUCT # (Std./Cust. Slot)
6 (150)	7.25 (184)	6.95 (177)	7.63 (194)	3.00 (76)	2.50 (64)	0662DSXL/ 0696DSXL
8 (200)	8.25 (210)	9.17 (233)	10.13 (257)	3.50 (89)	2.50 (64)	0862DSXL/ 0896DSXL
10 (250)	9.25 (235)	11.56 (294)	12.13 (308)	4.00 (100)	2.50 (64)	1062DSXL/ 1096DSXL
12 (300)	14.00 (356)	14.60 (371)	15.40 (391)	5.50 (140)	2.50 (64)	1262DSXL/ 1296DSXL
15 (375)	16.00 (406)	17.75 (449)	18.60 (472)	6.50 (165)	2.50 (64)	1562DSXL/ 1596DSXL
18 (450)	18.00 (457)	21.40 (544)	22.40 (569)	7.50 (191)	2.50 (64)	1862DSXL/ 1896DSXL
24 (600)	14.80 (374)	28.20 (716)	29.25 (743)	6.00 (152)	2.50 (64)	2462DSXL/ 2496DSXL
30 (750)	16.50 (419)	N/A	NA	8.00 (203)	2.50 (64)	3062DSXL/ 3096DSXL
36 (900)	20.80 (528)	N/A	NA	10.00 (254)	2.50 (64)	3662DSXL/ 3696DSXL

NOTES:

1. ALL FITTING DIMENSIONS ARE FOR REFERENCE ONLY.
2. ALL HARDWARE REQUIRED FOR ASSEMBLY IS INCLUDED WITH THE PURCHASE OF A COUPLER BAND, INCLUDING A SLOT END CAP.

2	Updated Layers & Logo	KJS	01/13/25	-
REV.	DESCRIPTION	BY	MM/DD/YY	CHK'D

© 2025 ADS, INC.

ADVANCED DRAINAGE SYSTEMS, INC. ("ADS") HAS PREPARED THIS DETAIL BASED ON INFORMATION PROVIDED TO ADS. THIS DRAWING IS INTENDED TO DEPICT THE COMPONENTS AS REQUESTED. ADS HAS NOT PERFORMED ANY ENGINEERING OR DESIGN SERVICES FOR THIS PROJECT, NOR HAS ADS INDEPENDENTLY VERIFIED THE INFORMATION SUPPLIED. THE INSTALLATION DETAILS PROVIDED HEREIN ARE GENERAL RECOMMENDATIONS AND ARE NOT SPECIFIC FOR THIS PROJECT. THE DESIGN ENGINEER SHALL REVIEW THESE DETAILS PRIOR TO CONSTRUCTION. IT IS THE DESIGN ENGINEERS RESPONSIBILITY TO ENSURE THE DETAILS PROVIDED HEREIN MEETS OR EXCEEDS THE APPLICABLE NATIONAL, STATE, OR LOCAL REQUIREMENTS AND TO ENSURE THAT THE DETAILS PROVIDED HEREIN ARE ACCEPTABLE FOR THIS PROJECT.

Duraslot & Duraslot XL Adapter	
DRAWING NUMBER: STD-1412	

 Advanced Drainage Systems, Inc.	4640 TRUEMAN BLVD HILLIARD, OHIO 43026
	DRAWN BY: KJS
	DATE: 04-18-2023
	SCALE: NTS
SHEET: 1 OF 1	