

SC-310 TECHNICAL SPECIFICATION

NTS

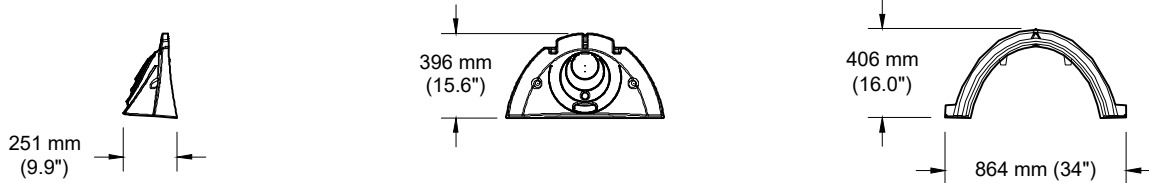
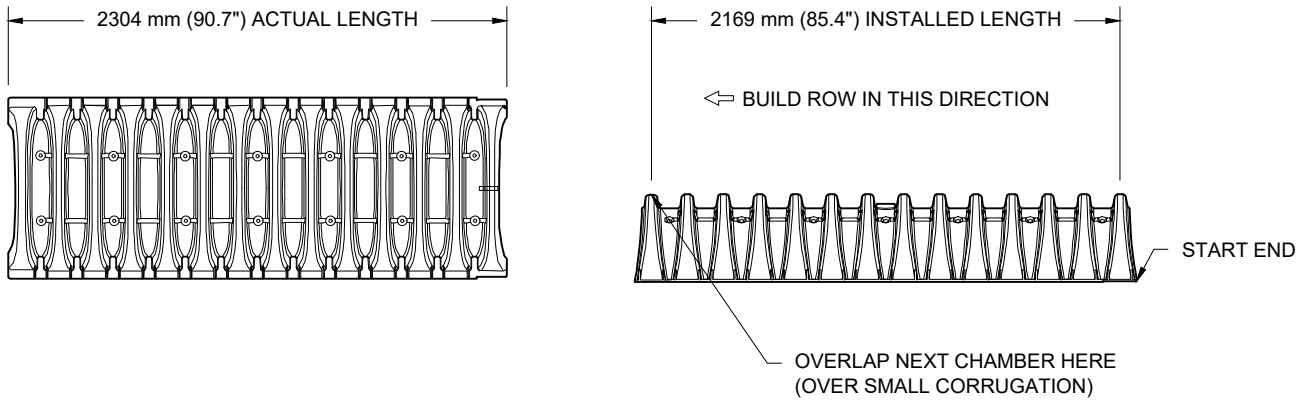

NOMINAL CHAMBER SPECIFICATIONS

SIZE (W X H X INSTALLED LENGTH)	864 mm X 406 mm X 2169 mm	(34.0" X 16.0" X 85.4")
CHAMBER STORAGE	0.42 m ³	(14.7 CUBIC FEET)
MINIMUM INSTALLED STORAGE*	0.83 m ³	(29.34 CUBIC FEET)
WEIGHT	16.8 kg	(35.0 lbs.)

*ASSUMES 150 mm (6") ABOVE AND BELOW CHAMBER; 75 mm (3") BETWEEN CHAMBERS

PART #	STUB	B	C
SC310EPE06TPC	150 mm (6")	147 mm (5.8")	---
SC310EPE06BPC		---	13 mm (0.5")
SC310EPE08TPC	200 mm (8")	89 mm (3.5")	---
SC310EPE08BPC		---	15 mm (0.6")
SC310EPE10TPC	250 mm (10")	36 mm (1.4")	---
SC310EPE10BPC		---	18 mm (0.7")
SC310ECEZ*	300 mm (12")	---	23 mm (0.9")

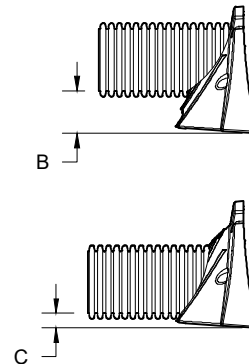

ALL STUBS, EXCEPT FOR THE SC310ECEZ ARE PLACED AT BOTTOM OF END CAP SUCH THAT THE OUTSIDE DIAMETER OF THE STUB IS FLUSH WITH THE BOTTOM OF THE END CAP. FOR ADDITIONAL INFORMATION CONTACT STORMTECH AT 1-888-892-2694.

* FOR THE SC310ECEZ THE 300 mm (12") STUB LIES BELOW THE BOTTOM OF THE END CAP APPROXIMATELY 6 mm (0.25"). BACKFILL MATERIAL SHOULD BE REMOVED FROM BELOW THE N-12 STUB SO THAT THE FITTING SITS LEVEL.

NOTE: ALL DIMENSIONS ARE NOMINAL; PRE-CORED END CAPS END WITH "PC"

TECHNICAL SPECIFICATIONS
SC-310 CHAMBER

DATE: 01/15/25
DRAWING #: 721-310_C
DRAWN: SMW
CHECKED: JLM

1-800-821-6710
WWW.STORMTECH.COM

StormTech[®]
Chamber System

4640 TRUEMAN BLVD
HILLIARD, OH 43026

ADS

THIS DRAWING HAS BEEN PREPARED BASED ON INFORMATION PROVIDED TO ADS/STORMTECH UNDER THE DIRECTION OF THE PROJECT'S ENGINEER OF RECORD (EOR) OR OTHER PROJECT REPRESENTATIVE. THIS DRAWING IS NOT INTENDED FOR USE IN BIDDING OR CONSTRUCTION WITHOUT THE EOR'S PRIOR APPROVAL. EOR SHALL REVIEW THIS DRAWING PRIOR TO BIDDING AND/OR CONSTRUCTION. IT IS THE ULTIMATE RESPONSIBILITY OF THE EOR TO ENSURE THAT THE PRODUCT(S) DEPICTED AND ALL ASSOCIATED DETAILS MEET ALL APPLICABLE LAWS, REGULATIONS, AND PROJECT REQUIREMENTS.