

Technical Note

TN 1.10 EcoPure BioFilter® Considerations

Overview

The ADS EcoPure BioFilter is a manufactured water quality treatment device intended for removal of Total Suspended Solids (TSS), Oil & Grease, Trash, Bacteria, and Nutrients such as Nitrogen & Phosphorus. The versatile unit introduces the ability to receive both surface and subsurface runoff, allowing it to be installed in nearly any location. These two inlet modalities combine with the option for placement of plant life above the unit, which introduces a third inlet option – infiltration. Once installed, the unit's ability to treat through settling, filtration, and sorption ensure sufficient water quality treatment of the influent runoff.

System Components

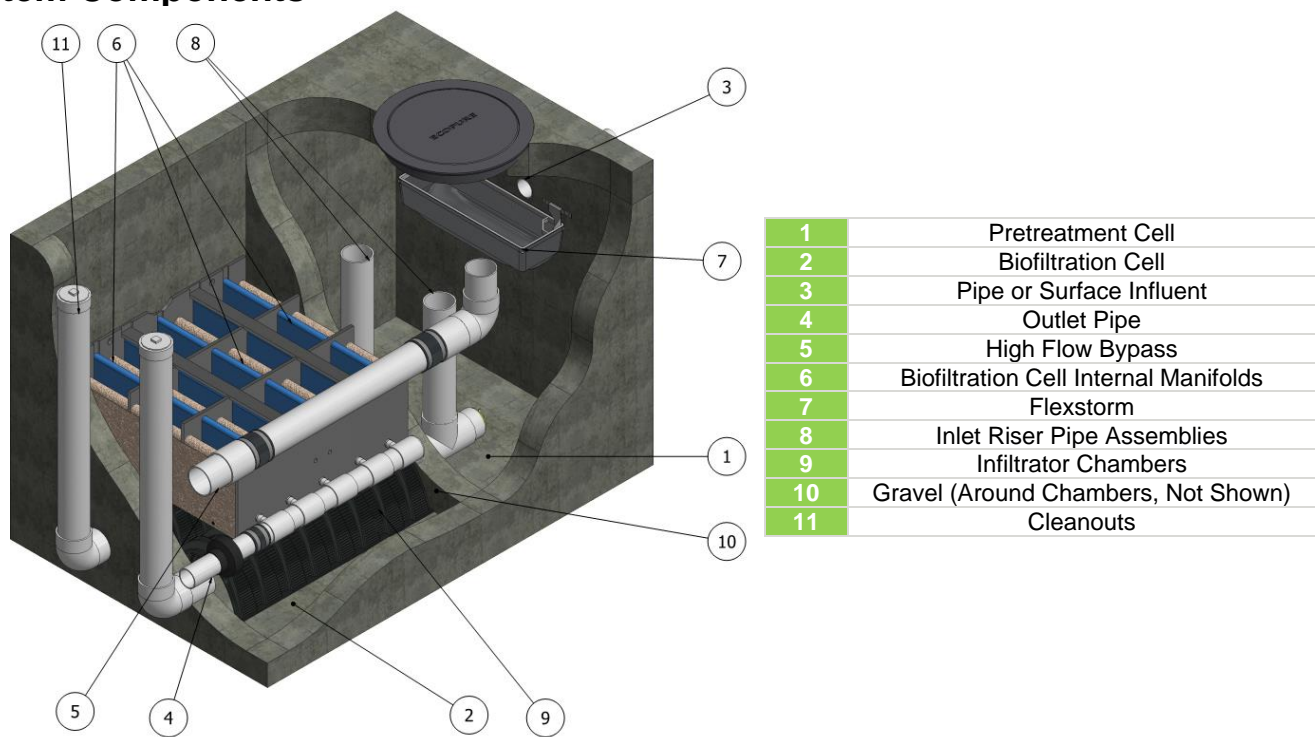

Figure 1: EcoPure Components

Concrete Vault designed for H-20 loading, meeting the specifications outlined in ASTM C857 and ASTM C858. The concrete shall have a minimum unconfined compressive strength of 4000psi. The rim or grate shall have a minimum 24" opening. The standard vault will have two chambers.

FlexStorm Pure™ Wall-Mounted Filter will provide initial filtration of larger trash and debris upon the runoff's entering into the unit. The proprietary geotextile design contained within the filter is the unit's first line of defense against pollutants.

PVC Manifold Piping shall be used to comprise many of the internal components, such as the outlet manifold, internal bypass, inlet riser assemblies, and cleanout risers. These components shall meet ASTM D1785 and will be provided to the contractor partially pre-cut and/or pre-assembled.

Biofiltration Internal HDPE Manifold comprised of perforated drain tile and PVC pipe fittings that shall meet ASTM D1785. This portion of the unit, shown by both items 6 and 4 in *Figure 1*, promotes the water's exiting of the unit following filtration by the proprietary granular media.

Precut Infiltrator Chambers, represented by item 9, will connect the inlet standpipe to the cleanout risers and facilitate the influent's entrance into the second chamber, following its bypass through the inlet riser.

Select Plant Media can be placed above the biofiltration cell internal manifolds and adjacent to the surface inlet, which will promote filtration practices by method of surface infiltration. Please reference the *Region Specific EcoPure BioFilter Plant List* to determine what vegetation can be utilized in your area.

Functionality

- 1) Water enters the unit through a throat inlet or subsurface influent pipe. The water passes through the FlexStorm Inlet Filter immediately upon entering the unit.

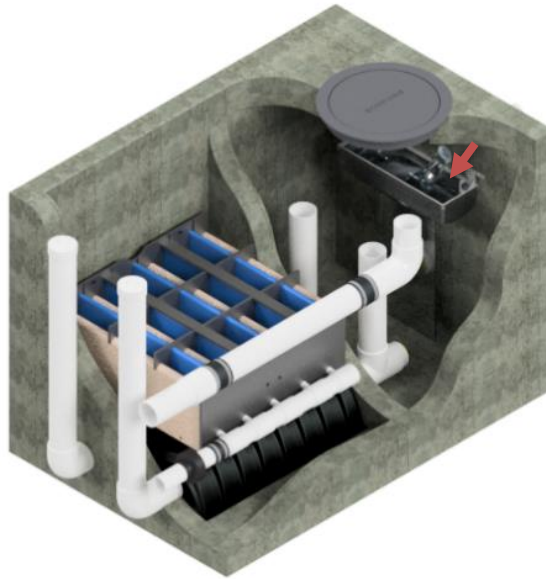

Figure 2: Water begins to inlet into unit and is filtered through the FlexStorm.

- 2) Water begins to collect in the pretreatment cell, the upstream of the two chambers in the vault. The collection of water in this cell allows for settlement of TSS before further conveyance.

- 3) After water has ponded high enough in the pretreatment cell, it will convey through the inlet risers to the Infiltrator Chambers. The height of the inlet risers is set so that this entrance point will create enough driving head for the water to filter through the proprietary granular media shortly after achieving flow through the risers.

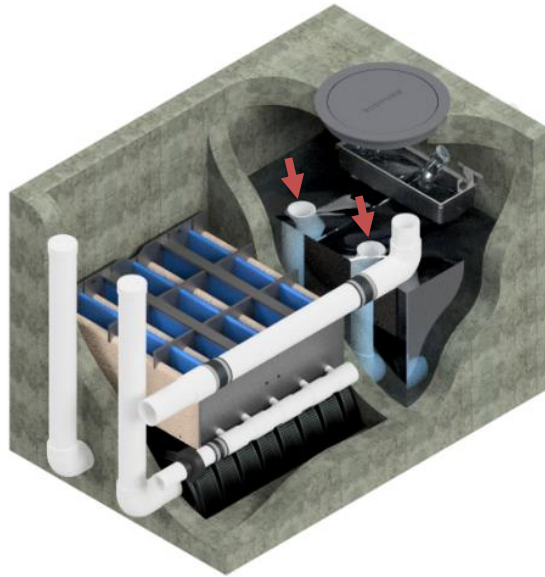

Figure 3: Influent backs up in the unit until it crests the inlet risers.

- 4) Following filtration by this engineered media, the water will eventually collect in the HDPE internal manifold where it will be conveyed to the PVC outlet manifold and then downstream.

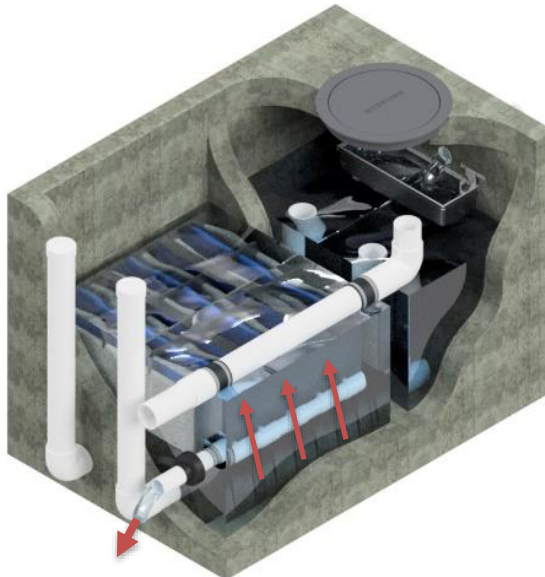

Figure 4: Treated influent ponds in the treatment bay following filtration as it waits to exit through the PVC manifold.

- 5) During peak storm events where the treatment capacity of the system is exceeded, water will pond up higher in the pretreatments cell and begin to flow through the internal bypass pipe to be conveyed directly downstream.

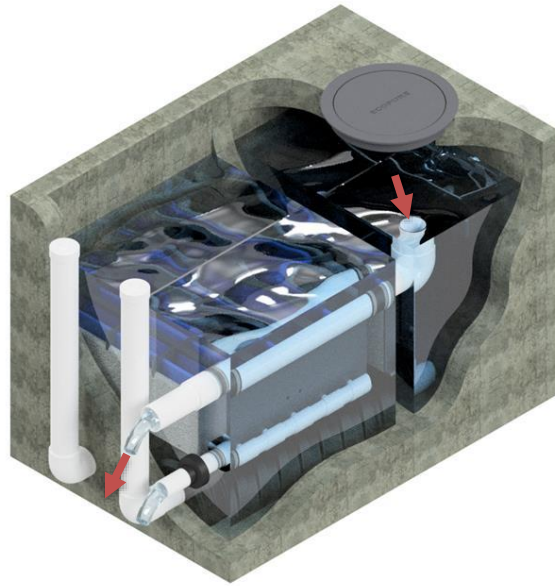

Figure 5: Influent exceeds inlet capacity and exits the system via bypass pipe.

Configuration Options

In addition to providing water quality treatment to runoff influent, the EcoPure Biofilter was also designed with green infrastructure in mind. If site conditions allow, the unit can be fitted with soil and accompanying plant media above the treatment bay. This introduces a third inlet method, being infiltration through the soil layer.

An important consideration when utilizing plants is the depth of the unit. Depth is crucial to consider to ensure that the soil layer is an appropriate height for the selected plant media. During design, depth of the vault should be considered by the landscape architect while selecting plant media to ensure the vault dimensions do not detriment the vegetation. The minimum depth between the plant bed surface and filter media shall be 24in, as a function of the minimum vault height and depth of media provided.

Treatment Parameters

The stormwater filtration system should be sized to be capable of treating 100% of the required treatment flow rate at full sediment loading conditions. Proper sizing of the unit results in removal of 85% of the TSS, 70% Total Phosphorous, and 35% Total Nitrogen.

EcoPure Unit	Unit Dimensions - ft (m)	Treatment Rate - cfs (L/s)	Mass capture Capacity - lb (kg)
EcoPure 60	5x8 (1.5x2.4)	0.134 (3.8)	194 (88)
EcoPure 120	5x13 (1.5x4.0)	0.270 (7.6)	389 (176)
EcoPure 180	5x20 (1.5x6.1)	0.400 (11.3)	583 (264)
EcoPure 240	10x13 (3.0x4.0)	0.530 (15.0)	778 (353)
EcoPure 360	10x20 (3.0x6.1)	0.800 (22.7)	1166 (529)

The treatment rates stated above require a minimum vault depth of 60" from base of sump to base of the top slab. This depth ensures that treatment rates will be met prior to surcharging of the unit. This minimum vault height aligns with the minimum inlet riser height of 40" (1000 mm), and the minimum bypass pipe height of 55" (1375 mm) above the vault floor.

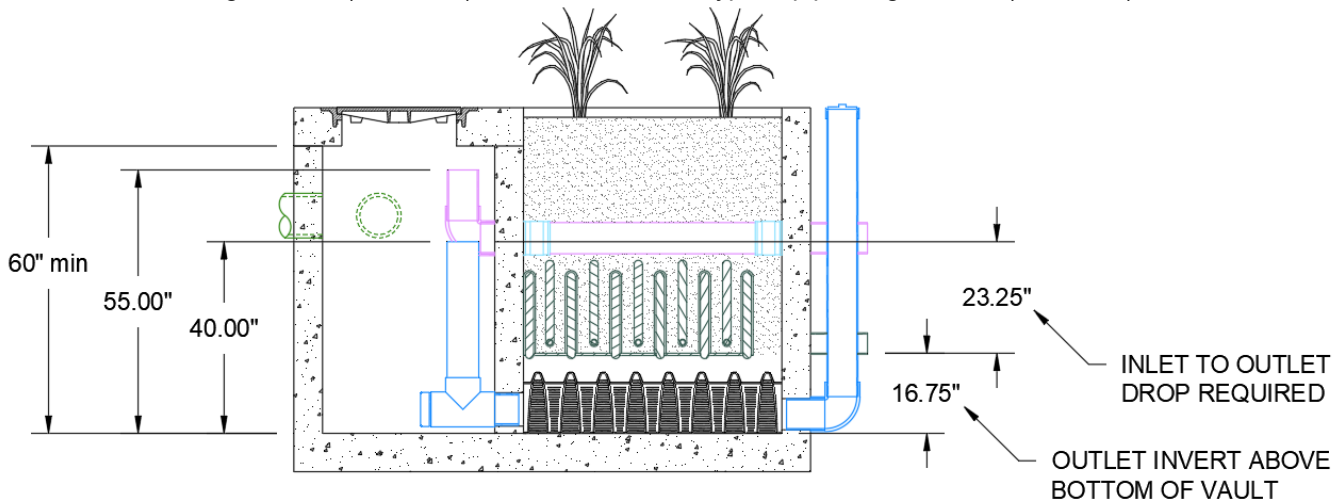

Figure 6: Cross-section of EcoPure displaying heights of inlet risers, bypass pipe, and base of casting.

Design Considerations – Inverts/Elevations

In addition to ensuring that the correctly sized EcoPure unit is selected for the project based upon the above parameters, there are additional factors to consider when designing a site with an EcoPure unit.

To ensure the product will function as intended, it is crucial to be aware of the internal bypass elevation and required inlet to outlet drop within the unit. Figure 6 (above) displays a cross-section of the EcoPure unit showing key dimensions. The height of the inlet riser being 40" above the vault floor and the outlet invert being 16.75" above the vault floor creates 23.25" of drop required between the inlet and outlet. The permanent pool of water in the pretreatment cell and required driving head from inlet to outlet are important to consider in design, especially when there is detention and/or conveyance upstream. It is also important to consider the height of the bypass standpipe 55" above the floor of the vault, as this is the max depth of ponding prior to bypass being achieved. The designer should be conscious of these parameters to ensure they are specifying a functional unit.

Design Considerations – Bypass

Another constraint to consider in design is the capacity of the bypass pipe. During more severe storm events, it is likely that the treatment rate through the inlet risers will be exceeded which can cause overflow through the bypass pipe. While helpful to a certain degree, the bypass pipe has a capacity of 0.6cfs. This should be considered as flows exceeding both the treatment and bypass flow rates will cause the influent source to back up. If present, this issue can be remedied with the use of an external bypass, which would allow water to continue flowing downstream after flow capacity is reached. Two different options for external bypass are present below.

Offline Site Layout – Curb Inlet

Flows in excess of unit treatment rate diverted to downstream curb inlet via surface flow
*Cleanouts omitted from layout for clarity

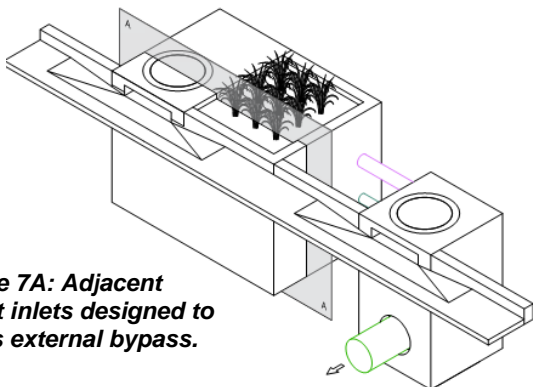

Figure 7A: Adjacent throat inlets designed to act as external bypass.

Offline Site Layout – Pipe Inlet

Flows splitter placed upstream cleanout
*Cleanouts omitted from layout for clarity

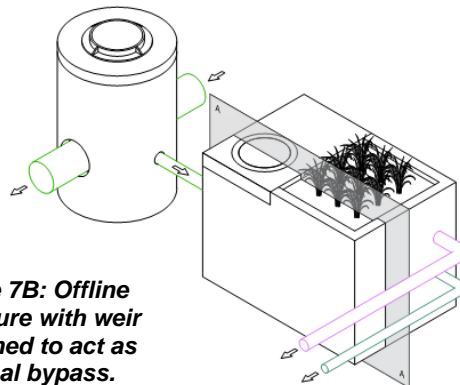

Figure 7B: Offline structure with weir designed to act as external bypass.

Installation

Installation of the EcoPure unit will involve subsurface excavation, placement of sub-base aggregate material, positioning/casting of the vault, and arrangement of the internal components. Proper installation of the unit is crucial to ensure performance in alignment with the parameters specified above. Please refer to the *EcoPure BioFilter Installation Guide* for specifics on how the unit should be installed. Variance from the steps outlined in this document can result in an improperly functioning unit.

Plants

Plants are not required to be utilized but if desired, choice of plant should align with local requirements and/or be chosen by a qualified landscape architect. If guidance is required, ADS can provide a generic plant list for assistance in design. ADS also has planting details for generic guidance. Please refer to local requirements/approvals to determine if plants are required for the EcoPure BioFilter in your area.

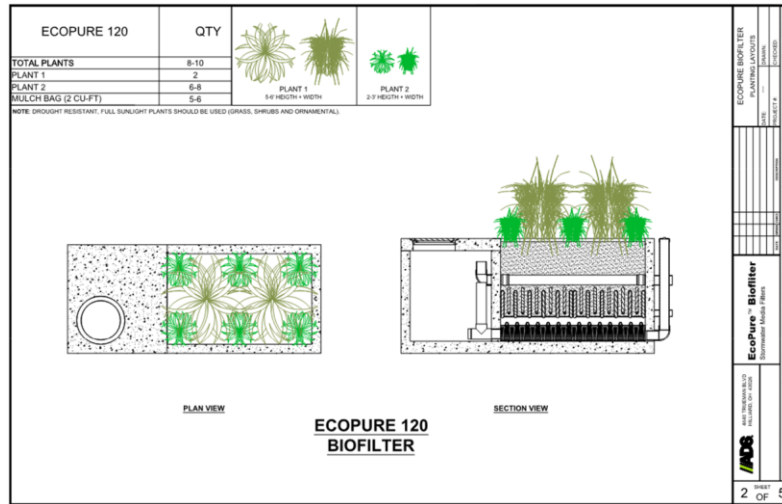

Figure 8: Example plant layout on an EcoPure 120.

