

Technical Note

TN 7.01 Rainwater Harvesting with HDPE Pipe Cisterns

Introduction

For the past several years, the use of smooth interior corrugated high density polyethylene (HDPE) pipe has been a viable alternative for the control of stormwater quality through underground systems. Typically, stormwater has either been infiltrated through perforated pipe or detained in solid pipe and then discharged at a controlled rate to the local storm sewer system or tributary. In both situations, the design did not provide for the potential reuse of stormwater. There is a growing demand for the construction industry to provide for resource reuse. In some situations, the reuse is being driven by a regulatory requirement. In many cases, the reuse of resources can provide an economic benefit. This is especially applicable to stormwater in areas where water resources are at a premium. Water reclamation should be considered in situations where infiltration is not feasible due to site constraints. This document provides information on the installation, storage capacity and system layouts for rainwater harvesting systems using ADS HDPE pipe cisterns.

HDPE Pipe Cisterns

ADS HDPE N-12 pipe is the building block of our cisterns. The Specifications section of the Drainage Handbook provides additional information on pipe dimensions and properties. The pipe has a smooth inner wall and a corrugated outer wall. The smooth inner wall combines superior hydraulics and the ability to resist abrasion and corrosion. The corrugated outer wall provides the strength necessary to withstand heavy traffic loads with varying cover heights. In addition to pipe, the ADS cistern uses specially designed manifolds and other fittings to complete the pipe component of the cistern. ADS can assist with system layout including pipe and necessary components for the cistern.

System Layout

A typical cistern layout includes at least one inlet into the system. This inlet can be on the cistern manifold as shown below or can be done on a lateral. Further, the inlet can be accomplished via a pre-fabricated stub or with a reducer and tee fittings in the system corner. Both inlet types are shown below. When designing system inlets, attention should be given to the hydraulic grade line of the site to limit or prevent conveyance system surcharging.

The outlet of the cistern should be directed to a reinforced concrete manhole. The manhole should be reinforced to limit the effects of vibration from the pump system. The outlet invert should be the same as the pipe invert elevation to ensure that the entire system is able to drain. An underdrain should be installed within the stone backfill of the cistern. The invert of the underdrain should be at the bottom of the stone backfill envelope. The underdrain from the stone backfill should be directed to the outlet manhole so that the stone backfill can be completely drained.

The outlet manhole serves multiple purposes. In addition to acting as an outlet structure, the manhole also houses a discharge pump (designed by others) to remove stormwater from the cistern. Installing a pump within the system piping or pumping directly from piping is not recommended for hydraulic reasons. The manhole should be located outside the footprint of the thermoplastic liner as shown in the detail below.

The outlet manhole will also include the cistern overflow. It is recommended that an overflow be incorporated into the system in the event that the cistern is not completely emptied between storm events. If the cistern is not completely empty and there is no overflow, the potential exists for the entire system to be surcharged and flooding could occur. The invert of the overflow should be set at the top of the cistern.

Lastly, the outlet manhole can also include a vent from the system. System venting is recommended to allow adequate airflow through the cistern and equalize air pressures within the cistern. If not vented, there can be issue with cistern pressures under some circumstances. In the sample layout shown below, the system includes a 4-inch HDPE vent line leading from the cistern to the outlet manhole. To prevent backflow into the cistern through the vent, it is recommended that the vent be located above the crown of the overflow pipe. The use of a vent is recommended for installations in which the cistern is encased within the thermoplastic liner. For cisterns that are not completely encased within the thermoplastic liner, the use of a vent is at the engineer's discretion.

Figure 1
Example Cistern Layout

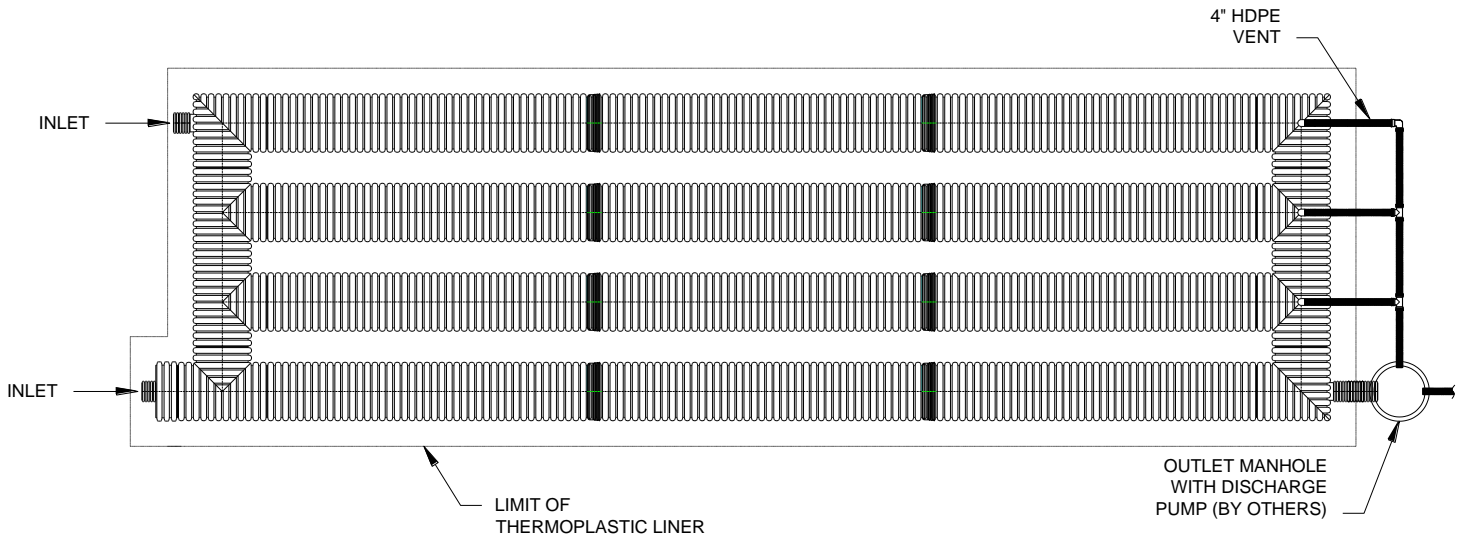
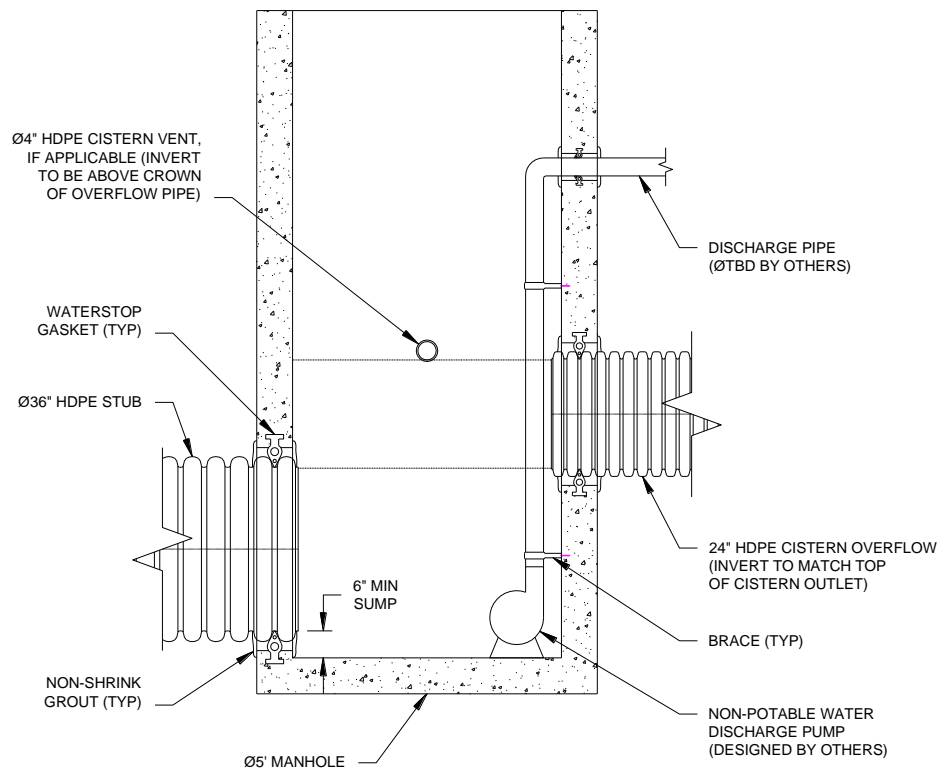

Figure 2
Outlet Manhole Typical Detail



Storage Capacity

ADS cisterns maximize storage capacity by using pipe and stone voids together for total system storage. Table 1 lists storage volume per pipe diameter, stone void volume per pipe diameter and total storage volume for pipe and stone together.

Table 1
Pipe Storage Capacity

Nominal Inside Diameter	Average Outside Diameter	“X” Spacing	“S” Spacing ¹	“C” Spacing ¹	Pipe Volume ²	Stone Void Volume ^{3,4,5}	Total Storage
in. (mm)	in. (mm)	in. (mm)	in. (mm)	in. (mm)	ft ³ /ft (m ³ /m)	ft ³ /ft (m ³ /m)	ft ³ /ft (m ³ /m)
12 (300)	14.5 (368)	8 (200)	11 (279)	25.4 (645)	0.79 (0.07)	1.1 (0.10)	1.8 (0.16)
15 (375)	18 (457)	8 (200)	12 (305)	28.9 (734)	1.2 (0.11)	1.4 (0.13)	2.6 (0.24)
18 (450)	21 (533)	9 (230)	17 (434)	33.9 (862)	1.8 (0.16)	1.7 (0.15)	3.5 (0.32)
24 (600)	28 (711)	10 (250)	13 (330)	40.7 (1034)	3.1 (0.29)	2.6 (0.24)	5.7 (0.52)
30 (750)	36 (914)	18 (450)	18 (457)	53.1 (1347)	4.9 (0.46)	3.7 (0.34)	8.6 (0.79)
36 (900)	42 (1067)	18 (450)	22 (559)	63 (1600)	7.1 (0.66)	4.7 (0.43)	11.8 (1.08)
42 (1050)	48 (1219)	18 (450)	24 (610)	71.9 (1826)	9.3 (0.87)	5.8 (0.53)	15.1 (1.38)
48 (1200)	54 (1372)	18 (450)	25 (1219)	78.5 (1994)	12.4 (1.15)	7.0 (0.64)	19.4 (1.78)
60 (1500)	67 (1702)	18 (450)	24 (1524)	90 (2286)	19.3 (1.79)	9.7 (0.89)	29.0 (2.66)

Notes:

See Figure 3 for typical cross section used in volume calculations

Bedding depth assumed 4” for 12”-24” pipe and 6” for 30”-60” pipe.

1. Based on A-profile pipe.

2. Actual ID values used in calculation.

3. Stone Porosity assumed 40%.

4. Stone height above crown of pipe is not included in void volume calculations.

5. Calculation is based on the average OD of the pipe.

Installation

For a cistern application, ADS N-12 perforated pipe embedded in a Class I crushed stone backfill is recommended. See Figure 3 for minimum recommended cover heights for standard installations. A maximum of 1 ½” aggregate size is preferred and the stone should be clean with no fines. The stone backfill provides two critical elements to the cistern design. First, the stone provides necessary structural support for the system to withstand dead loads and vehicular loading. Secondly, the stone provides a certain void volume which can be incorporated into the total storage volume that the cistern can provide. This can help with the reduction of the cistern size and keep the overall footprint to a minimum.

Up to this point, the design is no different than the traditional ADS HDPE pipe infiltration system. The traditional infiltration system would include the use of a geotextile to separate the stone backfill from the native material. For a cistern, a thermoplastic liner shall be used in place of the geotextile as shown in Figure 1. The liner will maintain the water tight integrity of the cistern and hold the stormwater in place before it is reclaimed. Because of the use of a thermoplastic liner, installation of cisterns below groundwater is not recommended due to potential issues with buoyancy and hydrostatic head. To prevent issues with groundwater, an underdrain can be placed under the liner so long as gravity discharge is available. Additional consultation with a geotechnical engineer may be necessary to address groundwater concerns.

Figure 3
Typical Cistern Cross Section

Note: This is a typical cross section only. See Structures, Section 2, or Installation, Section 5, of the Drainage Handbook for specific installation guidelines.

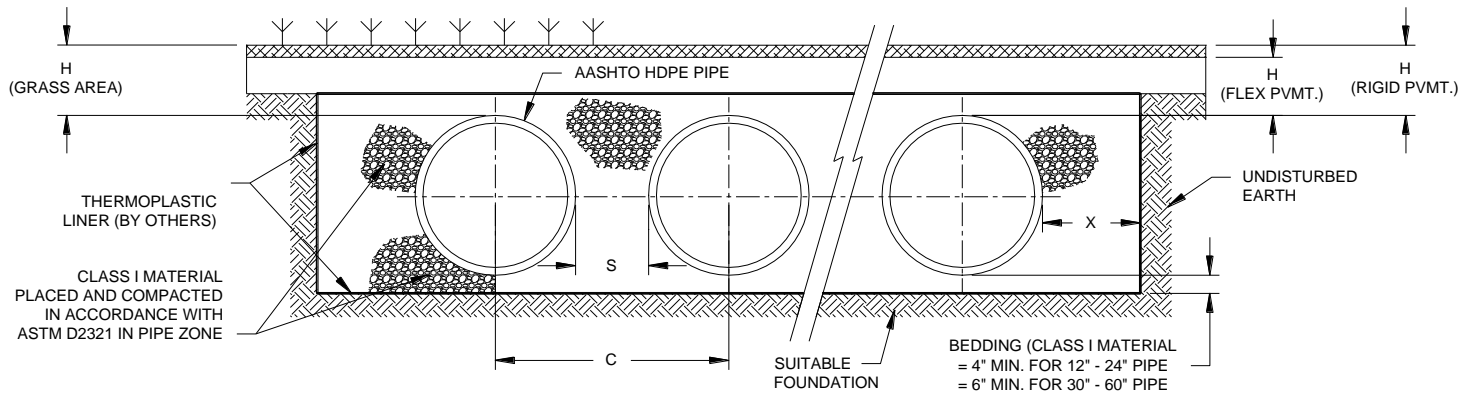

Thermoplastic Liner

ADS does not design, fabricate, install or sell thermoplastic liners. The following product details are based on information supplied and published by thermoplastic liner manufacturers. Generally speaking, there are two liner materials that are suitable for this application: polyvinyl chloride (PVC) and linear low density polyethylene (LLDPE). PVC liners are easy to install making it a low cost alternative. Some PVC liners contain fillers and plasticizers. Under prolonged exposure to sunlight, these compounds can leach from the liner. With use in a cistern application, exposure from sunlight is not a concern since the system is located underground. The LLDPE is an inert material that is suitable for the storage of stormwater and would be acceptable for this application. Medium and high density liners are also available but are not as flexible as the low density product and are typically higher in cost.

For any liner, puncture resistance needs to be considered. This can be addressed by the placement of non-woven geotextile on either side of the membrane. The liner seam, if applicable, should be watertight to maintain the integrity of the system. Pipe "boots" need to be pre or field fabricated for locations where system piping is either entering or exiting the cistern footprint, i.e. inlet and outlet piping. A detail depicting the liner "boot" is shown as Figure 4. The other factor that needs to be considered when using a thermoplastic liner is the seasonal high water table. High water tables can create excessive hydrostatic pressure and potentially damage the liner.

**Figure 4
Liner Pipe Connection Detail**

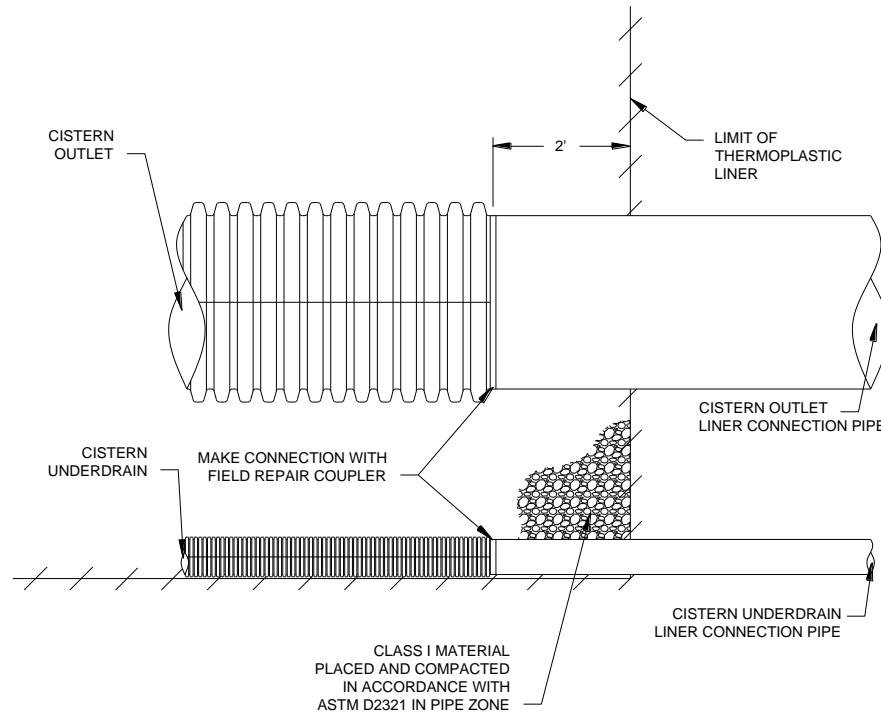

NOTES:

1. CONNECTIONS OF PIPE TO THERMOPLASTIC LINER SHALL BE MADE AT THE DIRECTION OF LINER MANUFACTURER.
2. CISTERN LINER CONNECTION PIPE SHALL BE CONNECTED DIRECTLY TO OUTLET STRUCTURE.
3. CISTERN PIPE SHALL BE CONNECTED TO LINER CONNECTION PIPE WITH FIELD REPAIR COUPLER.

Installation of liners should be in accordance with the manufacturer’s recommendations. ADS recommends consulting with the liner manufacturers for final design, installation and cost information regarding the liner component of the cistern design.

Cistern Design

Due to the similarity of the cistern to an infiltration system, the ADS Retention/Detention Calculator can be used to size the pipe, fittings and stone component of the cistern. The Calculator can be accessed via the ADS website at www.ads-pipe.com.

The required bed size is indicated in the excavation section of the Calculator. The required amount of thermoplastic liner can be calculated from these bed dimensions as follows:

$$((H * L * 2) + (H * W * 2) + (L * W * 2)) = \text{required amount of liner in square feet}$$

where:

- H = height of cistern section
- L = length of cistern section
- W = width of cistern section

This calculation is based on a design in which the cistern is completely encased within the thermoplastic liner which is at the engineer's discretion. In the event that the system is not completely encased and the liner extends below and along the sides of the cistern, the calculation is as follows:

$$((H * L * 2) + (H * W * 2) + (L * W)) = \text{required amount of liner in square feet}$$

where:

H = height of cistern section

L = length of cistern section

W = width of cistern section

Technical Assistance

Throughout cistern design, ADS can assist with a variety of technical issues on the use of our HDPE pipe and fittings, including:

- Product performance information and suggested product usage
- Manifold pipe configuration and design
- Number and spacing of system laterals (based on provided design storage)
- Existing product modifications; custom product fabrication
- Suggestions to maximize cost effectiveness

Please contact an ADS representative for further information.

Note: The use of cisterns is not recommended as a fire suppression source due to impact of weather variations on water supply and ultimately availability.

