

DUAL WALL FABRICATED MITERED 90° BENDS
12" - 18" DIAMETER

PART #	PIPE SIZE	A	B	JOINT
1299AN	12 in (300 mm)	9.4 in (239 mm)	7.8 in (198 mm)	*
1299AN65B	12 in (300 mm)	5.5 in (140 mm)	7.8 in (198 mm)	WT
1599AN	15 in (375 mm)	12.1 in (307 mm)	9.3 in (236 mm)	*
1599AN65B	15 in (375 mm)	6.9 in (175 mm)	9.3 in (236 mm)	WT
1899AN	18 in (450 mm)	12.2 in (310 mm)	10.0 in (254 mm)	*
1899AN65B	18 in (450 mm)	7.1 in (180 mm)	10.0 in (254 mm)	WT

* = PLAIN END
ST = SOIL TIGHT
WT = WATER TIGHT

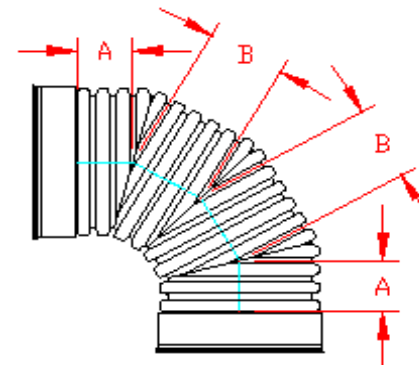
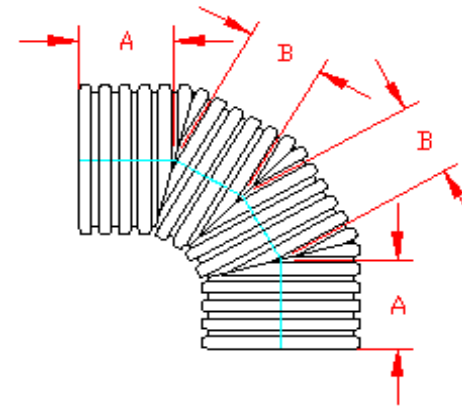

NOTE: ALL FITTINGS DIMENSIONS ARE FOR REFERENCE ONLY

© 2023 Advanced Drainage Systems, Inc.



DRAWING #:	2220	
DRAWN BY:	JCB	04.06.06
APPROVED BY:	JCB	06.25.07
REVISIONS:	TJR	4/26/2016