

FlexStorm Pure™ Replacement Bag Maintenance Guide

After following the FlexStorm Operation and Maintenance Guide and performing routine maintenance, you may notice damage or degradation of the inlet filter's geotextile bag. This will require replacement of the geotextile bag portion of your inlet filter device. FlexStorm Pure™ (permanent) has replacement bags. If a FlexStorm Lite™ (temporary) filter is damaged, please replace the entire filter unit.

Sizing the Replacement Bag

Option 1: Check the Label

Locate the inlet filter's label attached on the inside visible perimeter of the existing filter frame.

Note the bag size and style listed:
(###" x ##" & STYLE)

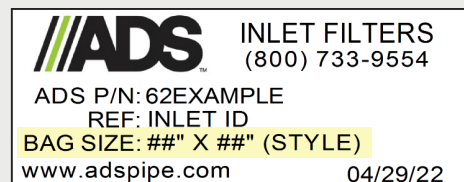

Option 2: Take Measurements

If the label cannot be located, remove the filter from the inlet and take off the existing bag. Measure the length and width of the frame perimeter that holds the bag's hose clamp as shown on the right.

Note: If the filter is round provide the outer diameter of the bottom framing channel.

It is necessary to also provide the bag style that was originally provided on the filter. Pure filters have a variety of options available for replacement bags pertaining to treatment properties required ("FX" or "PCP").

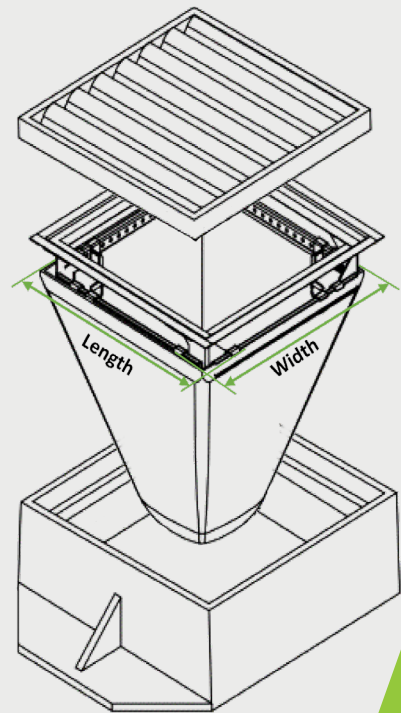

Sediment Bag Replacement

1. Remove the bag by loosening or cutting off the clamping band.
2. Take the new, correctly sized geotextile bag and secure the hose clamping band to the frame channel as previously removed.
3. Ensure the bag is secure and there is no slack around perimeter.

