

Technical Note

TN 6.33 Utilizing StormTech® Chambers for Stream Crossings

Introduction

StormTech chambers offer the distinct advantage and versatility that allow them to be designed as open bottom stream crossings for low flow applications. Open bottom culverts using chambers are best suited for natural stream beds in low velocity water ways that support local wildlife crossings. *Open bottom culverts are highly susceptible to scour. By utilizing good design practices and scour protection measures they can be a viable option for low velocity waterways. StormTech does not recommend using the chambers where velocities in the channel are high enough to mobilize rocks and large debris which could become projectiles that can damage the chambers.*

Culvert design involves many site specific and regulatory constraints that necessarily leave overall design responsibility with the design engineer including whether an open bottom culvert is the correct solution for the project. Due to the complex nature of culvert design and the design being very dependent on specific site conditions, this document is provided for design engineers to use as general guidance only when specifying StormTech chambers as open bottom culverts. The references/resources listed at the end of this Tech Sheet provide more specific engineering design information.

Chambers should not be used as common conveyance culverts since typical culvert flows can easily exceed scour velocities even with scour prevention measures in place.

General

The design engineer must understand the application and the consequence of failure. This understanding then drives the hydraulic design flood frequency and a corresponding scour design flood frequency. With this information, the design engineer can design the appropriate scour prevention measures or determine if an open bottom stream crossing is a viable option for the specific project. Culvert design software can be used to determine flow, velocity and flow depth inside the chamber. To model chambers using culvert design software, contact ADS Engineering Services at (888) 892-2694 for inputs that can be used in FWHA's HY-8 software. See Appendix C.

StormTech chambers come in 5 sizes with outside widths ranging from 25" to 100" with corresponding open spans of 15 to 85 inches, allowing the design engineer a wide variety of choices for their project.

Figure 1 below shows the four largest StormTech chambers with dimensions on rise and span and open area (do to it size the SC-160 is not included as it would not make a viable stream crossing). For additional dimensions and limits on maximum and minimum cover depths, see the StormTech Product Catalog or StormTech design manuals.

Figure 1
Chamber Dimensions and Open Area

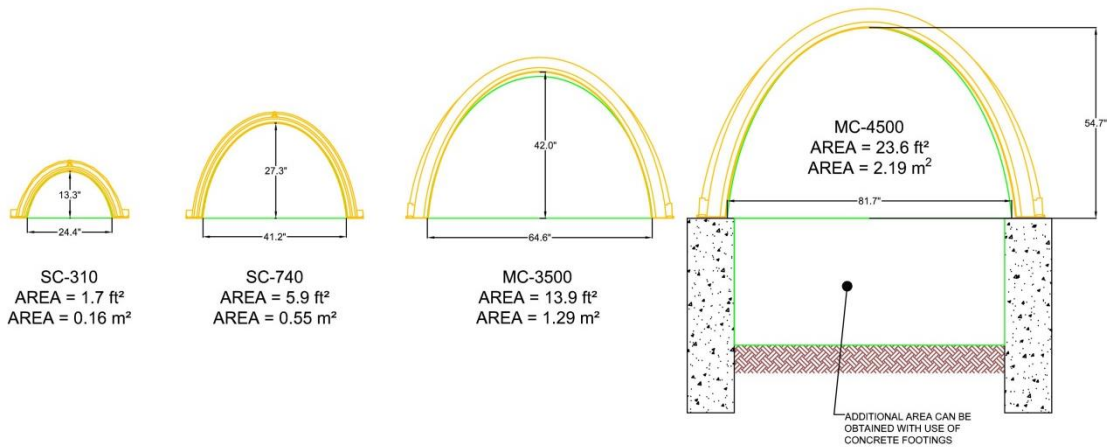

Design Considerations

There are four basic design considerations: 1) structural design and cover depth 2) design of footings or foundation 3) design of clear opening and alignment and 4) design of scour prevention. These design considerations are not independent. For example, alignment might impact scour, cover depth might impact footing design and footing design might impact clear opening.

Structural Design

Generally, structural design simply means that StormTech specifications for proper embedment, fill materials and installation details are specified and followed. Note that the StormTech chambers require stone above and on the sides of the chambers. See the StormTech Design Manuals for stone requirements and cover requirements. Maximum and minimum cover depths are also specified for each chamber model. When footings are used under the feet of the chamber, it is important that the footing width extend beyond the chamber feet at least the width of the normally specified perimeter stone column which is 12" for all chambers. Since the structural performance of the chamber is dependent upon stiffer materials surrounding the chamber relative to the flexible chamber, it is important to establish a proper load path to the stiff footing. In other words, if the chamber feet were on a stiff concrete footing and the load path through the surrounding stone terminated in a soft subgrade, the chamber would experience higher loads than intended.

Chamber Foundations and Footings

StormTech chambers require a stable foundation to support the feet of the chamber and to spread load to the subgrade soils. When chambers are used for stormwater storage applications, the foundation consists of compacted, crushed stone and the required depth of foundation stone is dependent upon cover height and bearing capacity of the underlying soils. For open bottom culvert applications, typical foundation stone might be erodible or in other cases, a natural stream bottom may be required. Therefore, the foundations for chambers in open bottom culvert applications are often special footing designs. The footing design should ensure a non-erodible base and should distribute the load from the feet of the chamber and the surrounding stone columns to the underlying soils based on the bearing capacity of the underlying soils. Figure 2 shows four possible foundation / footing designs.

Figure 2
Footing Design Examples for StormTech Chambers

CONCRETE FOOTING OPTION 1:
 OPEN BOTTOM (FOR VERY LOW
 FLOW APPLICATIONS)

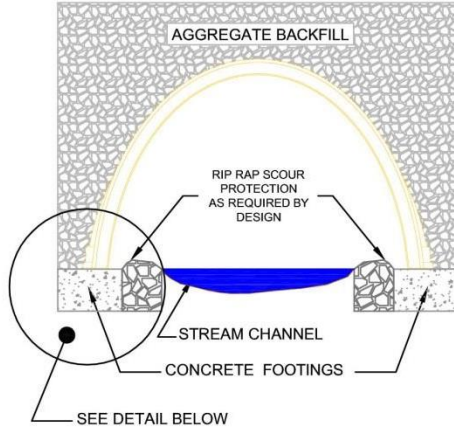

CONCRETE FOOTING OPTION 2:
 AGGREGATE BOTTOM
 (FOR LOW FLOW APPLICATIONS)

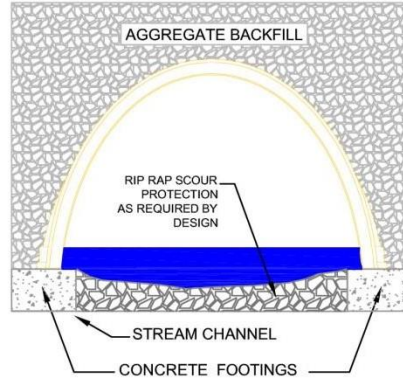

AGGREGATE FOOTING OPTION 1:
 OPEN BOTTOM (FOR VERY LOW
 FLOW APPLICATIONS)

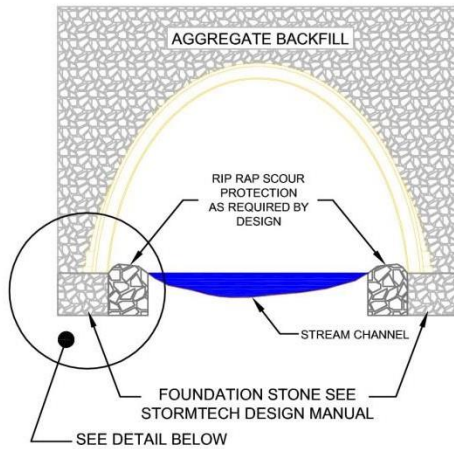

AGGREGATE FOOTING OPTION 2:
 AGGREGATE BOTTOM
 (FOR LOW FLOW APPLICATIONS)

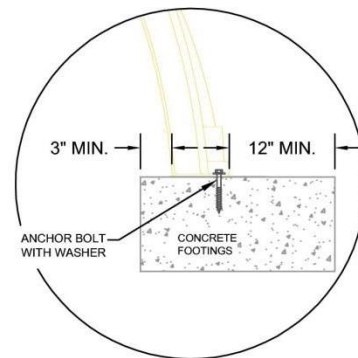
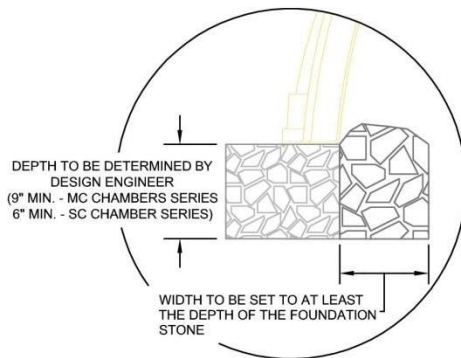
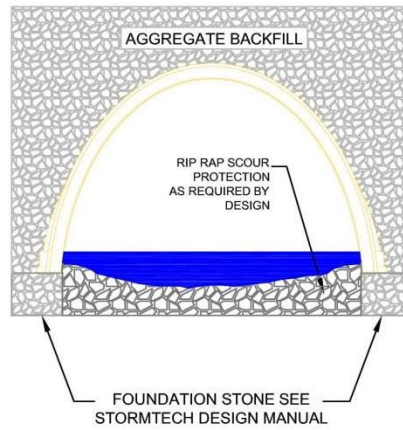

Concrete footings can be poured in place or concrete blocks. The top width of the footing should extend at least 3 inches on the inside of the chamber foot and 12" on the outside of the chamber foot. Chamber foot widths vary from 4" to 8" depending on model resulting in minimum footing top widths of 19" to 23". Footings shall be set to within 2" of level from side to side. Footings shall be continuous along each side of the chamber row. Adjacent blocks shall be set to within 1/4" of each other in top elevation and within 1/2" separation. The chamber feet must be fixed to the footings with four 5/16" diameter (min) anchor bolts per chamber or restrained with a "keyway" in the top of the footing. (Figure 3) The bottom width of the footing must be based on the bearing capacity of the underlying soils. See Appendix A.

Figure 3
Anchor Bolt Placement

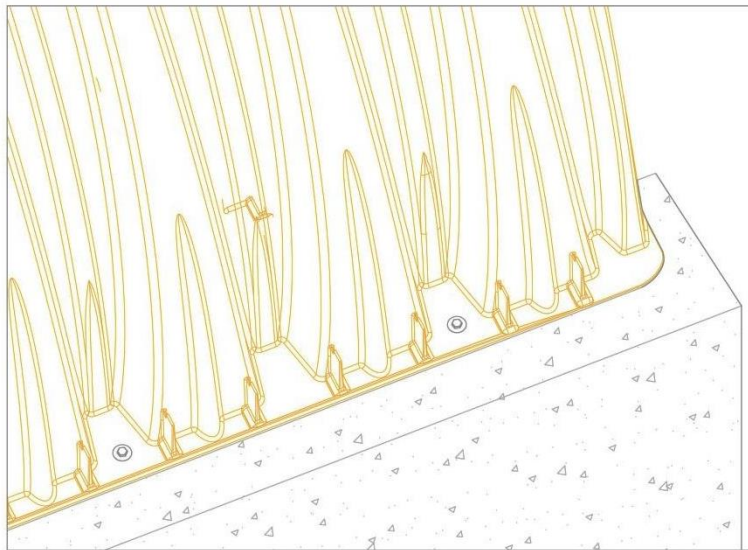

Design for Clear Opening

The clear rise, span and corresponding openings for each StormTech chamber can be found in Figure 1. These values are representative of the bare chamber or chamber based on a flat foundation. By placing the feet of the chambers on footings nearly the entire inside width of the chambers can be left as an open bottom crossing. This open bottom allows for less disruption to the natural substrate within the stream bed. Maintaining the natural substrate within the stream bed is also ideal for aquatic organism and amphibian passage, as the natural bed promotes stream continuity and transport, enabling a safe crossing under roadways. Elevating the feet of the chambers above the stream bed on concrete footings also increases the openness ratio when being used as a critter crossing.

Scour Design

The design engineer must ensure the water velocities through the open bottom culvert do not exceed the permissible velocities of the culvert. When designing an open bottom culvert there are several locations that must be analyzed for potential scour. These include, but are not limited to: inlet scour, contraction scour, scour of the stream bed material down the length of the culvert and the exit scour. The Federal Highway Administration sponsored two studies of open bottom culverts that detail these scour concerns (Kerenyi, Jones and Stein, 2003 and Kerenyi, Jones and Stein, 2007).

The greatest potential for scour may be contraction scour at the upstream corners of the culvert entrance (see Figure 4). Proper headwall and rip-rap design are important ways to handle inlet and contraction scour. HEC-23 Design Guideline 18 provides details and design guidelines for rip-rap designs for open bottom culverts. The actual scour protection measures will be site specific by the site design engineer based upon the chamber selected, design flow/velocities and headwall design.

HEC 18 provides guidance on the elevation/depth of the footings based on scour and site-specific criteria. Part of this guidance suggests the top of the footing should be below the sum of the long-term degradation, lateral migration and contraction scour. Based on the hydraulic design and scour potential the design engineer has several options for the footing of the StormTech chambers. The design engineer must determine which scour prevention measures to utilize between the footing/feet based on the design flow rates and site-specific conditions.

Designs that see moderate to high flows and/or are inlet flow controlled designs can easily exceed the scour limits of natural stream bottoms/rip rap designs. **It is not recommended to utilize StormTech chambers for these types of culverts/stream crossing.** Table 1 lists some permissible shear velocities for various size materials. Design engineer can use this table as a reference to determine if the anticipated design flows produce velocities that approach the bottom material scour limits. Note that there are additional scour concerns other than just shear velocities. See Appendix B for a design example.

**Figure 4
Contraction Scour**

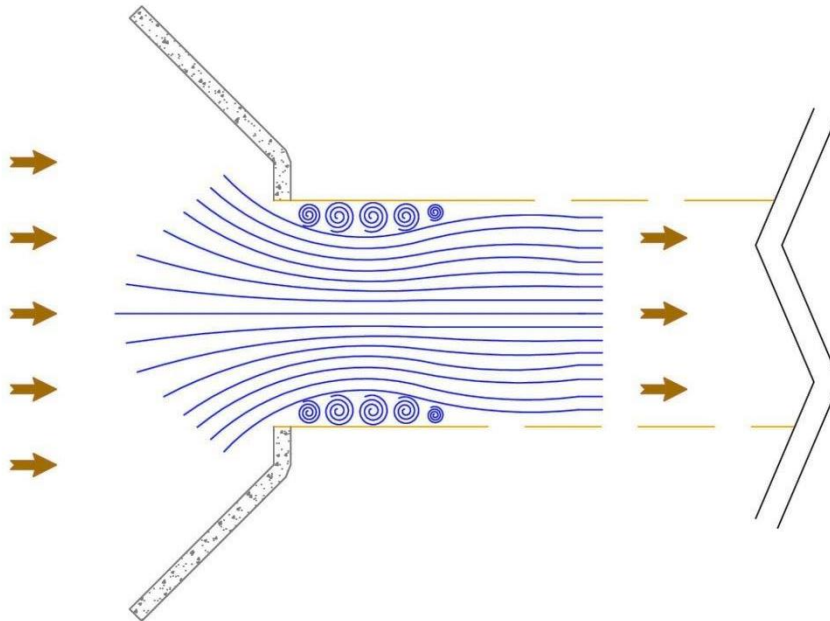

Table 1 is a reference for engineers to utilize for permissible shear velocities for various types of materials that may be part of an open bottom passing.

Table 1
Permissible Shear Velocities

Material	N	Clear Water		Water Transporting Colloidal Silts	
		U (ft/s)	τ_0 (lbs/ft ²)	U (ft/s)	τ_0 (lbs/ft ²)
Fine sand, colloidal	0.020	1.50	0.027	2.50	0.075
Sandy loam, noncolloidal	0.020	1.75	0.037	2.50	0.075
Silt loam, noncolloidal	0.020	2.00	0.048	3.00	0.11
Alluvial silts, noncolloidal		2.00	0.048	3.50	0.15
Ordinary firm loam	0.020	2.50	0.075	3.50	0.15
Volcanic ash	0.020	2.50	0.075	3.50	0.15
Silt clay, very colloidal	0.025	3.75	0.26	5.00	0.46
Alluvial silts, colloidal	0.025	3.75	0.26	5.00	0.46
Shales and hardpan	0.025	6.00	0.67	6.00	0.67
Fine gravel	0.020	2.50	0.075	5.00	0.32
Graded loam to cobbles when noncolloidal	0.030	3.75	0.38	5.00	0.66
Graded silts to cobbles when colloidal	0.030	4.00	0.43	5.50	0.80
Coarse gravel, noncolloidal	0.025	4.00	0.30	6.00	0.67
Cobbles and shingles	0.035	5.00	0.91	5.50	1.10

A sample open bottom crossing design with a bearing capacity check and scour considerations is shown in Appendix A and B.

References/Resources

Federal Highway Administration, 2012, "Evaluating Scour at Bridges," Hydraulic Engineering Circular 18, 5th Edition, Report No. FHWA-HIF-12-003-HEC-18

Federal Highway Administration, 2009, "Bridge Scour and Stream Stability Countermeasures: Experience, Selection, and Design Guidance," Hydraulic Engineering Circular 23, 3th Edition, Volume 2, Publication No. FHWA-NHI-09-112

Federal Highway Administration, 2007, "Bottomless Culvert Scour Study: Phase II Laboratory Report," Report No. FWHA-HRT-07-026 (Kerenyl, K., J.S. Jones, and S. Stien)

Federal Highway Administration, 2003, "Bottomless Culvert Scour Study: Phase 1 Laboratory Report," Report No. FWHA-RD-07-78 (Kerenyl, K., J.S. Jones, and S. Stien)

Appendix A

Sample open bottom crossing design:

The application requires an open area of 30 square feet for a critter crossing under a proposed gravel driveway. The engineer would like to use an MC-4500 chamber which has an open area of 23.6 square feet. By putting the MC-4500 chamber on 12" tall footings, an open area of approximately 30 square feet can be achieved. To minimize the embankment fill for the driveway, the engineer wants minimum cover over the chambers which StormTech specifies as 24" for the MC-4500 chamber. The insitu parent soils are described as fine to medium compact silty sand.

The engineer specifies that the StormTech MC-3500 and MC-4500 Design Manual is to be followed. This provides dimensions and specifications on allowable embedment materials, fill materials and separation fabric. The foot of the MC-4500 chamber is approximately 8 inches wide. Allowing 3" from the inside of the chamber foot to the inside of the footing and 12" outside the chamber foot results in a total footing top width of 23 inches. Consider 24" wide by 12" tall concrete blocks as footings.

A proper chamber design has already been assured by requiring installation in accordance with the StormTech Design Manual. The remaining tasks are: 1) to check the bearing capacity of the underlying soils and the footing width to ensure a stable base and 2) to determine what, if any, scour control measures are necessary.

Figure 3
Bottom Crossing Design

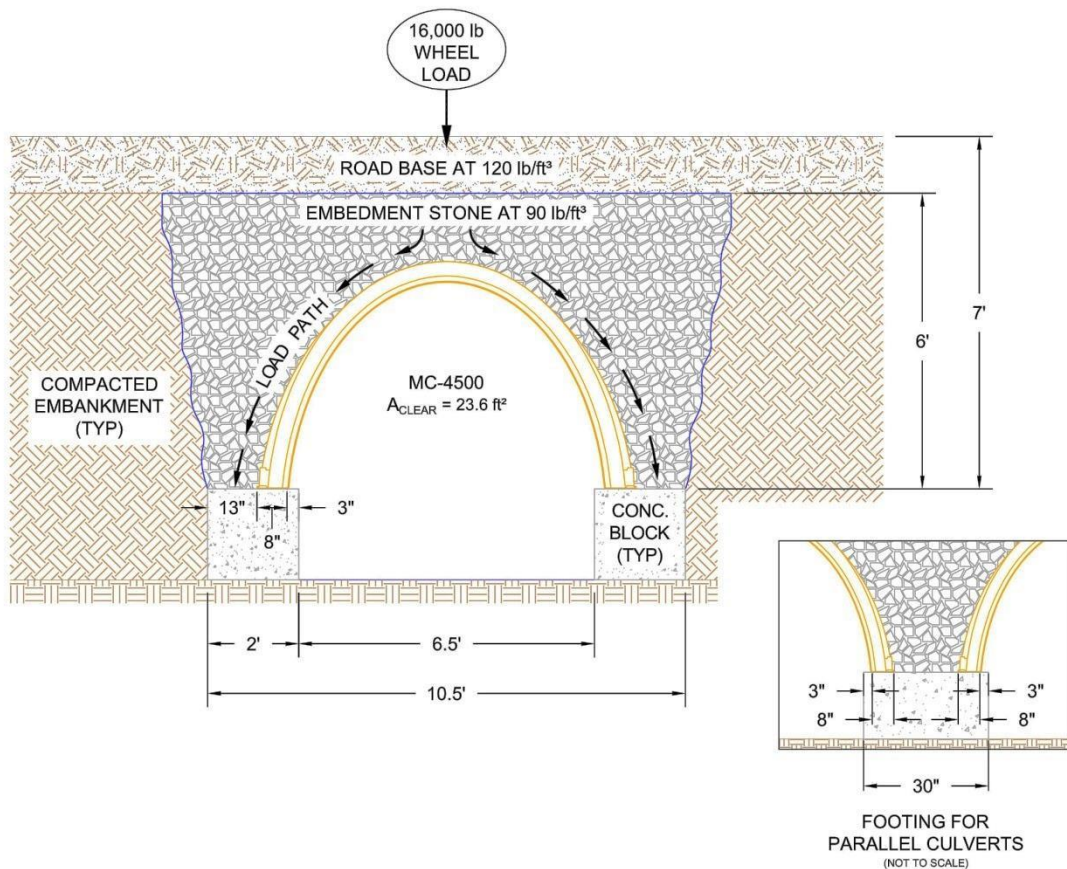

Bearing Capacity / Footing Design

To evaluate the footings, calculate the total live and dead load on the footings, divide it over the bottom area and compare it with the bearing capacity of the underlying soils.

Use AASHTO design load criteria:

Live load: 16,000 lb wheel over 10" by 20" wheel patch (AASHTO Design Truck)
Apply multiple presence factor of 1.2 = 19,200 lbs
Apply a dynamic impact factor for 24" cover of 1.25 = 24,000 lbs
Divide total live load by 2 for load on each footing = 12,000 lbs

Determine "out of plane" load distribution. This would be load spread along the length of the chamber. Use the 10" dimension to be conservative and spread the wheel load through 24" of cover at the AASHTO rate of 1.15h where h = 24". L = 10" + 1.15(24) = 37.6". Use 3 ft

$$12,000 \text{ lbs} / (2 \text{ ft wide footing} \times 3 \text{ ft length out of plane}) = 2000 \text{ lbs/sqft at bottom of footing}$$

Dead load: Road base = $1 \text{ ft} \times 10.5 \text{ ft} \times 120 \frac{\text{lbs}}{\text{cuft}} = 1,260 \frac{\text{lb}}{\text{ft}}$

$$\text{Embedment stone} = ((6 \text{ ft} \times 10.5 \text{ ft}) - 26.5 \text{ sqft}) \times 90 \frac{\text{lbs}}{\text{cuft}} = 3285 \frac{\text{lb}}{\text{ft}}$$

$$\text{Concrete footings} = 1 \text{ ft} \times 2 \text{ ft} \times 150 \frac{\text{lbs}}{\text{cuft}} = 300 \frac{\text{lbs}}{\text{ft}}$$

$$\frac{(1260 \frac{\text{lb}}{\text{ft}} + 3285 \frac{\text{lb}}{\text{ft}})}{(2 \text{ chamber feet} \times 2 \text{ ft wide footing})} + \frac{300 \frac{\text{lbs}}{\text{ft}}}{2 \text{ ft wide footing}} = 1286 \frac{\text{lbs}}{\text{sqft}} \text{ at bottom of footing}$$

Total pressure at bottom of foot = 2000 lbs/sqft + 1286 lbs/sqft = 3286 lbs/sqft. Since this is a gravel driveway, the engineer may choose to use presumptive allowable bearing capacity from various sources rather than hire a geotechnical engineer to determine an allowable bearing capacity. For a fine to medium compact silty sand the US Army COE, No 7 "Bearing Capacity of Soils" shows a Nominal Allowable Bearing Pressure of 5000 PSF. Therefore the footing is wide enough.

Appendix B

Design Example

The crossing is designed primarily as a critter crossing but will experience flow from storm events. A drainage area of 20 acres is defined as a minor culvert and sized to the 25 year storm. Using Unit Hydrograph software a Tc of 150 minutes and CN of 66 the drainage area produces a 25 yr flow of 10 cfs.

The Federal Highways HY-8 software was utilized to calculate the velocities. The velocities are checked to ensure the correct scour preventative measures are incorporated into the design. For this design a rip rap will be placed down the length of the crossing.

The following inputs were entered into the software for the MC-4500 chamber:

Design Flow – 10 cfs
Channel Type – Rectangular
Tailwater Width – 8.5 ft
Downstream Manning's n – 0.025
Inlet Invert – 100
Outlet Invert – 99.5
Square Edge Headwall
Span – 6.81 ft*
Bottom Manning's n – 0.035 (Cobbles and Shingles)
Rise – 4.56 ft*
Top/Sides Manning's n – 0.022 (Corrugated)
*See Appendix C for detail input data for StormTech Chambers
Length – 25 ft

With this data the crossing was analyzed and the following information was calculated:

Normal Depth – 0.035 ft
Critical Depth – 0.40 ft
Tailwater Depth – 0.48 ft
Outlet Velocity – 4.01 ft/s
Tailwater Velocity – 2.98 ft/s (To be checked against allowable velocities of the downstream channel)

The outlet velocities are shown to be below the permissible shear velocities listed in Table 1 for gravel and Rip Rap (cobbles) of 4 and 5 ft/s.

Appendix C

Values for entering chamber shape into HY8 software under "User Defined Culvert Shape"

MC-4500 USER DEFINED SHAPE			
NUMBER	X (FT)	Y-TOP (FT)	Y-BOTTOM (FT)
1	0	0	0
2	0.3833	0.1792	0
3	0.7583	2.6500	0
4	1.1330	3.2500	0
5	1.5167	3.6920	0
6	1.8920	4.0250	0
7	2.2750	4.2670	0
8	2.6500	4.4330	0
9	3.0250	4.5250	0
10	3.4080	4.5580	0
11	3.7830	4.5250	0
12	4.1667	4.4330	0
13	4.5420	4.2670	0
14	4.9170	4.0250	0
15	5.3000	3.6920	0
16	5.6750	3.2500	0
17	6.0580	2.6500	0
18	6.4330	1.7920	0
19	6.8080	0	0

Figure 4
MC-7200 User Defined Shape

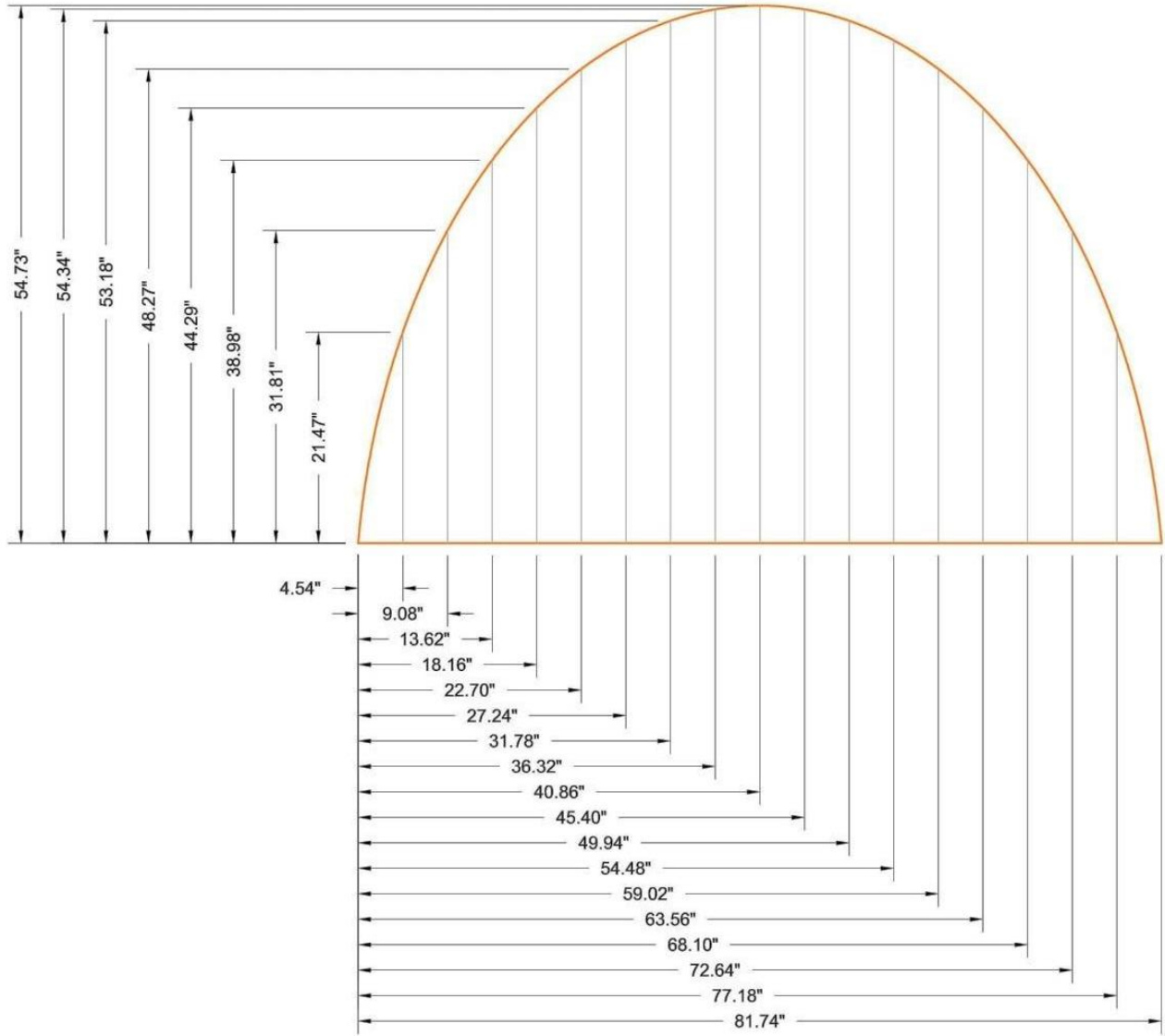

MC-3500 USER DEFINED SHAPE			
NUMBER	X (FT)	Y-TOP (FT)	Y-BOTTOM (FT)
1	0	0	0
2	0.300	1.367	0
3	0.600	2.000	0
4	0.900	2.433	0
5	1.200	2.758	0
6	1.500	3.000	0
7	1.792	3.175	0
8	2.092	3.300	0
9	2.392	3.367	0
10	2.691	3.392	0
11	2.992	3.367	0
12	3.292	3.300	0
13	3.592	3.175	0
14	3.892	3.000	0
15	4.192	2.758	0
16	4.492	2.433	0
17	4.783	2.000	0
18	5.083	1.367	0
19	5.383	0	0

Figure 5
MC-3500 User Defined Shape

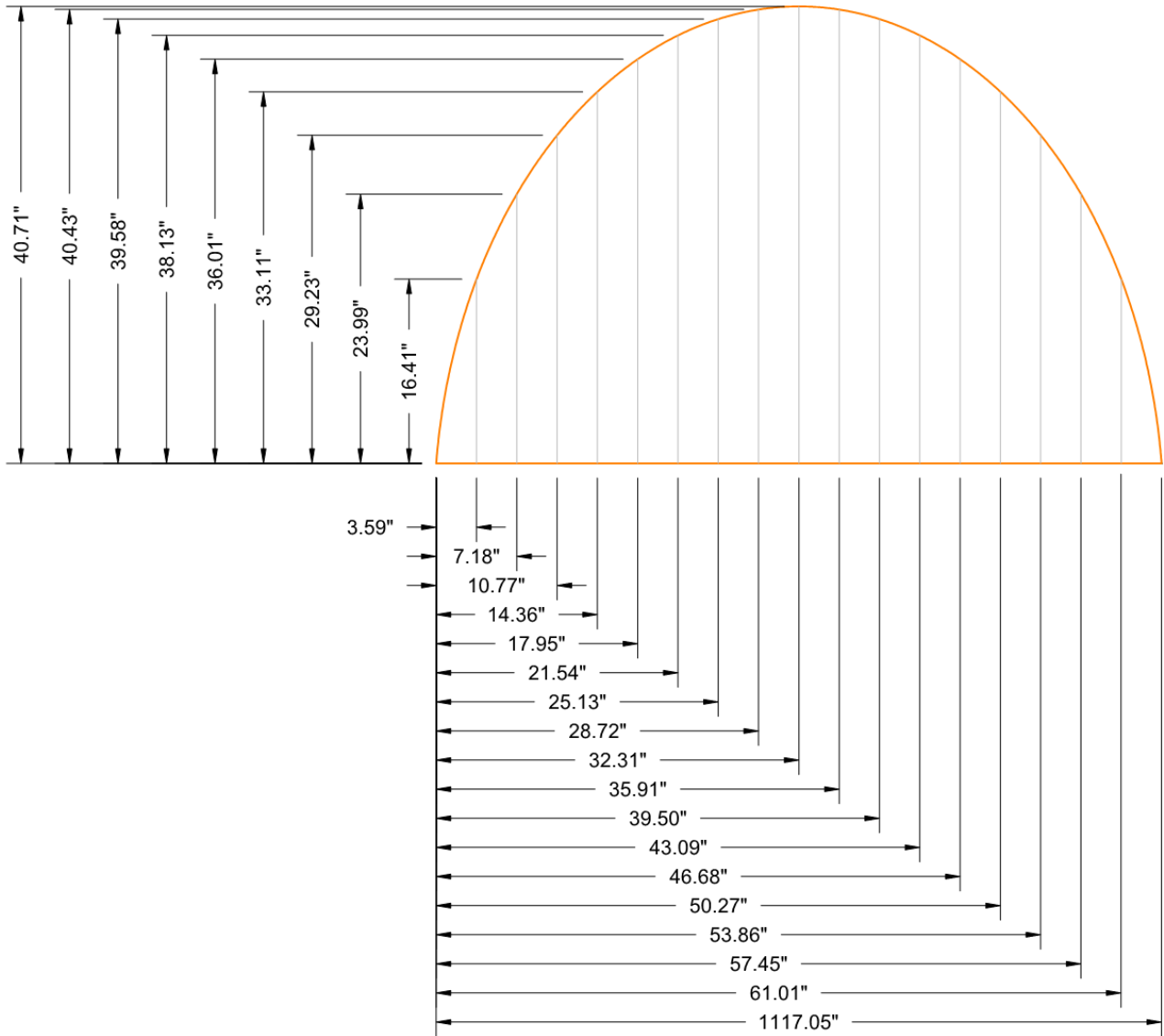

SC-740 USER DEFINED SHAPE

NUMBER	X (FT)	Y-TOP (FT)	Y-BOTTOM (FT)
1	0	0	0
2	0.192	0.875	0
3	0.383	1.308	0
4	0.575	1.617	0
5	0.767	1.833	0
6	0.958	2.008	0
7	1.150	2.125	0
8	1.342	2.208	0
9	1.533	2.258	0
10	1.725	2.275	0
11	1.917	2.258	0
12	2.108	2.208	0
13	2.300	2.125	0
14	2.500	2.008	0
15	2.692	1.833	0
16	2.883	1.617	0
17	3.075	1.308	0
18	3.267	0.875	0
19	3.458	0	0

Figure 6
SC-740 User Defined Shape

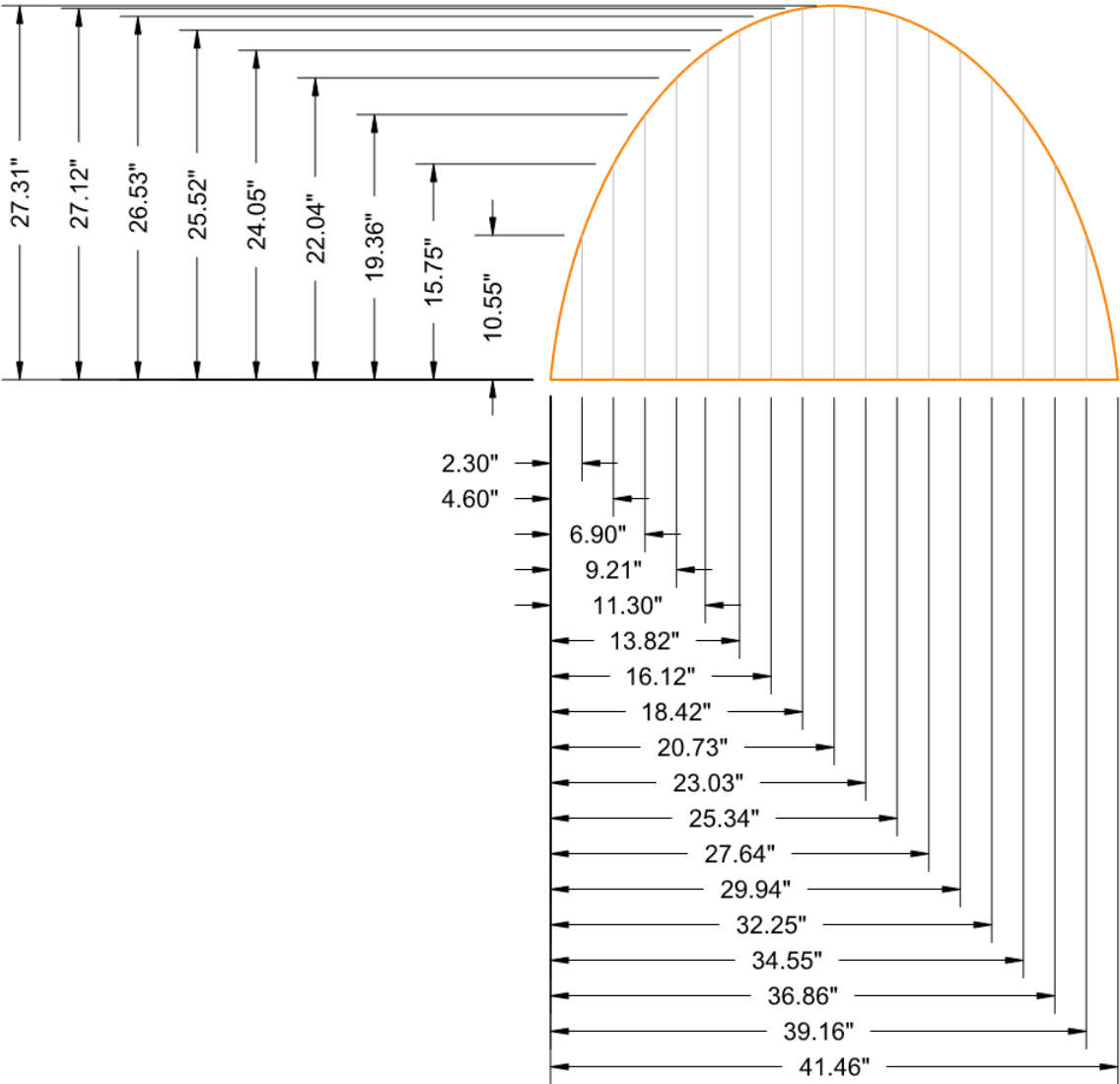

SC-310 USER DEFINED SHAPE

NUMBER	X (FT)	Y-TOP (FT)	Y-BOTTOM (FT)
1	0	0	0
2	0.114	0.381	0
3	0.228	0.603	0
4	0.342	0.760	0
5	0.456	0.878	0
6	0.570	0.968	0
7	0.684	1.033	0
8	0.798	1.078	0
9	0.912	1.104	0
10	1.026	1.113	0
11	1.140	1.104	0
12	1.254	1.078	0
13	1.368	1.033	0
14	1.482	0.968	0
15	1.596	0.878	0
16	1.710	0.760	0
17	1.824	0.603	0
18	1.938	0.381	0
19	2.052	0	0

Figure 7
SC-310 User Defined Shape

