

## 48" Polypropylene Basin Specification

### GENERAL

This specification describes the 48" Polypropylene Basin for use in underground storm water applications as indicated on the contract drawings and referenced within the contract specifications. The ductile iron grates for each of these fittings are to be considered an integral part of the surface drainage inlet and shall be furnished by the same manufacturer.

### MATERIALS

The 48" Polypropylene Basin bodies shall be made from an impact modified copolymer polypropylene meeting the material requirements of ASTM F2764. The joint tightness shall conform to ASTM D3212 for joints for drain and sewer plastic pipe using flexible elastomeric seals. The flexible elastomeric seals used for the polyethylene cone and pipe connections to the structure shall conform to ASTM F477.

The reducing plate, covers, grates and frames furnished for all 48" Polypropylene Basin surface drainage inlets shall be ductile iron. Ductile iron castings used shall conform to ASTM A536 grade 70-50-05 for ductile iron and shall be painted black.

### INSTALLATION

The maximum burial depth of the 48" (1200 mm) HP Polypropylene Basin is 15' (4.6 m) with the use of Class I compacted material as defined in ASTM D234. Excavate Polypropylene Basin location to the depth required and provide a stone base. Stone base shall be a minimum of 6" (150 mm), however a thicker base may be required. A geotechnical engineer shall be contacted to determine adequate bedding specifications. Set Polypropylene Basin in place and level structure. Connect storm pipe into Polypropylene Basin. Re-check Polypropylene Basin depth, level and position. The backfill material shall be crushed stone meeting the requirements of Class I material as defined in ASTM D2321. Bedding and backfill shall be well placed and compacted uniformly in accordance with ASTM D2321. All 48" HP Polypropylene Basins are custom made to order as specified. The maximum depth is 15' (4.6 m). Contact ADS Technical Services for burial depths greater than 15' (4.6 m) or where groundwater will be encountered. The frame and grate/cover must be fully supported by a reinforced concrete collar as designed by others. The concrete collar must extend no less than 18" (450 mm) from the edge of the frame in all directions. The collar must bear on the surrounding stone and soil backfill and not on the structure. For other installation considerations, such as migration of fines, ground water, and soft foundations, refer to ASTM D2321 guidelines.

ADVANCED DRAINAGE SYSTEMS, INC. ("ADS") HAS PREPARED THIS DETAIL BASED ON INFORMATION PROVIDED TO ADS. THIS DRAWING IS INTENDED TO DEPICT THE COMPONENTS AS REQUESTED. ADS HAS NOT PERFORMED ANY ENGINEERING OR DESIGN SERVICES FOR THIS PROJECT, NOR HAS ADS INDEPENDENTLY VERIFIED THE INFORMATION SUPPLIED. THE INSTALLATION DETAILS PROVIDED HEREIN ARE GENERAL RECOMMENDATIONS AND ARE NOT SPECIFIC FOR THIS PROJECT. THE DESIGN ENGINEER SHALL REVIEW THESE DETAILS PRIOR TO CONSTRUCTION. IT IS THE DESIGN ENGINEERS RESPONSIBILITY TO ENSURE THE DETAILS PROVIDED HEREIN MEETS OR EXCEEDS THE APPLICABLE NATIONAL, STATE, OR LOCAL REQUIREMENTS AND TO ENSURE THAT THE DETAILS PROVIDED HEREIN ARE ACCEPTABLE FOR THIS PROJECT.

STANDARD DETAIL  
48" POLYPROPYLENE BASIN  
SPECIFICATION

DRAWING NUMBER 7009-110-025 A



4640 TRUEMAN BLVD  
HILLIARD, OH 43026

DRAWN BY: NMH  
DATE: 01/30/23  
OK'S BY:  
SCALE: NTS  
SHEET: 1 OF 1

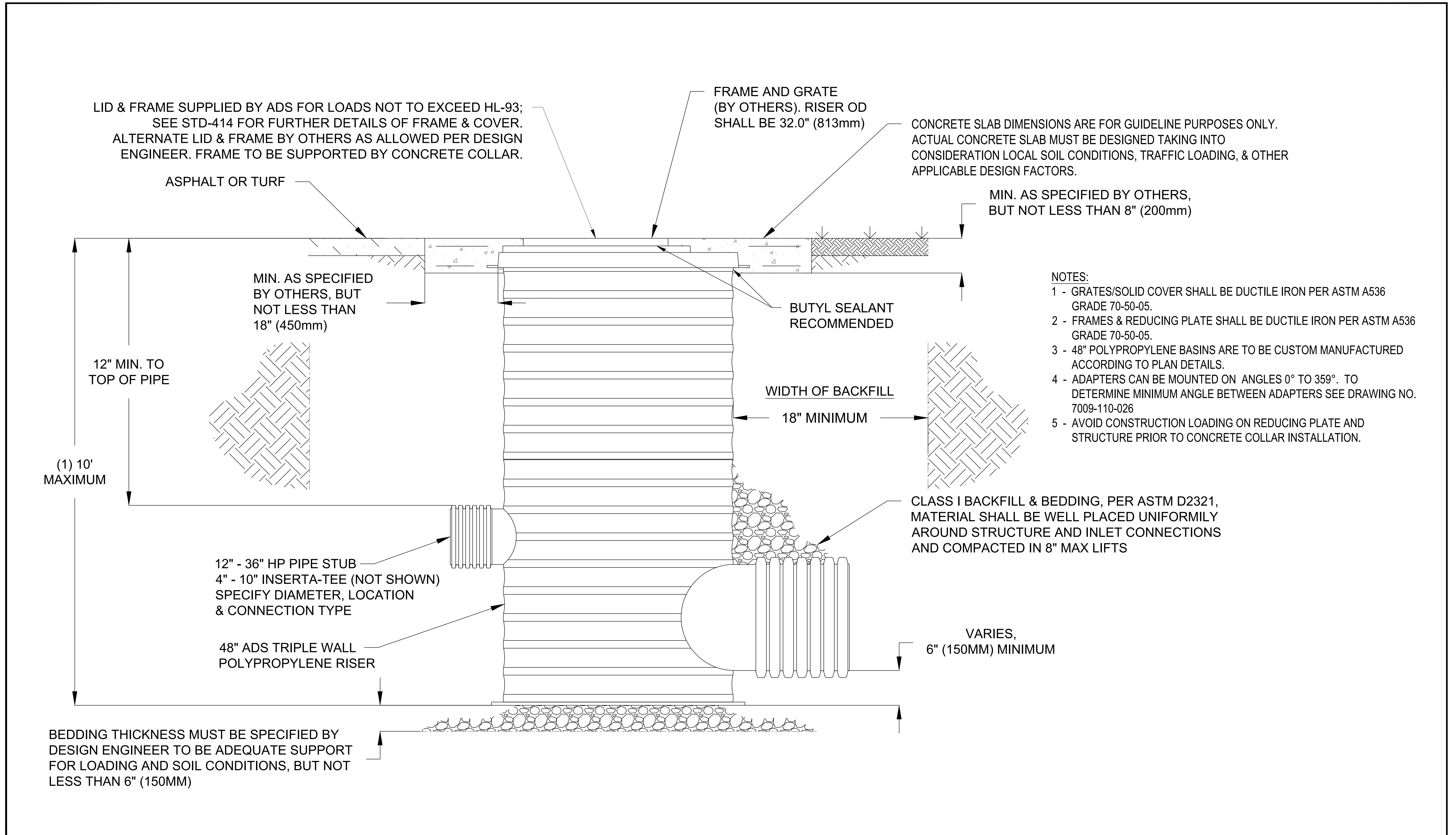

ADVANCED DRAINAGE SYSTEMS, INC. ("ADS") HAS PREPARED THIS DETAIL BASED ON INFORMATION PROVIDED TO ADS. THIS DRAWING IS INTENDED TO DEPICT THE COMPONENTS AS REQUESTED. ADS HAS NOT PERFORMED ANY ENGINEERING OR DESIGN SERVICES FOR THIS PROJECT, NOR HAS ADS INDEPENDENTLY VERIFIED THE INFORMATION SUPPLIED. THE INSTALLATION DETAILS PROVIDED HEREIN ARE GENERAL RECOMMENDATIONS AND ARE NOT SPECIFIC FOR THIS PROJECT. THE DESIGN ENGINEER SHALL REVIEW THESE DETAILS PRIOR TO CONSTRUCTION. IT IS THE DESIGN ENGINEER'S RESPONSIBILITY TO ENSURE THE DETAILS PROVIDED HEREIN MEETS OR EXCEEDS THE APPLICABLE NATIONAL, STATE, OR LOCAL REQUIREMENTS AND TO ENSURE THAT THE DETAILS PROVIDED HEREIN ARE ACCEPTABLE FOR THIS PROJECT.

STANDARD DETAIL  
48" POLYPROPYLENE BASIN W/ FLAT  
FRAME TOP INSTALLATION (48")

DRAWING NUMBER STD-403



4640 TRUEMAN BLVD  
HILLIARD, OH 43026

DRAWN BY:	NMH
DATE:	01/30/23
OK'S BY:	
SCALE:	NTS
SHEET:	1 OF 1



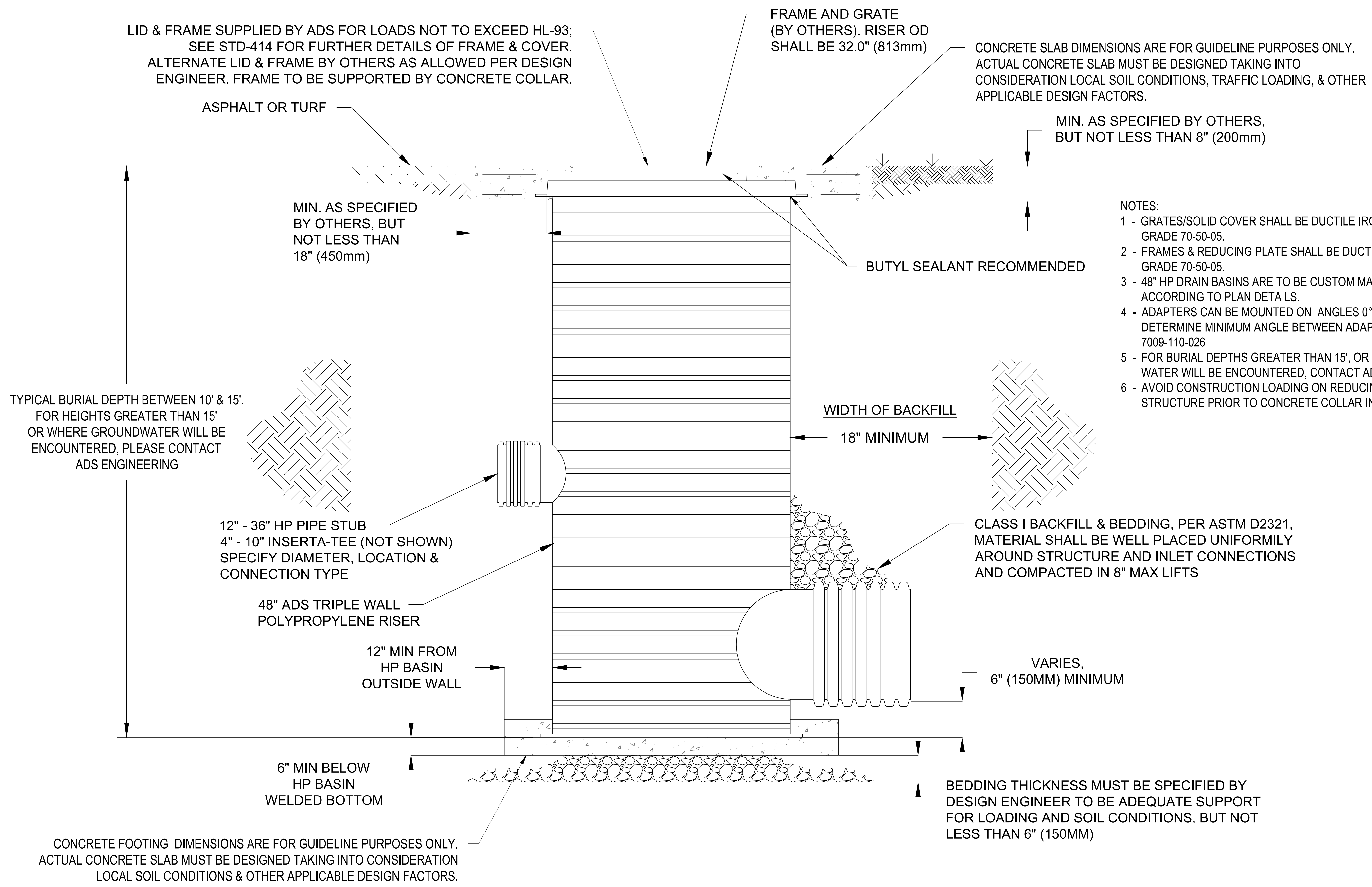

- NOTES:
- 1 - GRATES/SOLID COVER SHALL BE DUCTILE IRON PER ASTM A536 GRADE 70-50-05.
  - 2 - FRAMES & REDUCING PLATE SHALL BE DUCTILE IRON PER ASTM A536 GRADE 70-50-05.
  - 3 - 48" HP DRAIN BASINS ARE TO BE CUSTOM MANUFACTURED ACCORDING TO PLAN DETAILS.
  - 4 - ADAPTERS CAN BE MOUNTED ON ANGLES 0° TO 359°. TO DETERMINE MINIMUM ANGLE BETWEEN ADAPTERS SEE DRAWING NO. 7009-110-026
  - 5 - FOR BURIAL DEPTHS GREATER THAN 15', OR WHERE GROUND WATER WILL BE ENCOUNTERED, CONTACT ADS ENGINEERING.
  - 6 - AVOID CONSTRUCTION LOADING ON REDUCING PLATE AND STRUCTURE PRIOR TO CONCRETE COLLAR INSTALLATION.

ADVANCED DRAINAGE SYSTEMS, INC. ("ADS") HAS PREPARED THIS DETAIL BASED ON INFORMATION PROVIDED TO ADS. THIS DRAWING IS INTENDED TO DEPICT THE COMPONENTS AS REQUESTED. ADS HAS NOT PERFORMED ANY ENGINEERING OR DESIGN SERVICES FOR THIS PROJECT, NOR HAS ADS INDEPENDENTLY VERIFIED THE INFORMATION SUPPLIED. THE INSTALLATION DETAILS PROVIDED HEREIN ARE GENERAL RECOMMENDATIONS AND ARE NOT SPECIFIC FOR THIS PROJECT. THE DESIGN ENGINEER SHALL REVIEW THESE DETAILS PRIOR TO CONSTRUCTION. IT IS THE DESIGN ENGINEERS RESPONSIBILITY TO ENSURE THE DETAILS PROVIDED HEREIN MEETS OR EXCEEDS THE APPLICABLE NATIONAL, STATE, OR LOCAL REQUIREMENTS AND TO ENSURE THAT THE DETAILS PROVIDED HEREIN ARE ACCEPTABLE FOR THIS PROJECT.

STANDARD DETAIL  
 48" POLYPROPYLENE BASIN  
 10' - 15' DEEP INSTALLATION (48")  
 DRAWING NUMBER STD-403A

	4640 TRUEMAN BLVD HILLIARD, OH 43026
	DRAWN BY: NMH
	DATE: 01/24/23
	OK'S BY:
	SCALE: NTS
SHEET: 1 OF 1	

# OPTIONS FOR FRAME AND COVER

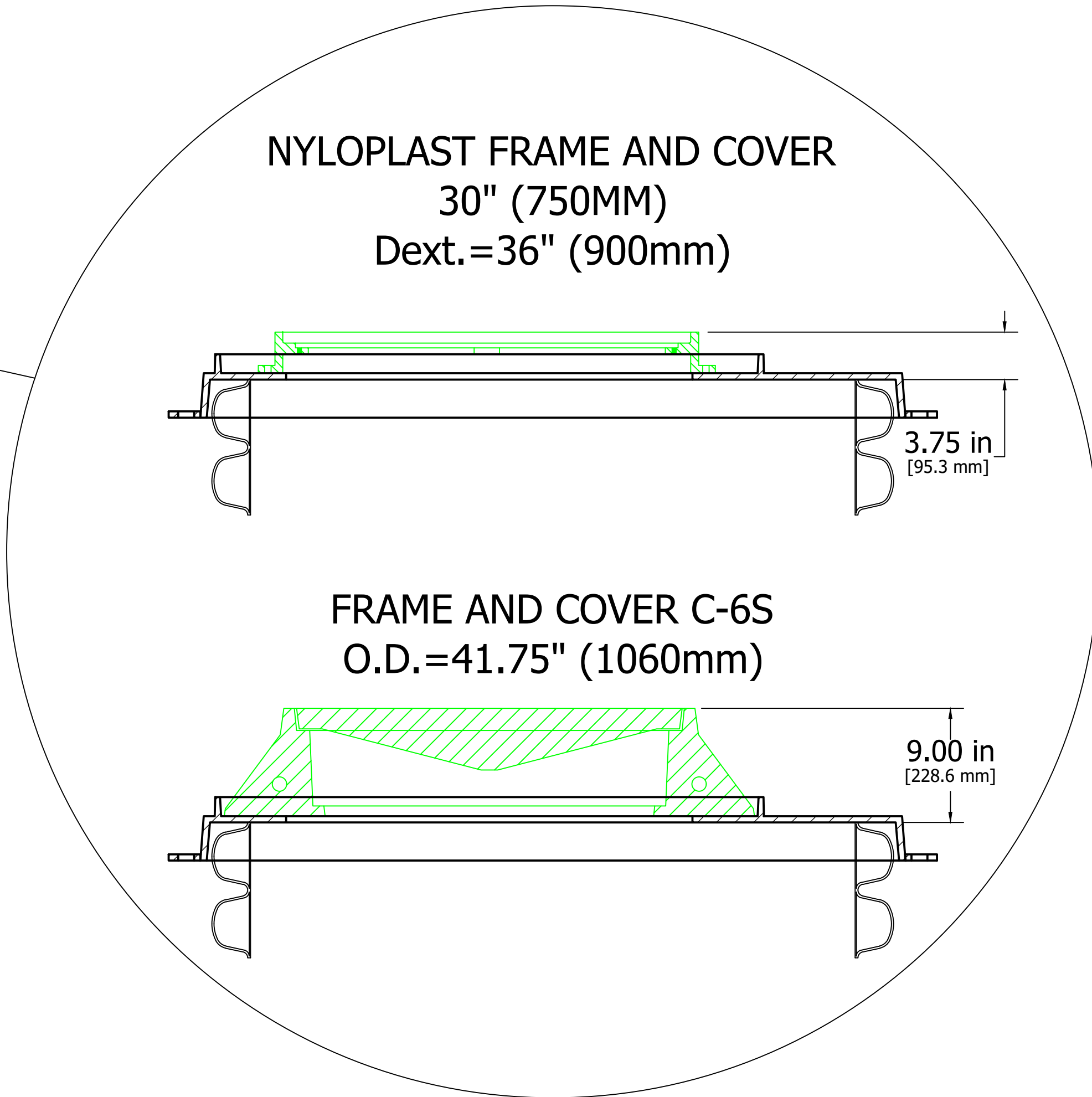
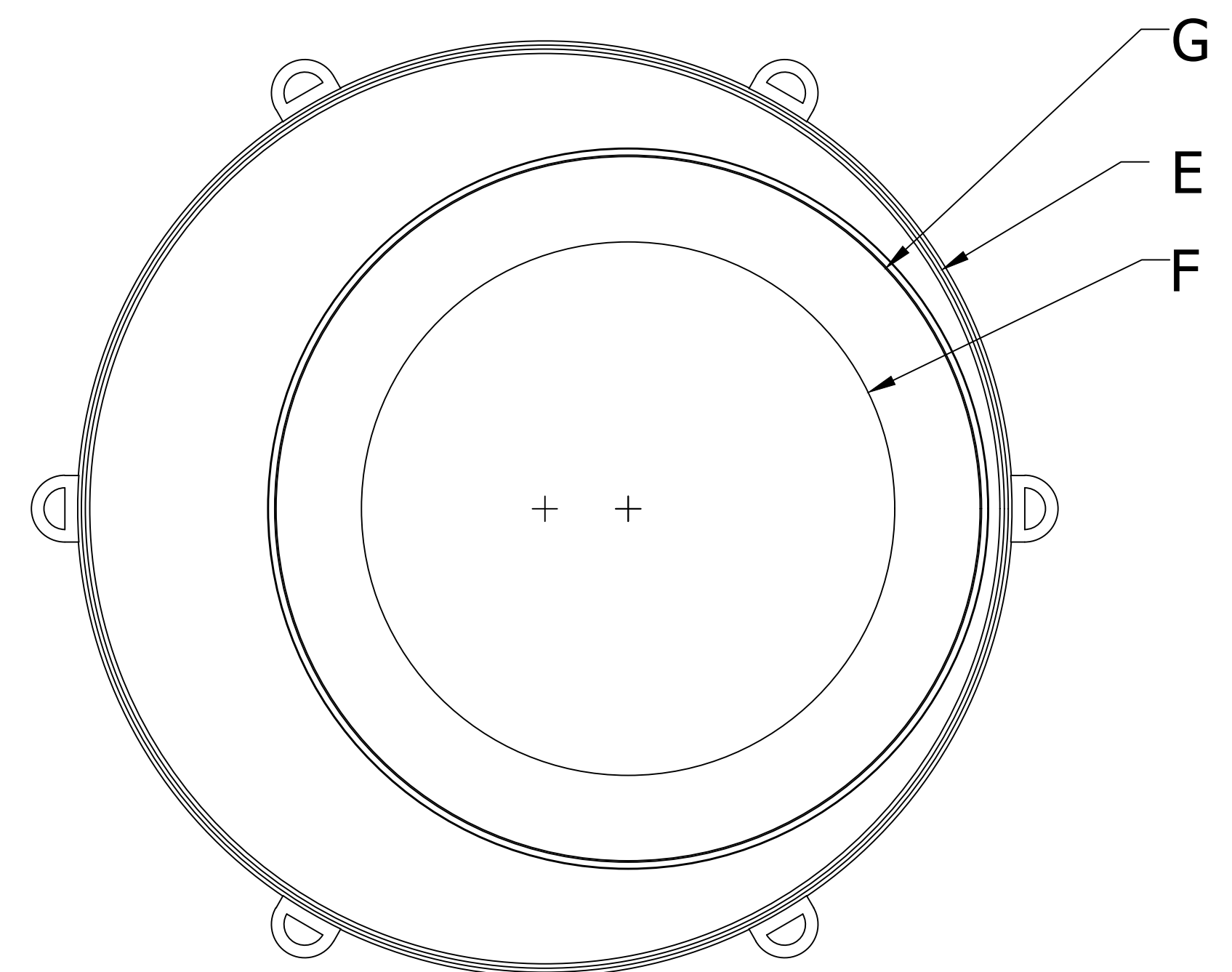
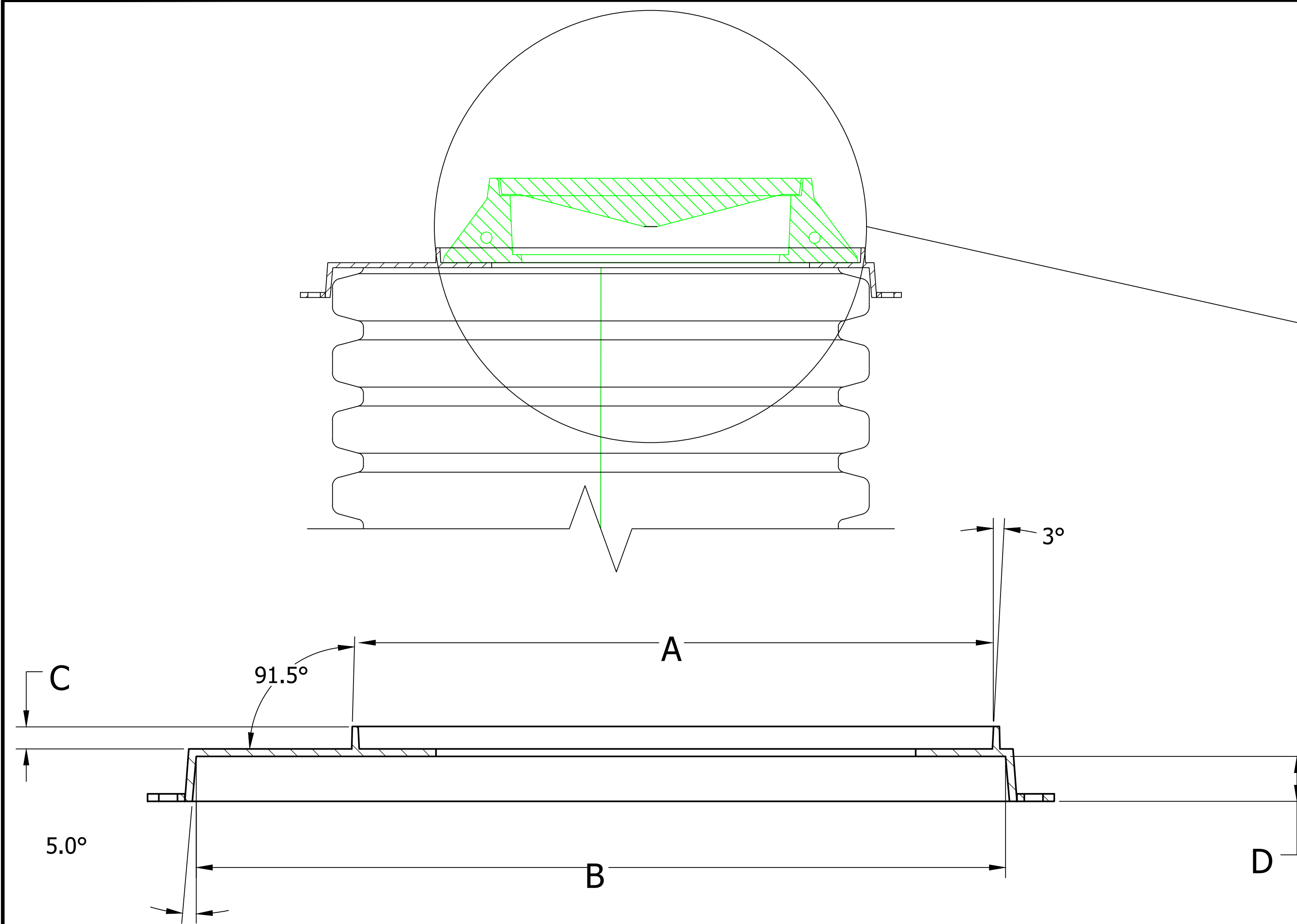

DIMENSIONS	
A	42.25" (1073.2 mm)
B	54.40" (1386.8 mm)
C	1.50" (38.1 mm)
D	3.00" (76.2 mm)
E	R27.80" (R706.1 mm)
F	Ø32.00" (Ø812.8 mm)
G	Ø42.25" (Ø1073 mm)

NOTE 1: THE REDUCING FRAME IS MADE OF DUCTILE IRON  
 NOTE 2: THE WEIGHT OF THE FRAME IS 308 POUNDS (139.7KG)

ADVANCED DRAINAGE SYSTEMS, INC. ("ADS") HAS PREPARED THIS DETAIL BASED ON INFORMATION PROVIDED TO ADS. THIS DRAWING IS INTENDED TO DEPICT THE COMPONENTS AS REQUESTED. ADS HAS NOT PERFORMED ANY ENGINEERING OR DESIGN SERVICES FOR THIS PROJECT, NOR HAS ADS INDEPENDENTLY VERIFIED THE INFORMATION SUPPLIED. THE INSTALLATION DETAILS PROVIDED HEREIN ARE GENERAL RECOMMENDATIONS AND ARE NOT SPECIFIC FOR THIS PROJECT. THE DESIGN ENGINEER SHALL REVIEW THESE DETAILS PRIOR TO CONSTRUCTION. IT IS THE DESIGN ENGINEERS RESPONSIBILITY TO ENSURE THE DETAILS PROVIDED HEREIN MEETS OR EXCEEDS THE APPLICABLE NATIONAL, STATE, OR LOCAL REQUIREMENTS AND TO ENSURE THAT THE DETAILS PROVIDED HEREIN ARE ACCEPTABLE FOR THIS PROJECT.

STANDARD DETAIL  
 FRAME & COVER FOR 48"  
 POLYPROPYLENE BASIN  
 DRAWING NUMBER STD-414



4640 TRUEMAN BLVD  
 HILLIARD, OH 43026

DRAWN BY: NMH  
 DATE: 9/23/22  
 OK'S BY: CKM  
 SCALE: NTS  
 SHEET: 1 OF 1



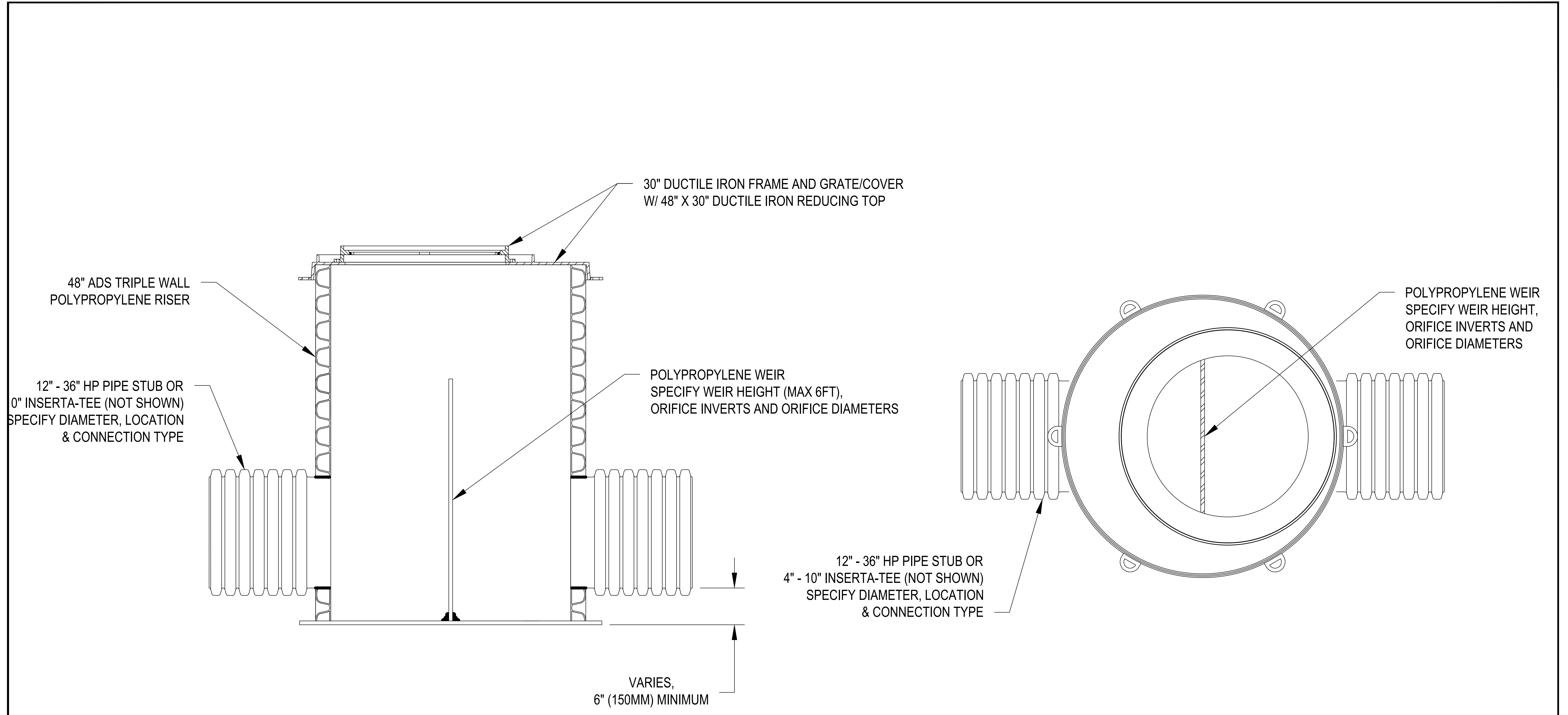

**NOTES:**

- 1 - FOR BURIAL DEPTHS GREATER THAN 10' BUT NO MORE THAN 15', REFERENCE DRAWING STD-403A
- 2 - AVOID CONSTRUCTION LOADING ON DOME AND STRUCTURE PRIOR TO CONCRETE COLLAR INSTALLATION
- 3 - WEIR LOCATION, ORIENTATION AND FABRICATION TO BE DETERMINED BASED ON STUB LOCATION
- 4 - MAX 6FT WEIR HEIGHT. WEIR MAY REQUIRE ADDED SUPPORT WHEN EXCEEDING 2FT.
- 5 - 48" POLYPROPYLENE BASINS WITH WEIRS REQUIRE REVIEW BY ADS ENGINEERING

ADVANCED DRAINAGE SYSTEMS, INC. ("ADS") HAS PREPARED THIS DETAIL BASED ON INFORMATION PROVIDED TO ADS. THIS DRAWING IS INTENDED TO DEPICT THE COMPONENTS AS REQUESTED. ADS HAS NOT PERFORMED ANY ENGINEERING OR DESIGN SERVICES FOR THIS PROJECT, NOR HAS ADS INDEPENDENTLY VERIFIED THE INFORMATION SUPPLIED. THE INSTALLATION DETAILS PROVIDED HEREIN ARE GENERAL RECOMMENDATIONS AND ARE NOT SPECIFIC FOR THIS PROJECT. THE DESIGN ENGINEER SHALL REVIEW THESE DETAILS PRIOR TO CONSTRUCTION. IT IS THE DESIGN ENGINEERS RESPONSIBILITY TO ENSURE THE DETAILS PROVIDED HEREIN MEETS OR EXCEEDS THE APPLICABLE NATIONAL, STATE, OR LOCAL REQUIREMENTS AND TO ENSURE THAT THE DETAILS PROVIDED HEREIN ARE ACCEPTABLE FOR THIS PROJECT.

STANDARD DETAIL  
48" POLYPROPYLENE BASIN  
WITH WEIR PLATE



4640 TRUEMAN BLVD  
HILLIARD, OH 43026

DRAWING NUMBER 7009-110-019 A

DRAWN BY:	NMH
DATE:	02/02/23
OK'S BY:	
SCALE:	NTS
SHEET:	1 OF 1

# MARMAC WRAP

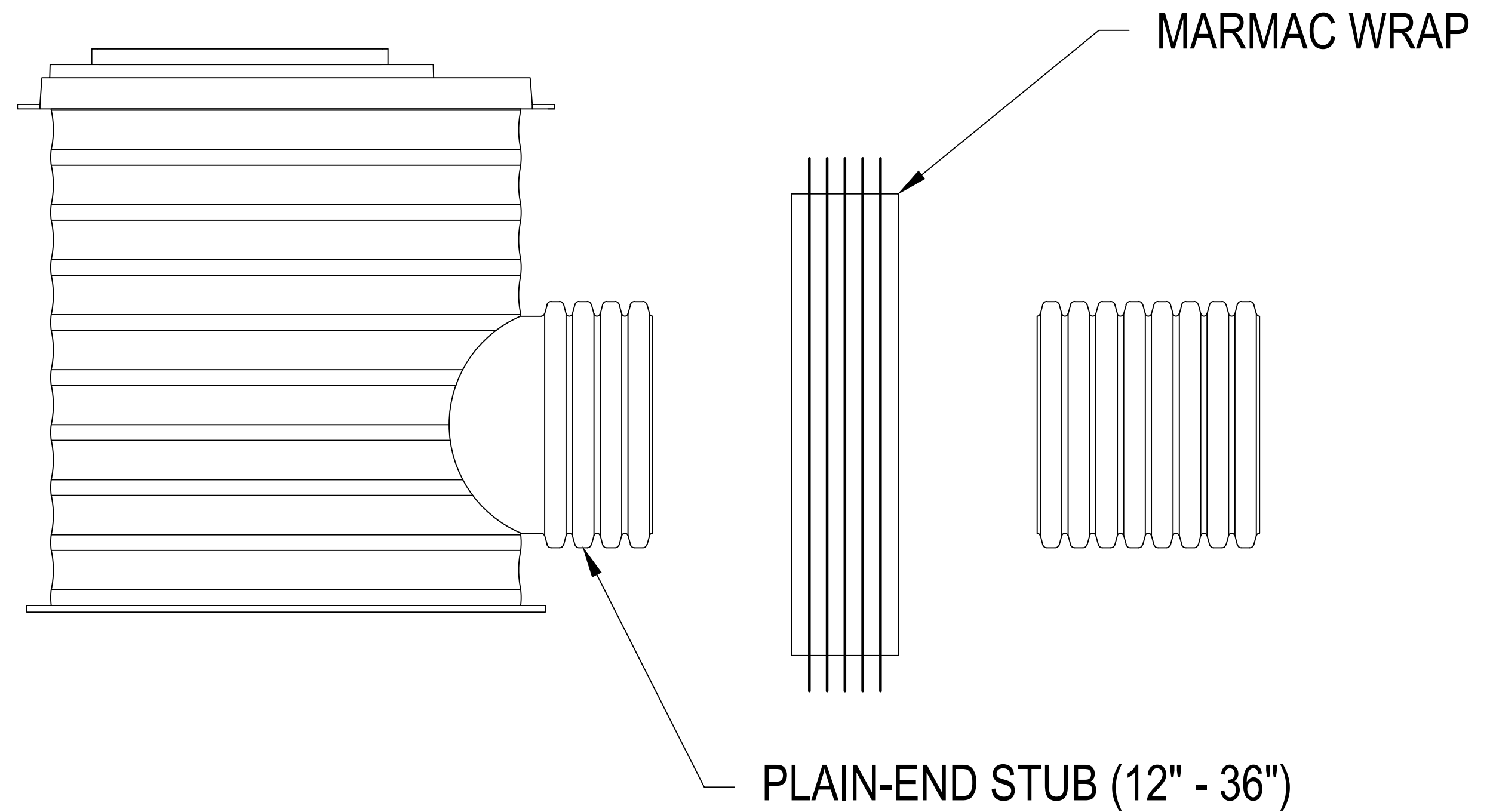

# INSERTA-TEE

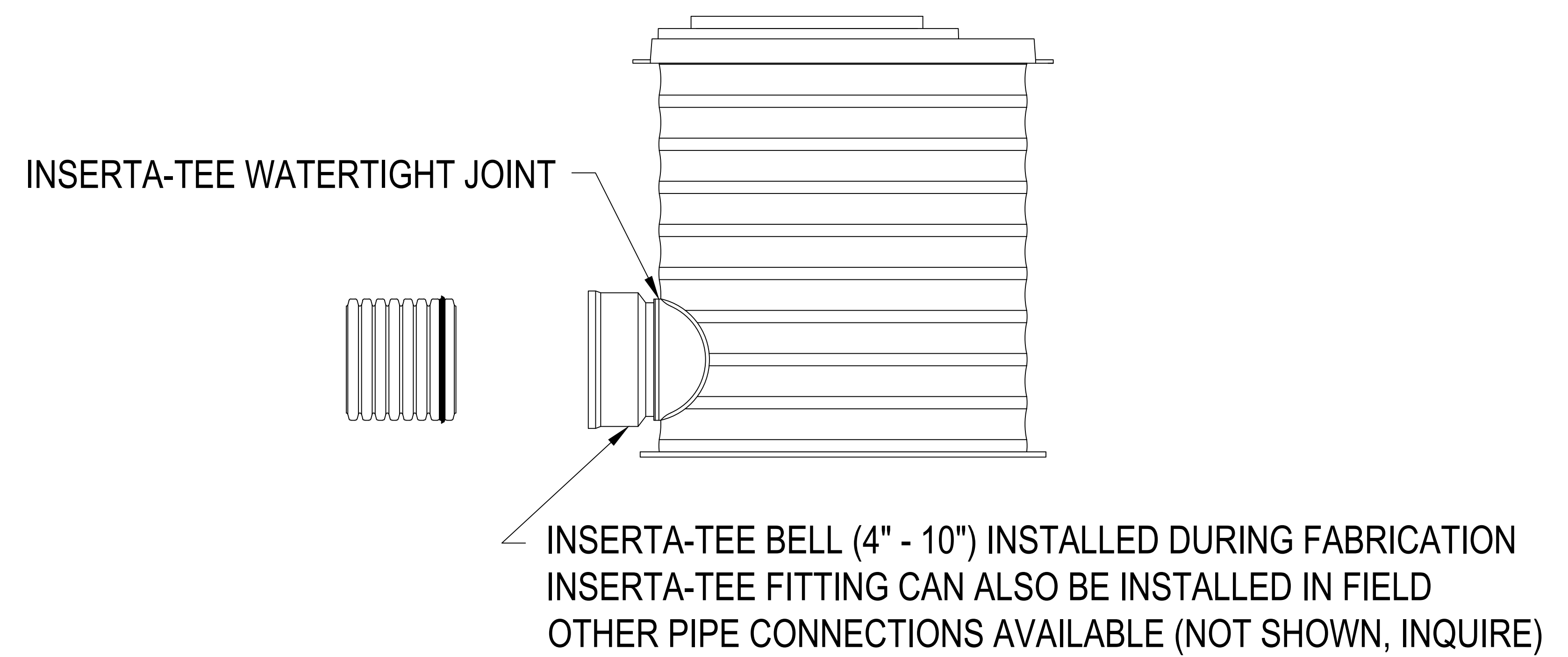

1. REFER TO DETAIL STD-403 FOR MINIMUM DEPTH GUIDLINES AND DETAIL STD-403A FOR DEEPER BURIALS.

ADVANCED DRAINAGE SYSTEMS, INC. ("ADS") HAS PREPARED THIS DETAIL BASED ON INFORMATION PROVIDED TO ADS. THIS DRAWING IS INTENDED TO DEPICT THE COMPONENTS AS REQUESTED. ADS HAS NOT PERFORMED ANY ENGINEERING OR DESIGN SERVICES FOR THIS PROJECT, NOR HAS ADS INDEPENDENTLY VERIFIED THE INFORMATION SUPPLIED. THE INSTALLATION DETAILS PROVIDED HEREIN ARE GENERAL RECOMMENDATIONS AND ARE NOT SPECIFIC FOR THIS PROJECT. THE DESIGN ENGINEER SHALL REVIEW THESE DETAILS PRIOR TO CONSTRUCTION. IT IS THE DESIGN ENGINEERS RESPONSIBILITY TO ENSURE THE DETAILS PROVIDED HEREIN MEETS OR EXCEEDS THE APPLICABLE NATIONAL, STATE, OR LOCAL REQUIREMENTS AND TO ENSURE THAT THE DETAILS PROVIDED HEREIN ARE ACCEPTABLE FOR THIS PROJECT.

STANDARD DETAIL  
 48 IN POLYPROPYLENE BASIN  
 CONNECTION OPTIONS

DRAWING NUMBER 7009-110-013 A



4640 TRUEMAN BLVD  
 HILLIARD, OH 43026

DRAWN BY: NMH  
 DATE: 01/30/23  
 OK'S BY:  
 SCALE: NTS  
 SHEET: 1 OF 1



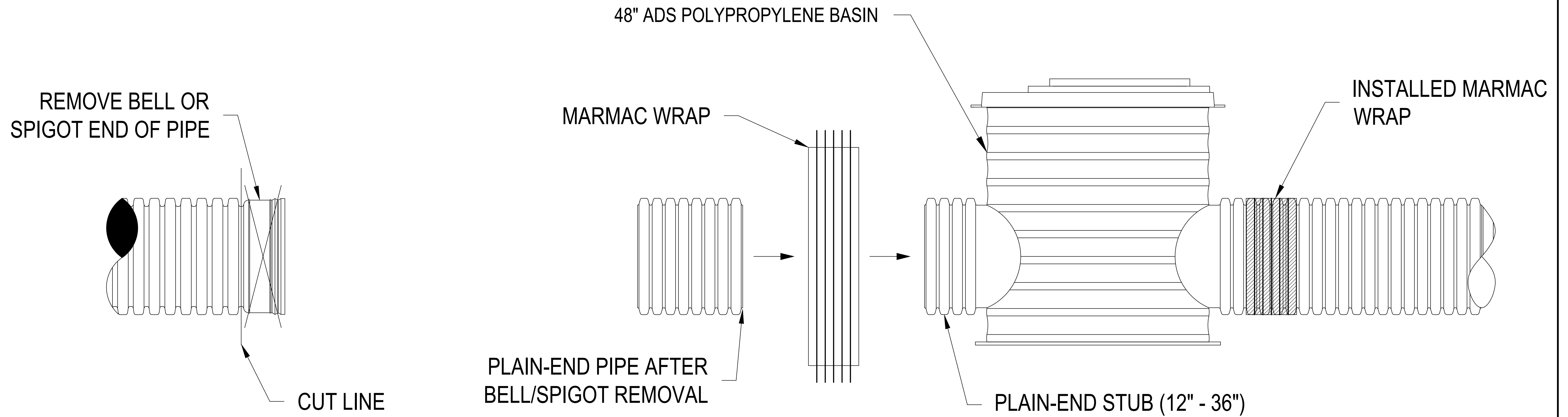

ADVANCED DRAINAGE SYSTEMS, INC. ("ADS") HAS PREPARED THIS DETAIL BASED ON INFORMATION PROVIDED TO ADS. THIS DRAWING IS INTENDED TO DEPICT THE COMPONENTS AS REQUESTED. ADS HAS NOT PERFORMED ANY ENGINEERING OR DESIGN SERVICES FOR THIS PROJECT, NOR HAS ADS INDEPENDENTLY VERIFIED THE INFORMATION SUPPLIED. THE INSTALLATION DETAILS PROVIDED HEREIN ARE GENERAL RECOMMENDATIONS AND ARE NOT SPECIFIC FOR THIS PROJECT. THE DESIGN ENGINEER SHALL REVIEW THESE DETAILS PRIOR TO CONSTRUCTION. IT IS THE DESIGN ENGINEERS RESPONSIBILITY TO ENSURE THE DETAILS PROVIDED HEREIN MEETS OR EXCEEDS THE APPLICABLE NATIONAL, STATE, OR LOCAL REQUIREMENTS AND TO ENSURE THAT THE DETAILS PROVIDED HEREIN ARE ACCEPTABLE FOR THIS PROJECT.

STANDARD DETAIL  
 48 IN POLYPROPYLENE BASIN  
 W/ MARMAC WRAP CONNECTION  
 DRAWING NUMBER STD - 210

**ADS**  
 4640 TRUEMAN BLVD  
 HILLIARD, OH 43026

DRAWN BY: NMH  
 DATE: 03/01/23  
 OK'S BY:  
 SCALE: NTS  
 SHEET: 1 OF 1

NOTES:

1. CONNECTION AND PIPE TO BE BACKFILLED PER ASTM D2321, LATEST EDITION.

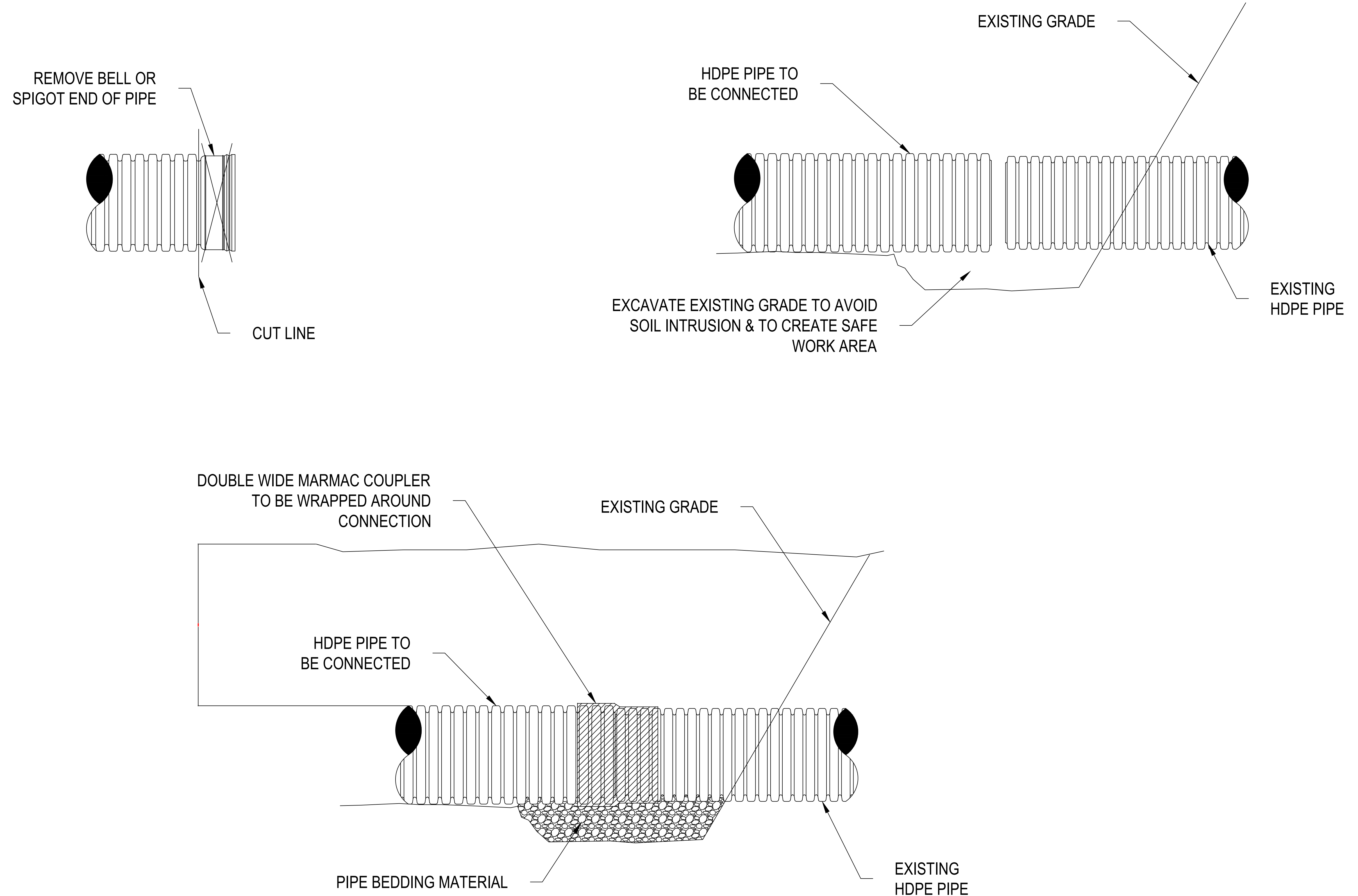

ADVANCED DRAINAGE SYSTEMS, INC. ("ADS") HAS PREPARED THIS DETAIL BASED ON INFORMATION PROVIDED TO ADS. THIS DRAWING IS INTENDED TO DEPICT THE COMPONENTS AS REQUESTED. ADS HAS NOT PERFORMED ANY ENGINEERING OR DESIGN SERVICES FOR THIS PROJECT, NOR HAS ADS INDEPENDENTLY VERIFIED THE INFORMATION SUPPLIED. THE INSTALLATION DETAILS PROVIDED HEREIN ARE GENERAL RECOMMENDATIONS AND ARE NOT SPECIFIC FOR THIS PROJECT. THE DESIGN ENGINEER SHALL REVIEW THESE DETAILS PRIOR TO CONSTRUCTION. IT IS THE DESIGN ENGINEERS RESPONSIBILITY TO ENSURE THE DETAILS PROVIDED HEREIN MEETS OR EXCEEDS THE APPLICABLE NATIONAL, STATE, OR LOCAL REQUIREMENTS AND TO ENSURE THAT THE DETAILS PROVIDED HEREIN ARE ACCEPTABLE FOR THIS PROJECT.

STANDARD DETAIL  
HDPE TO HDPE  
CONNECTION (MARMAC)

DRAWING NUMBER STD - 608



4640 TRUEMAN BLVD  
HILLIARD, OH 43026

DRAWN BY:	NMH
DATE:	03/01/23
OK'S BY:	
SCALE:	NTS
SHEET:	1 OF 1



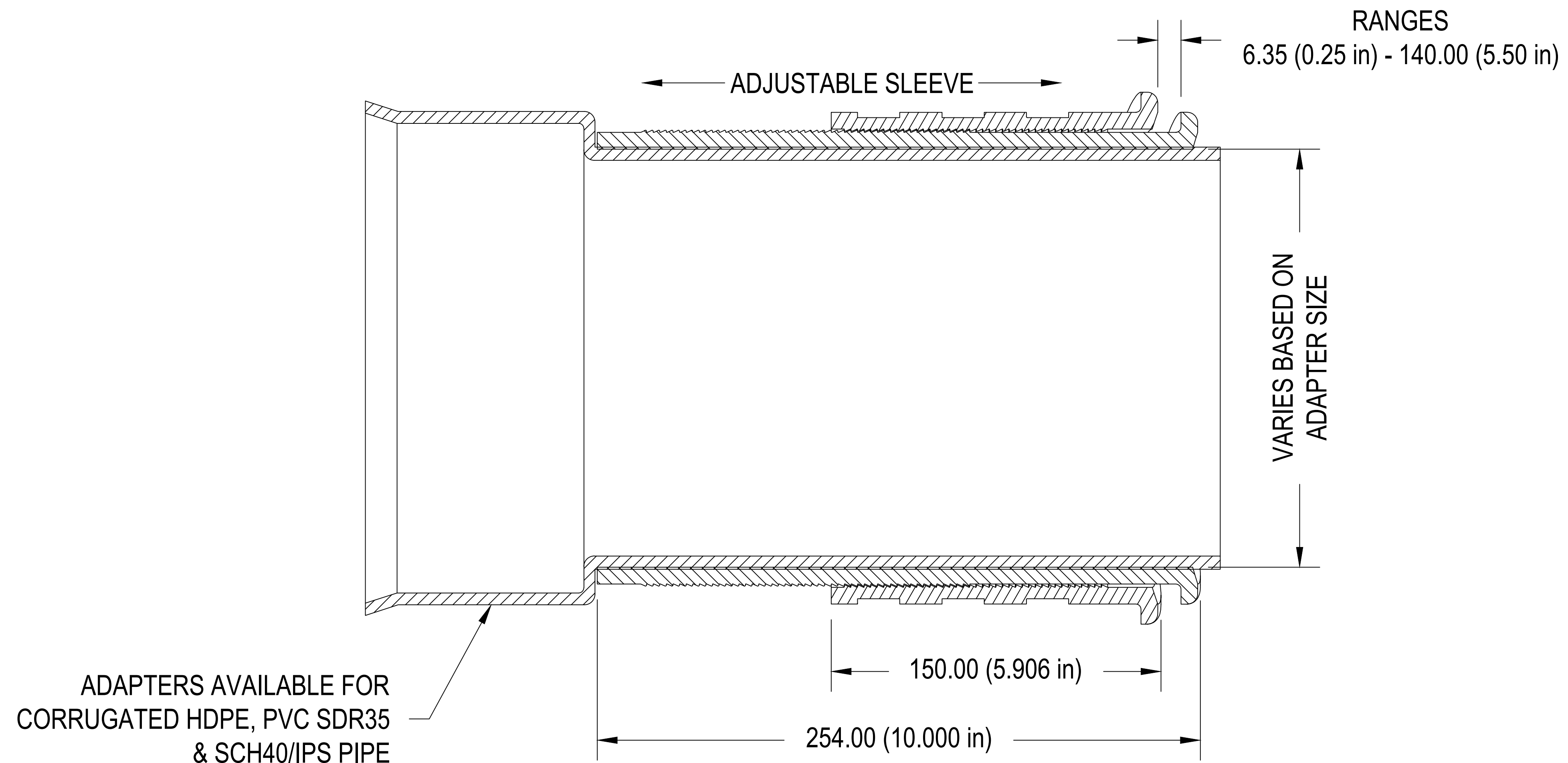
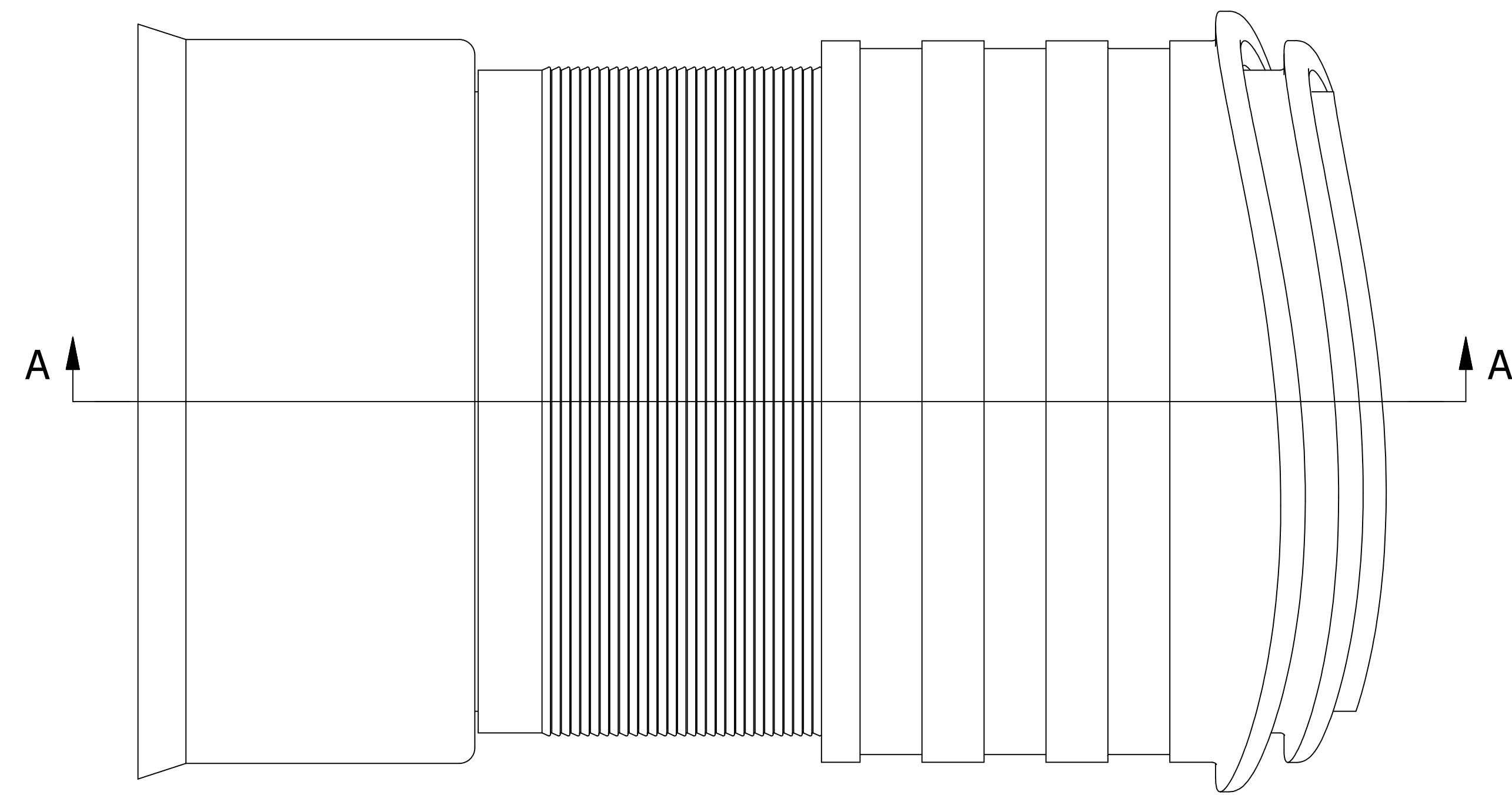

SECTION A-A

ADVANCED DRAINAGE SYSTEMS, INC. ("ADS") HAS PREPARED THIS DETAIL BASED ON INFORMATION PROVIDED TO ADS. THIS DRAWING IS INTENDED TO DEPICT THE COMPONENTS AS REQUESTED. ADS HAS NOT PERFORMED ANY ENGINEERING OR DESIGN SERVICES FOR THIS PROJECT, NOR HAS ADS INDEPENDENTLY VERIFIED THE INFORMATION SUPPLIED. THE INSTALLATION DETAILS PROVIDED HEREIN ARE GENERAL RECOMMENDATIONS AND ARE NOT SPECIFIC FOR THIS PROJECT. THE DESIGN ENGINEER SHALL REVIEW THESE DETAILS PRIOR TO CONSTRUCTION. IT IS THE DESIGN ENGINEERS RESPONSIBILITY TO ENSURE THE DETAILS PROVIDED HEREIN MEETS OR EXCEEDS THE APPLICABLE NATIONAL, STATE, OR LOCAL REQUIREMENTS AND TO ENSURE THAT THE DETAILS PROVIDED HEREIN ARE ACCEPTABLE FOR THIS PROJECT.

STANDARD DETAIL  
 INSERTA-TEE  
 ONEFIT DETAIL

DRAWING NUMBER IAT ONEFIT



4640 TRUEMAN BLVD  
 HILLIARD, OH 43026

DRAWN BY:	NMH
DATE:	03/01/23
OK'S BY:	
SCALE:	NTS
SHEET:	1 OF 1

ADAPTER SIZE	48" HP MH
12" - 12"	51°
<b>12" - 15"</b>	<b>54°</b>
12" - 18"	59°
<b>12" - 24"</b>	<b>69°</b>
12" - 30"	81°
<b>12" - 36"</b>	<b>93°</b>
15" - 15"	59°
<b>15" - 18"</b>	<b>63°</b>
15" - 24"	73°
<b>15" - 30"</b>	<b>85°</b>
15" - 36"	99°
<b>18" - 18"</b>	<b>68°</b>
18" - 24"	78°
<b>18" - 30"</b>	<b>90°</b>
18" - 36"	105°
<b>24" - 24"</b>	<b>87°</b>
24" - 30"	100°
<b>24" - 36"</b>	<b>112°</b>
30" - 30"	112°
<b>30" - 36"</b>	<b>124°</b>
36" - 36"	137°

1. MEASURE THE ANGLE BETWEEN THE PIPE RUNS DIRECTLY FROM THE STORM DRAIN PLANS FOR EACH STRUCTURE LOCATION . THE ANGLE BETWEEN EVERY PIPE RUN MUST BE MEASURED.
2. REFER TO DRAWING NO. 7001-110-012 FOR MINIMUM ANGLE REQUIREMENTS. THE ANGLES LISTED ARE THE MINIMUM ANGLES POSSIBLE BETWEEN ADAPTERS DUE TO PRODUCTION RESTRICTIONS.
3. WHEN RECORDING THE MEASURED ANGLES ON AN ORDER FORM BE SURE TO MEASURE THE ANGLES IN A CLOCKWISE DIRECTION & LABEL THE ANGLE POSITIONS STARTING WITH 0° AT THE TOP OF THE PAGE, THE 12 O'CLOCK POSITION; 90° WOULD THEN FOLLOW AT 3 O'CLOCK, 180° AT 6 O'CLOCK, & SO FORTH (TYPICALLY YOUR OUTLET PIPE WOULD BE LABELED AT 0°).

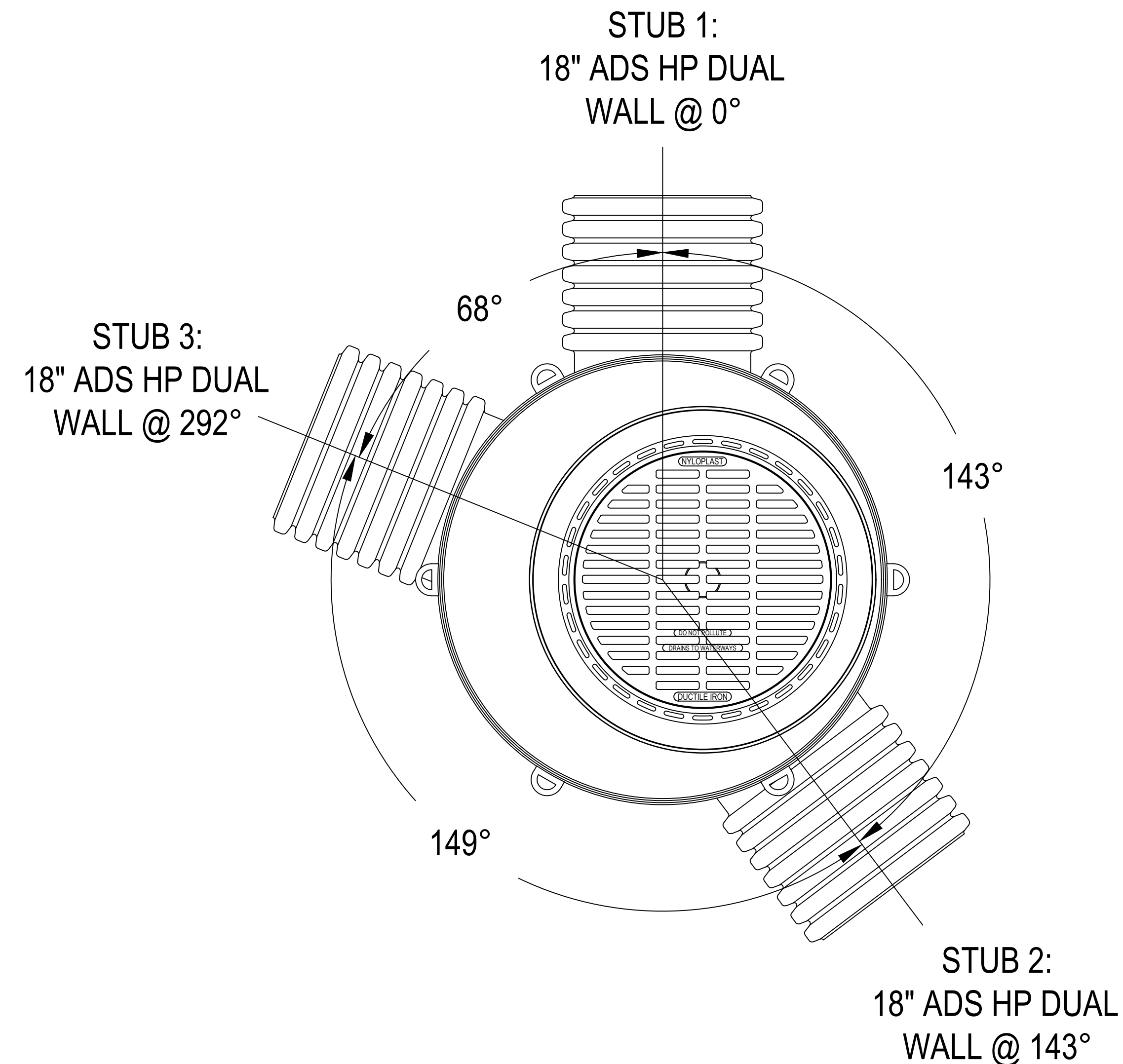

**POLYPROPYLENE BASIN TOP VIEW**  
WITH REDUCING PLATE, FRAME & GRATE

EXAMPLE:  
THE 48" POLYPROPYLENE BASIN ABOVE HAS THREE PIPE STUBS:  
18" ADS HP DUAL WALL ADAPTER @ 0°  
18" ADS HP DUAL WALL ADAPTER @ 143°  
18" ADS HP DUAL WALL ADAPTER @ 292°

ACCORDING TO THE MINIMUM ANGLE CHART A 48" POLYPROPYLENE BASIN REQUIRES A MINIMUM OF 68° BETWEEN AN 18" & 18" STUB. STUB 2 EXCEEDS THE MINIMUM ANGLES BETWEEN STUB 1 AND STUB 3 AND MEETS THE MINIMUM ANGLE REQUIREMENTS. STUB 3 IS 68° FROM STUB 1 AND THEREFORE IS AT THE MINIMUM ALLOWED ANGLE BETWEEN THE TWO ADAPTER SIZES.

ADVANCED DRAINAGE SYSTEMS, INC. ("ADS") HAS PREPARED THIS DETAIL BASED ON INFORMATION PROVIDED TO ADS. THIS DRAWING IS INTENDED TO DEPICT THE COMPONENTS AS REQUESTED. ADS HAS NOT PERFORMED ANY ENGINEERING OR DESIGN SERVICES FOR THIS PROJECT, NOR HAS ADS INDEPENDENTLY VERIFIED THE INFORMATION SUPPLIED. THE INSTALLATION DETAILS PROVIDED HEREIN ARE GENERAL RECOMMENDATIONS AND ARE NOT SPECIFIC FOR THIS PROJECT. THE DESIGN ENGINEER SHALL REVIEW THESE DETAILS PRIOR TO CONSTRUCTION. IT IS THE DESIGN ENGINEERS RESPONSIBILITY TO ENSURE THE DETAILS PROVIDED HEREIN MEETS OR EXCEEDS THE APPLICABLE NATIONAL, STATE, OR LOCAL REQUIREMENTS AND TO ENSURE THAT THE DETAILS PROVIDED HEREIN ARE ACCEPTABLE FOR THIS PROJECT.

STANDARD DETAIL  
48" POLYPROPYLENE BASIN  
MINIMUM ANGLE CHART

DRAWING NUMBER 7009-110-028 A



4640 TRUEMAN BLVD  
HILLIARD, OH 43026

DRAWN BY: NMH  
DATE: 01/30/23  
OK'S BY:  
SCALE: NTS  
SHEET: 1 OF 1



# 3099CGS

APPROX. DRAIN AREA = 324.00 SQ IN  
 APPROX. WEIGHT WITH FRAME = 237.00 LBS

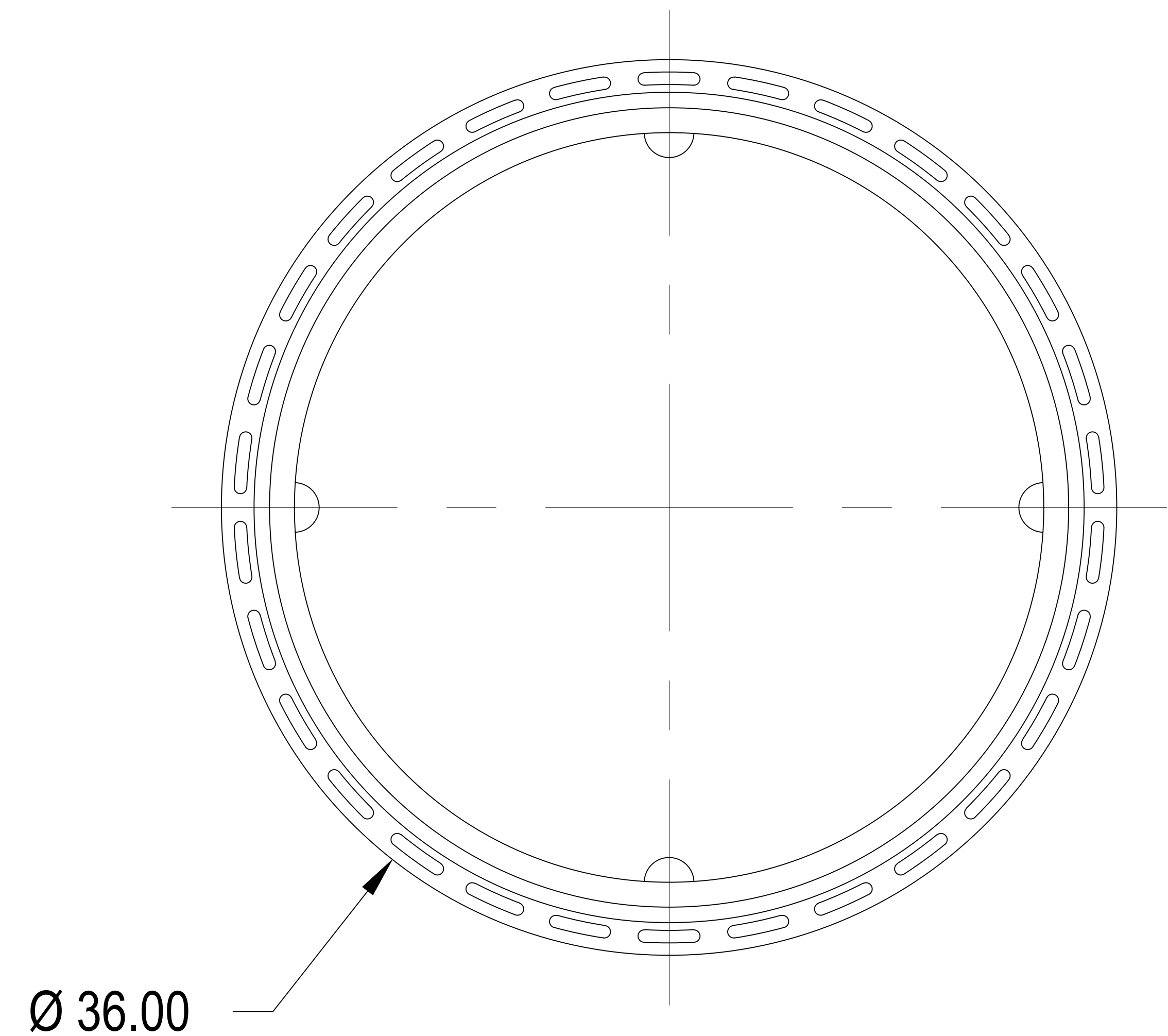
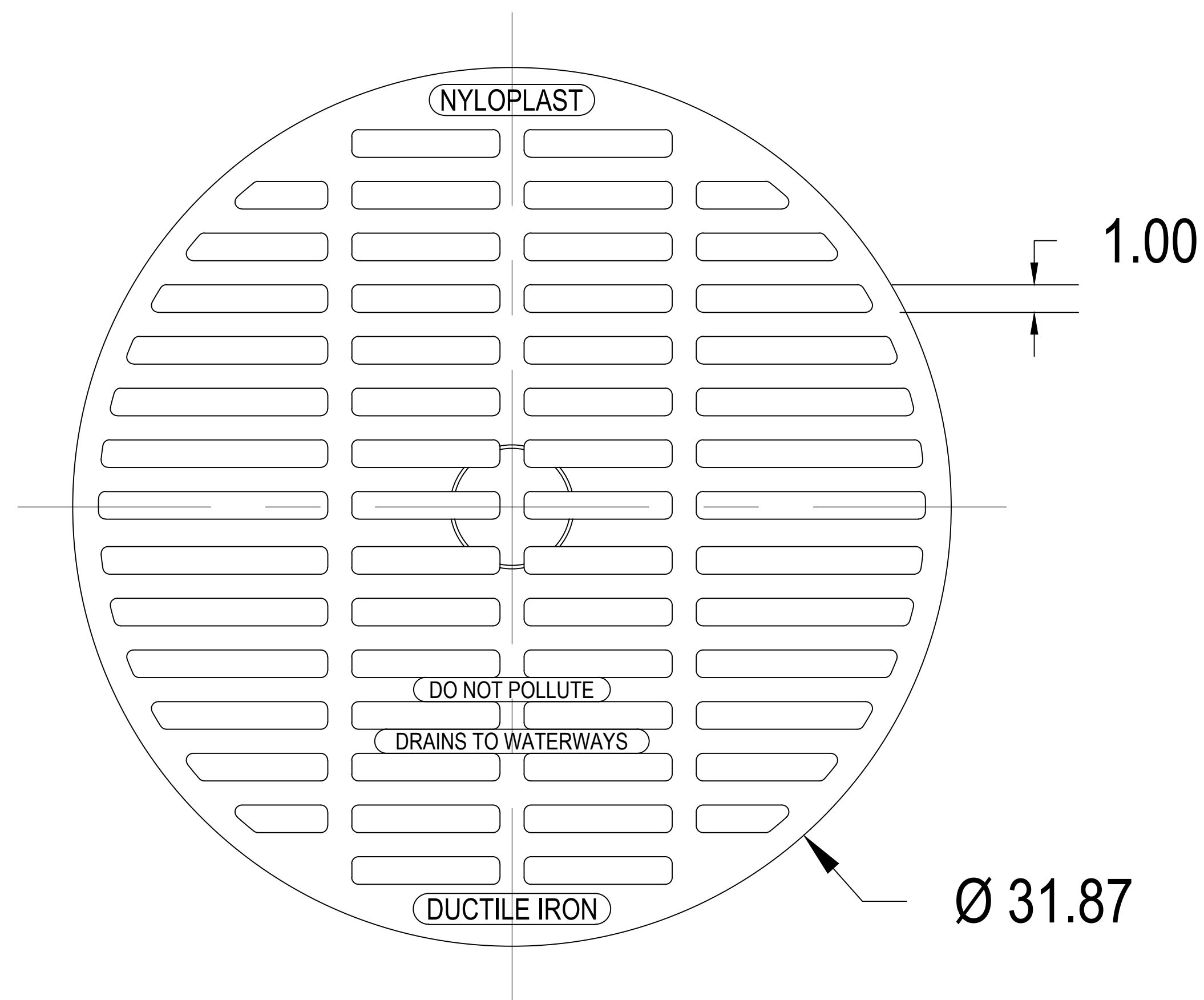
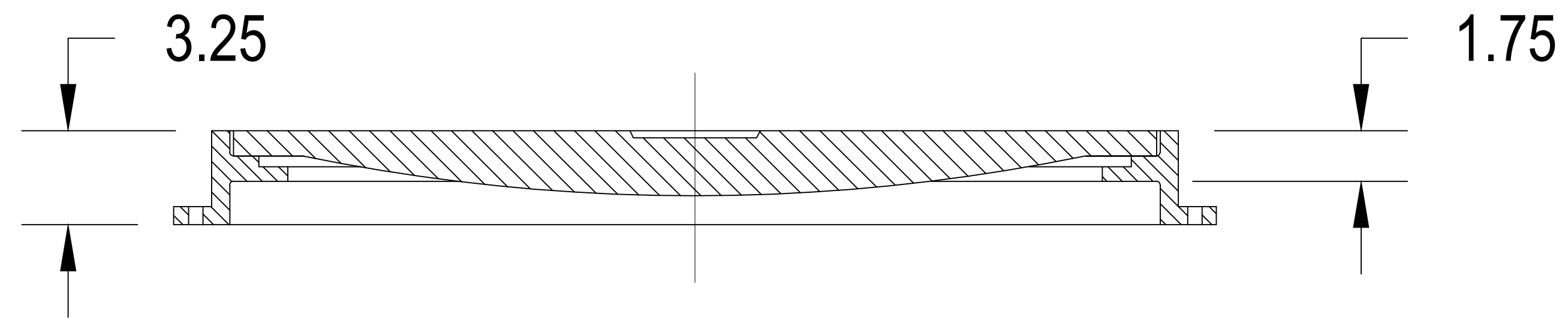

DIMENSIONS ARE FOR REFERENCE ONLY  
 ACTUAL DIMENSIONS MAY VARY  
 DIMENSIONS ARE IN INCHES  
 GRATE MEETS H-20 LOAD RATING  
 QUALITY: MATERIALS SHALL CONFORM TO ASTM A536 GRADE 70-50-05  
 PAINT: CASTINGS ARE FURNISHED WITH A BLACK PAINT  
 LOCKING DEVICE AVAILABLE UPON REQUEST SEE DRAWING NO.  
 7001-110-022

ADVANCED DRAINAGE SYSTEMS, INC. ("ADS") HAS PREPARED THIS DETAIL BASED ON INFORMATION PROVIDED TO ADS. THIS DRAWING IS INTENDED TO DEPICT THE COMPONENTS AS REQUESTED. ADS HAS NOT PERFORMED ANY ENGINEERING OR DESIGN SERVICES FOR THIS PROJECT, NOR HAS ADS INDEPENDENTLY VERIFIED THE INFORMATION SUPPLIED. THE INSTALLATION DETAILS PROVIDED HEREIN ARE GENERAL RECOMMENDATIONS AND ARE NOT SPECIFIC FOR THIS PROJECT. THE DESIGN ENGINEER SHALL REVIEW THESE DETAILS PRIOR TO CONSTRUCTION. IT IS THE DESIGN ENGINEERS RESPONSIBILITY TO ENSURE THE DETAILS PROVIDED HEREIN MEETS OR EXCEEDS THE APPLICABLE NATIONAL, STATE, OR LOCAL REQUIREMENTS AND TO ENSURE THAT THE DETAILS PROVIDED HEREIN ARE ACCEPTABLE FOR THIS PROJECT.

STANDARD DETAIL  
 NYLOPLAST 30 IN STANDARD  
 GRATE ASSEMBLY - TYPE B

DRAWING NUMBER 7001-110-221



4640 TRUEMAN BLVD  
 HILLIARD, OH 43026

DRAWN BY: NMH  
 DATE: 02/06/23  
 OK'S BY:  
 SCALE: NTS  
 SHEET: 1 OF 1

# 3099CGC

APPROX. WEIGHT WITH FRAME = 262.50 LBS

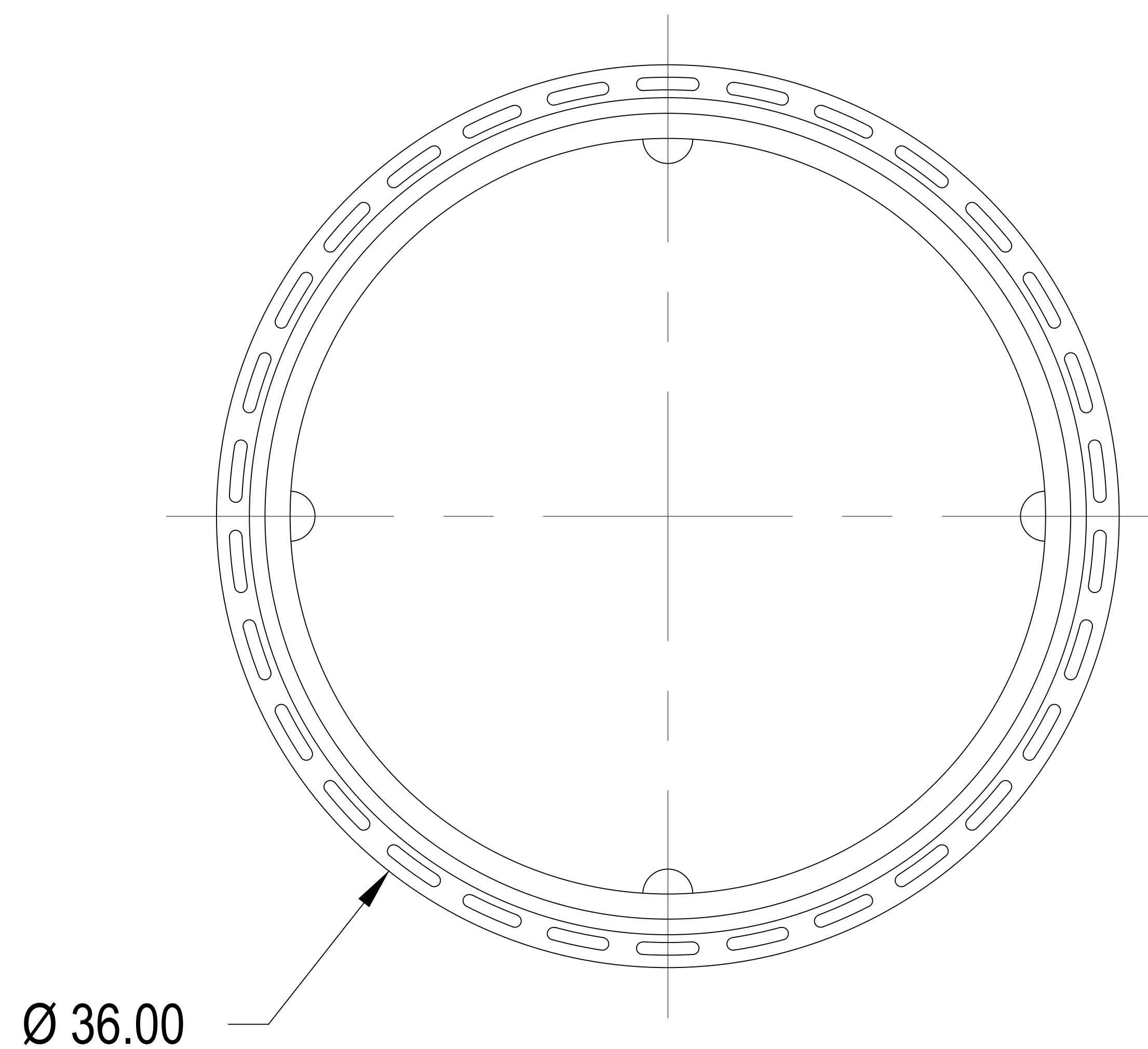
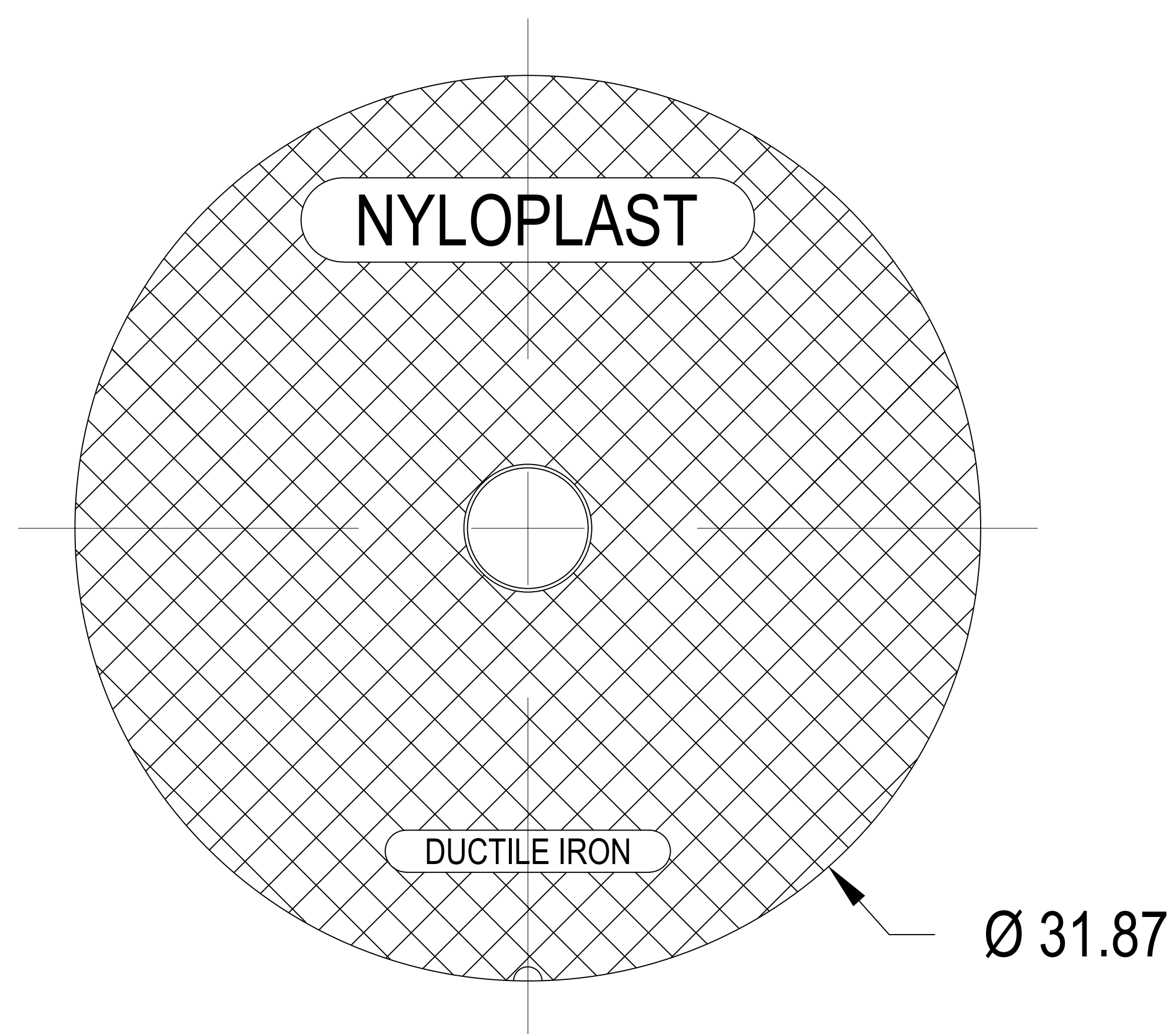
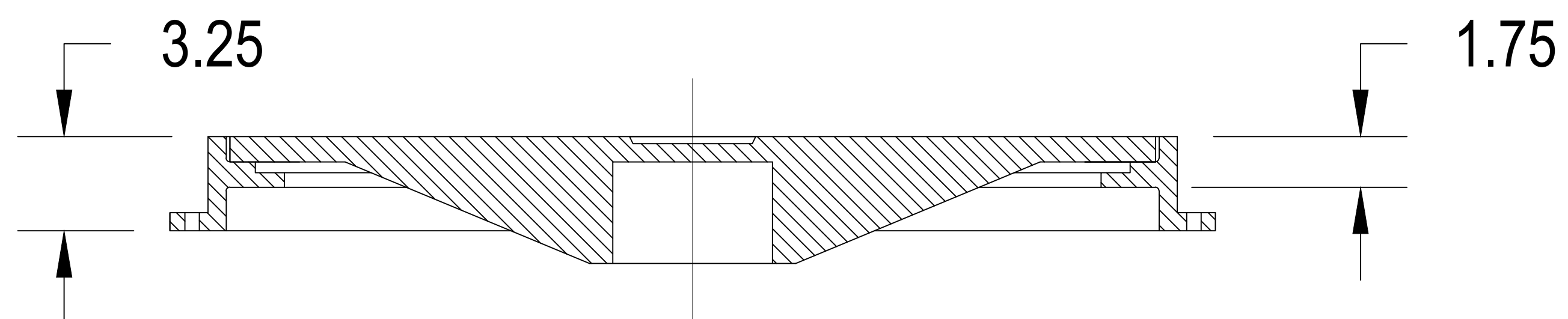

DIMENSIONS ARE FOR REFERENCE ONLY  
 ACTUAL DIMENSIONS MAY VARY  
 DIMENSIONS ARE IN INCHES  
 COVER MEETS H-20 LOAD RATING  
 QUALITY: MATERIALS SHALL CONFORM TO ASTM A536 GRADE 70-50-05  
 PAINT: CASTINGS ARE FURNISHED WITH A BLACK PAINT  
 LOCKING DEVICE AVAILABLE UPON REQUEST SEE DRAWING NO.  
 7001-110-026

ADVANCED DRAINAGE SYSTEMS, INC. ("ADS") HAS PREPARED THIS DETAIL BASED ON INFORMATION PROVIDED TO ADS. THIS DRAWING IS INTENDED TO DEPICT THE COMPONENTS AS REQUESTED. ADS HAS NOT PERFORMED ANY ENGINEERING OR DESIGN SERVICES FOR THIS PROJECT, NOR HAS ADS INDEPENDENTLY VERIFIED THE INFORMATION SUPPLIED. THE INSTALLATION DETAILS PROVIDED HEREIN ARE GENERAL RECOMMENDATIONS AND ARE NOT SPECIFIC FOR THIS PROJECT. THE DESIGN ENGINEER SHALL REVIEW THESE DETAILS PRIOR TO CONSTRUCTION. IT IS THE DESIGN ENGINEERS RESPONSIBILITY TO ENSURE THE DETAILS PROVIDED HEREIN MEETS OR EXCEEDS THE APPLICABLE NATIONAL, STATE, OR LOCAL REQUIREMENTS AND TO ENSURE THAT THE DETAILS PROVIDED HEREIN ARE ACCEPTABLE FOR THIS PROJECT.

STANDARD DETAIL  
 NYLOPLAST 30 IN SOLID  
 COVER ASSEMBLY - TYPE B

DRAWING NUMBER 7001-110-222



4640 TRUEMAN BLVD  
 HILLIARD, OH 43026

DRAWN BY: NMH  
 DATE: 02/06/23  
 OK'S BY:  
 SCALE: NTS  
 SHEET: 1 OF 1



# 3099CGP

APPROX. DRAIN AREA = 277.95 SQ IN  
 APPROX. WEIGHT WITH FRAME = 223.50 LBS

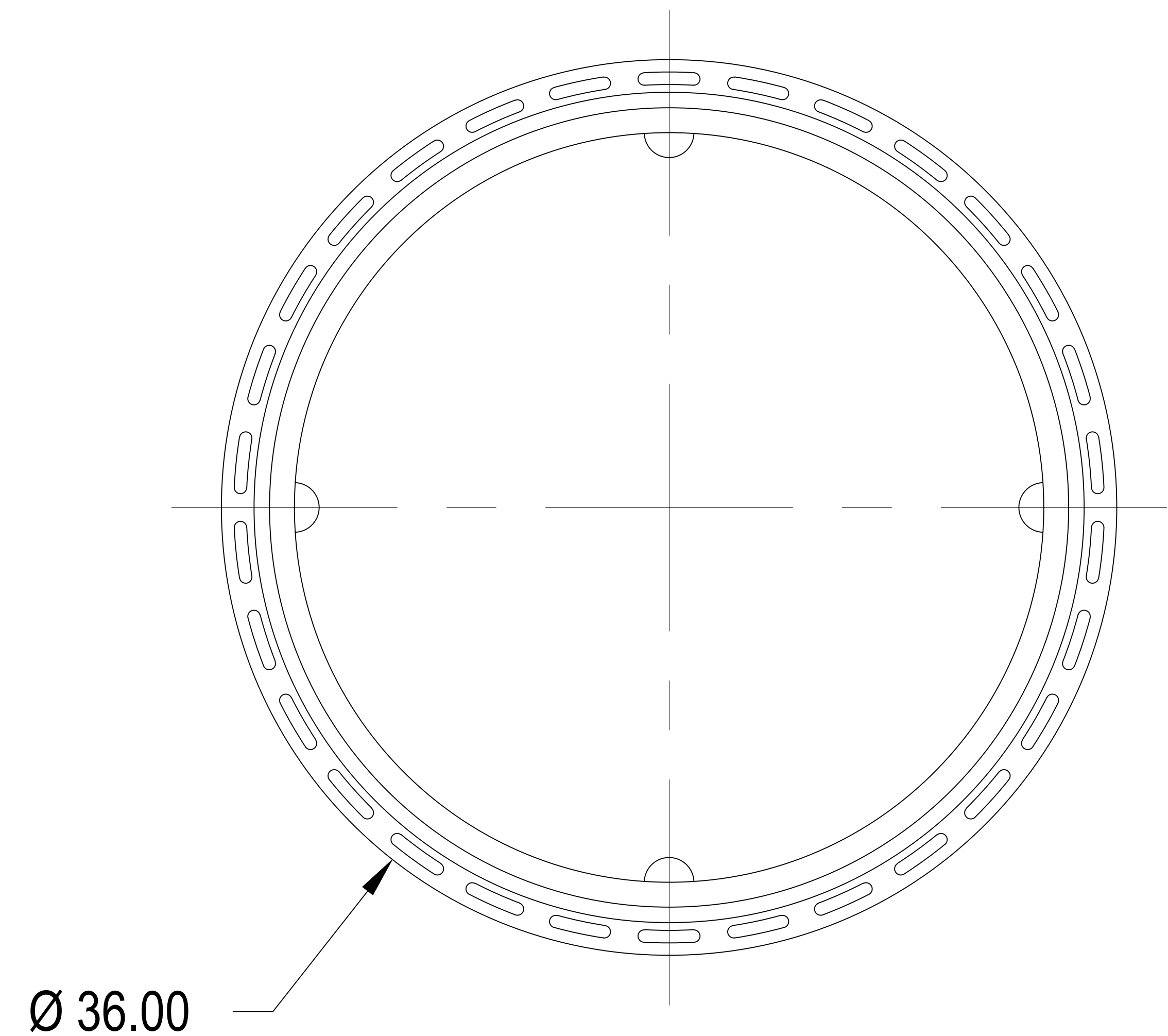
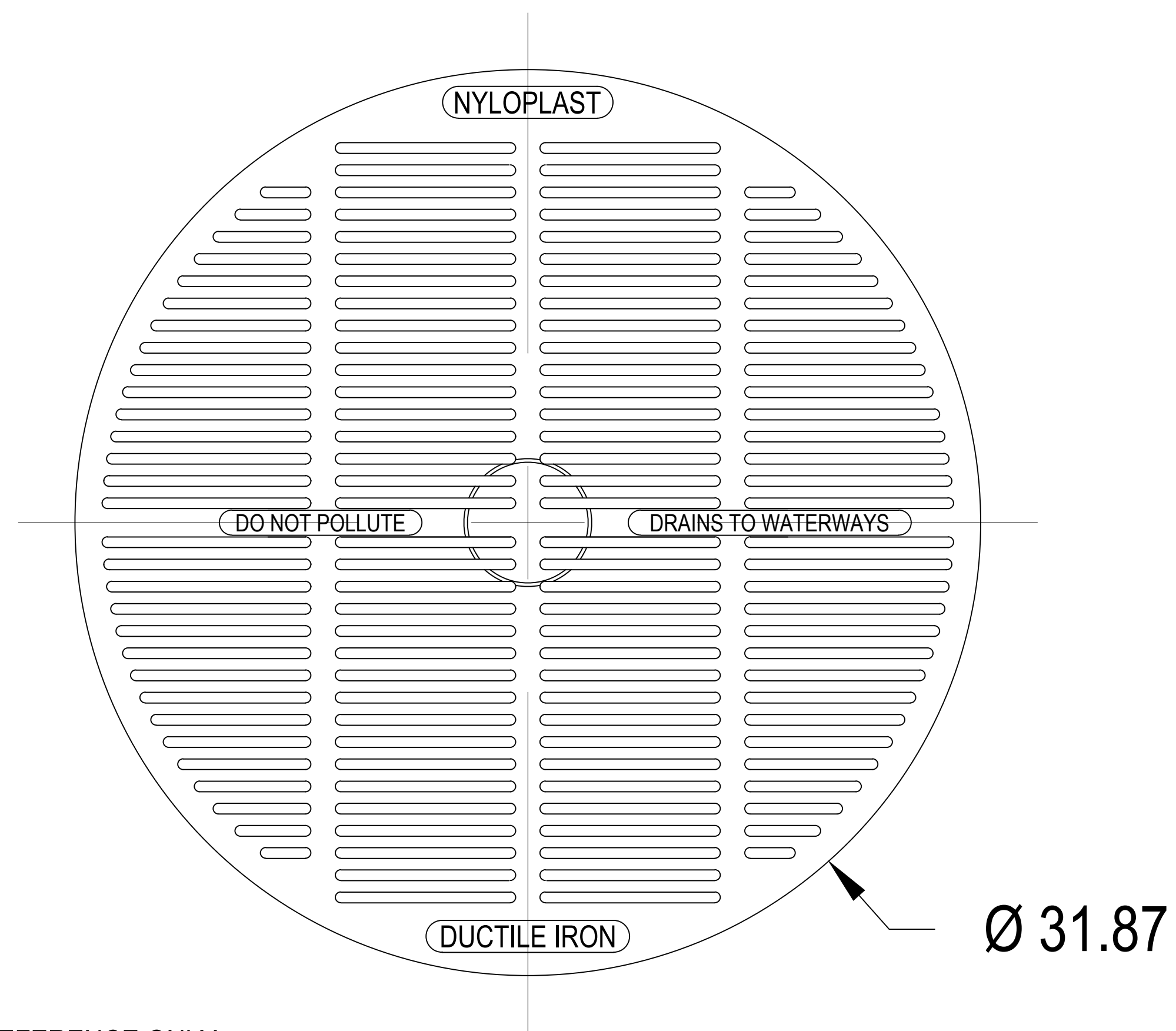
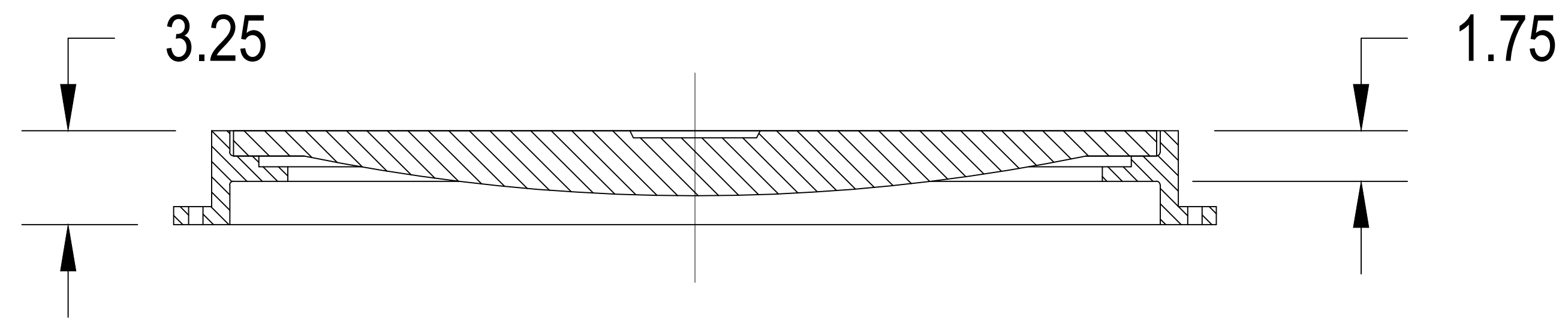

DIMENSIONS ARE FOR REFERENCE ONLY  
 ACTUAL DIMENSIONS MAY VARY  
 DIMENSIONS ARE IN INCHES  
 GRATE MEETS H-20 LOAD RATING  
 QUALITY: MATERIALS SHALL CONFORM TO ASTM A536 GRADE 70-50-05  
 PAINT: CASTINGS ARE FURNISHED WITH A BLACK PAINT  
 SIZE OF OPENING MEETS REQUIREMENTS OF AMERICAN DISABILITY  
 ACT AS STATED IN FEDERAL REGISTER PART III, DEPARTMENT OF  
 JUSTICE, 28 CFR PART 36.  
 LOCKING DEVICE AVAILABLE UPON REQUEST SEE DRAWING NO.  
 7001-110-232

ADVANCED DRAINAGE SYSTEMS, INC. ("ADS") HAS PREPARED THIS DETAIL BASED ON INFORMATION PROVIDED TO ADS. THIS DRAWING IS INTENDED TO DEPICT THE COMPONENTS AS REQUESTED. ADS HAS NOT PERFORMED ANY ENGINEERING OR DESIGN SERVICES FOR THIS PROJECT, NOR HAS ADS INDEPENDENTLY VERIFIED THE INFORMATION SUPPLIED. THE INSTALLATION DETAILS PROVIDED HEREIN ARE GENERAL RECOMMENDATIONS AND ARE NOT SPECIFIC FOR THIS PROJECT. THE DESIGN ENGINEER SHALL REVIEW THESE DETAILS PRIOR TO CONSTRUCTION. IT IS THE DESIGN ENGINEERS RESPONSIBILITY TO ENSURE THE DETAILS PROVIDED HEREIN MEETS OR EXCEEDS THE APPLICABLE NATIONAL, STATE, OR LOCAL REQUIREMENTS AND TO ENSURE THAT THE DETAILS PROVIDED HEREIN ARE ACCEPTABLE FOR THIS PROJECT.

STANDARD DETAIL  
 NYLOPLAST 30 IN PEDESTRIAN  
 GRATE ASSEMBLY

DRAWING NUMBER 7001-110-220



4640 TRUEMAN BLVD  
 HILLIARD, OH 43026

DRAWN BY: NMH  
 DATE: 02/06/23  
 OK'S BY:  
 SCALE: NTS  
 SHEET: 1 OF 1