

NYLOPLAST 2 FT X 2FT ROAD & HIGHWAY STRUCTURE: 32 __ AGS __ X

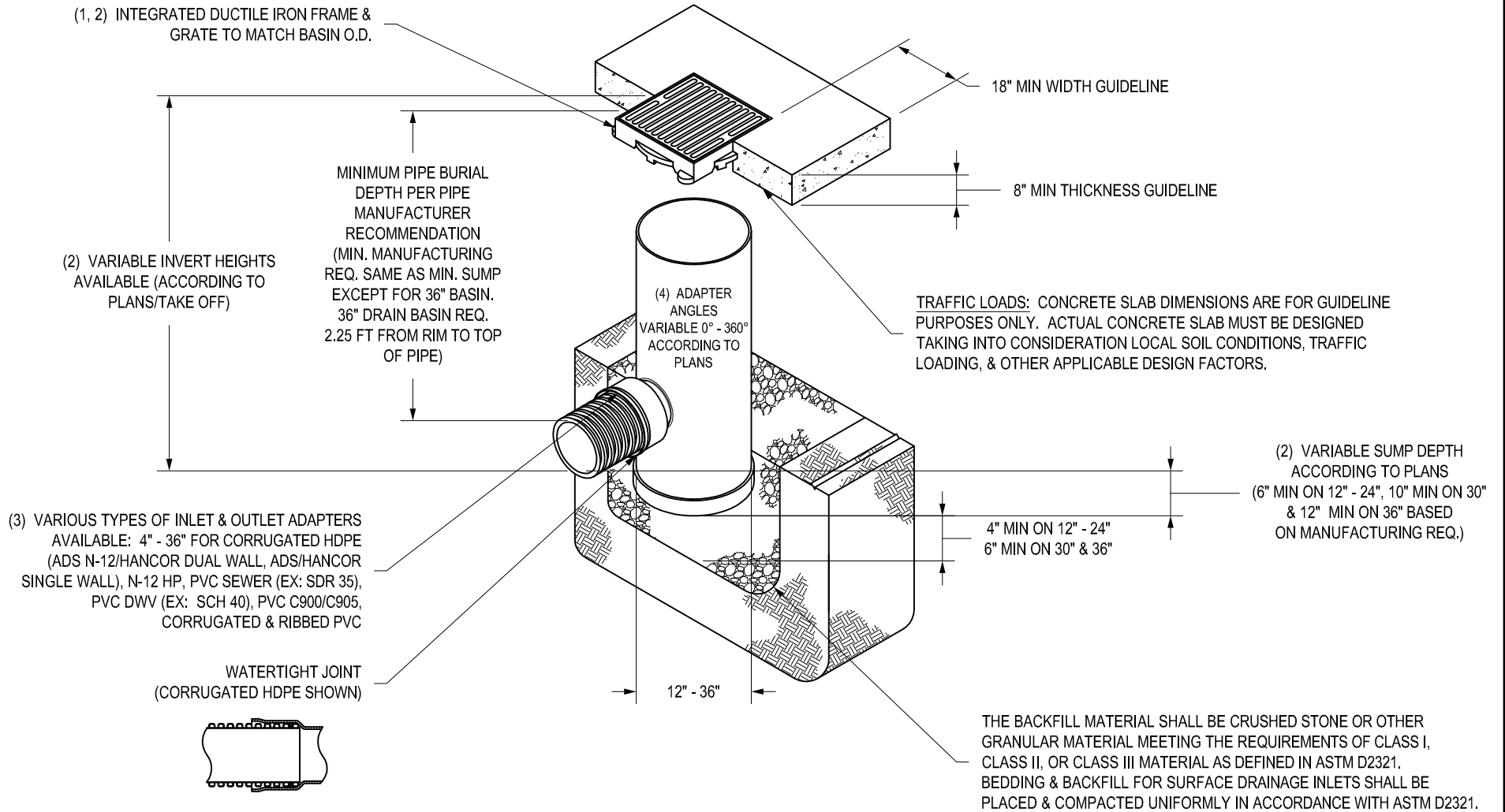

- 1 - 12" - 30" FRAMES & GRATES SHALL BE DUCTILE IRON PER ASTM A536 GRADE 70-50-05.
- 2 - DRAIN BASIN TO BE CUSTOM MANUFACTURED ACCORDING TO PLAN DETAILS.
- 3 - DRAINAGE CONNECTION STUB JOINT TIGHTNESS SHALL CONFORM TO ASTM D3212 FOR CORRUGATED HDPE (ADS N-12/HANCOR DUAL WALL), N-12 HP, & PVC SEWER (4" - 36").
- 4 - ADAPTERS CAN BE MOUNTED ON ANY ANGLE 0° TO 360°. TO DETERMINE MINIMUM ANGLE BETWEEN ADAPTERS SEE DRAWING NO. 7001-110-012.
- 5 - ROAD & HIGHWAY GRATE SHALL MEET H-20 LOAD RATING.

THIS PRINT DISCLOSES SUBJECT MATTER IN WHICH NYLOPLAST HAS PROPRIETARY RIGHTS. THE RECEIPT OR POSSESSION OF THIS PRINT DOES NOT CONFER, TRANSFER, OR LICENSE THE USE OF THE DESIGN OR TECHNICAL INFORMATION SHOWN HEREIN REPRODUCTION OF THIS PRINT OR ANY INFORMATION CONTAINED HEREIN, OR MANUFACTURE OF ANY ARTICLE HEREFROM, FOR THE DISCLOSURE TO OTHERS IS FORBIDDEN, EXCEPT BY SPECIFIC WRITTEN PERMISSION FROM NYLOPLAST.

©2013 NYLOPLAST

DRAWN BY	EBC	MATERIAL	
DATE	1-23-06	PROJECT NO./NAME	
REVISED BY	NMH	SCALE	1:40
DATE	7-22-19	SHEET	1 OF 1
DWG SIZE	A		



ADS
Nyloplast

3130 VERONA AVE
BUFORD, GA 30518
PHN (770) 932-2443
FAX (770) 932-2490
www.nyloplast-us.com

TITLE	DRAIN BASIN WITH 2 FT X 2 FT ROAD & HIGHWAY GRATE QUICK SPEC INSTALLATION DETAIL
DWG NO.	7001-110-162
REV	H