

# SC-310 TECHNICAL SPECIFICATION

NTS

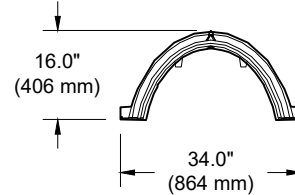
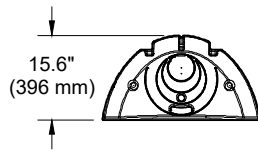
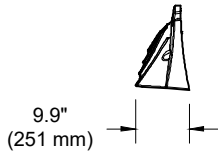
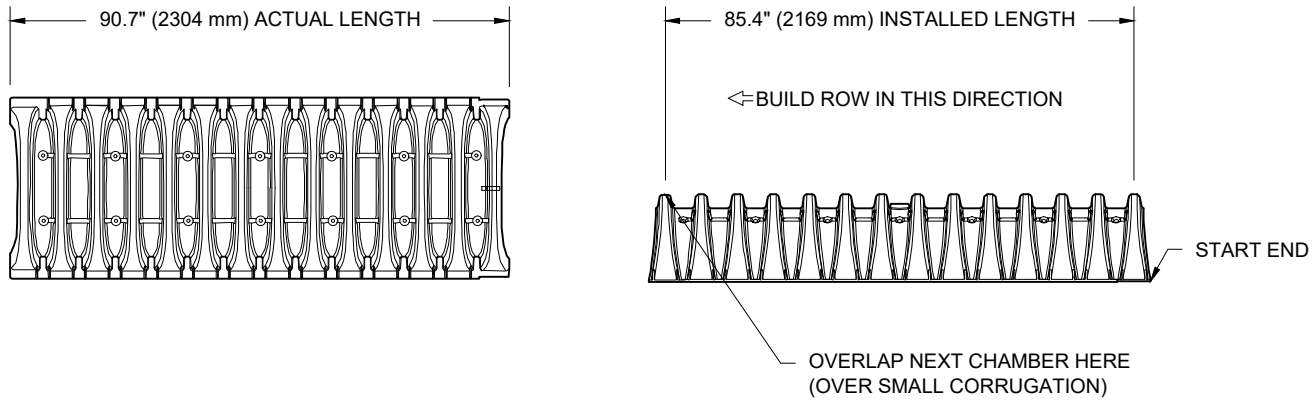

### NOMINAL CHAMBER SPECIFICATIONS

SIZE (W X H X INSTALLED LENGTH)	34.0" X 16.0" X 85.4"	(864 mm X 406 mm X 2169 mm)
CHAMBER STORAGE	14.7 CUBIC FEET	(0.42 m <sup>3</sup> )
MINIMUM INSTALLED STORAGE*	29.34 CUBIC FEET	(0.83 m <sup>3</sup> )
WEIGHT	35.0 lbs.	(16.8 kg)

\*ASSUMES 6" (150 mm) ABOVE AND BELOW CHAMBER; 3" (75 mm) BETWEEN CHAMBERS

PART #	STUB	B	C
SC310EPE06TPC	6" (150 mm)	5.8" (147 mm)	---
SC310EPE06BPC		---	0.5" (13 mm)
SC310EPE08TPC	8" (200 mm)	3.5" (89 mm)	---
SC310EPE08BPC		---	0.6" (15 mm)
SC310EPE10TPC	10" (250 mm)	1.4" (36 mm)	---
SC310EPE10BPC		---	0.7" (18 mm)
SC310ECEZ*	12" (300 mm)	---	0.9" (23 mm)

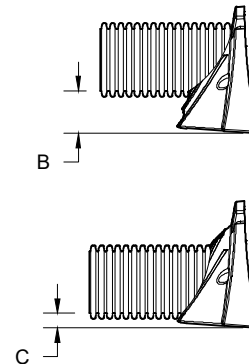

ALL STUBS, EXCEPT FOR THE SC310ECEZ ARE PLACED AT BOTTOM OF END CAP SUCH THAT THE OUTSIDE DIAMETER OF THE STUB IS FLUSH WITH THE BOTTOM OF THE END CAP. FOR ADDITIONAL INFORMATION CONTACT STORMTECH AT 1-888-892-2694.

\* FOR THE SC310ECEZ THE 12" (300 mm) STUB LIES BELOW THE BOTTOM OF THE END CAP APPROXIMATELY 0.25" (6 mm). BACKFILL MATERIAL SHOULD BE REMOVED FROM BELOW THE N-12 STUB SO THAT THE FITTING SITS LEVEL.

NOTE: ALL DIMENSIONS ARE NOMINAL; PRE-CORED END CAPS END WITH "PC"

TECHNICAL SPECIFICATIONS  
SC-310 CHAMBER

DATE: 01/15/25  
DRAWING #: 721-310  
DRAWN: SMW  
CHECKED: JLM

1-800-821-6710  
WWW.STORMTECH.COM

**StormTech**<sup>®</sup>  
Chamber System

4640 TRUEMAN BLVD  
HILLIARD, OH 43026

**ADS**

THIS DRAWING HAS BEEN PREPARED BASED ON INFORMATION PROVIDED TO ADS/STORMTECH UNDER THE DIRECTION OF THE PROJECT'S ENGINEER OF RECORD (EOR) OR OTHER PROJECT REPRESENTATIVE. THIS DRAWING IS NOT INTENDED FOR USE IN BIDDING OR CONSTRUCTION WITHOUT THE EOR'S PRIOR APPROVAL. EOR SHALL REVIEW THIS DRAWING PRIOR TO BIDDING AND/OR CONSTRUCTION. IT IS THE ULTIMATE RESPONSIBILITY OF THE EOR TO ENSURE THAT THE PRODUCT(S) DEPICTED AND ALL ASSOCIATED DETAILS MEET ALL APPLICABLE LAWS, REGULATIONS, AND PROJECT REQUIREMENTS.