

SC-310 TECHNICAL SPECIFICATION

NTS

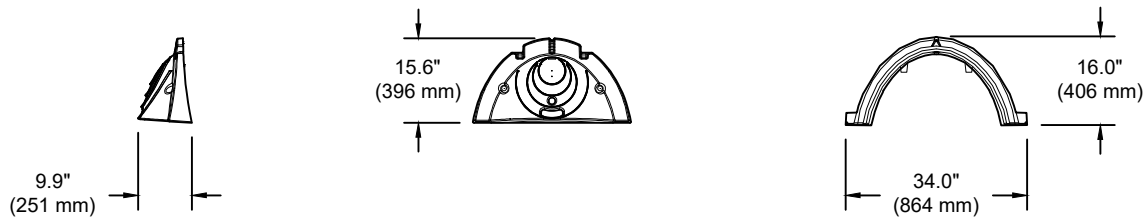
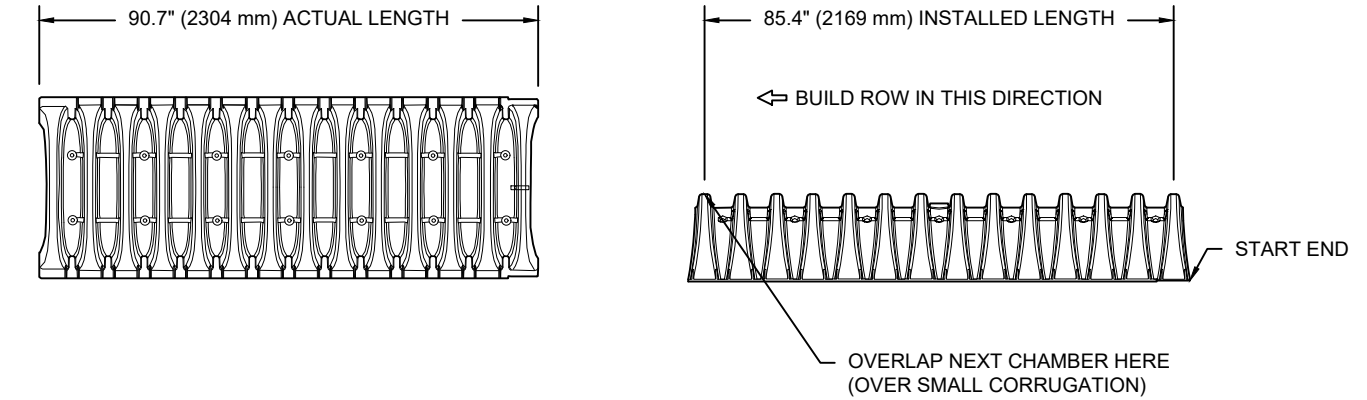

NOMINAL CHAMBER SPECIFICATIONS

SIZE (W X H X INSTALLED LENGTH)	34.0" X 16.0" X 85.4"	(864 mm X 406 mm X 2169 mm)
CHAMBER STORAGE	14.7 CUBIC FEET	(0.42 m ³)
MINIMUM INSTALLED STORAGE*	31.0 CUBIC FEET	(0.88 m ³)
WEIGHT	35.0 lbs.	(16.8 kg)

*ASSUMES 6" (152 mm) ABOVE, BELOW, AND BETWEEN CHAMBERS

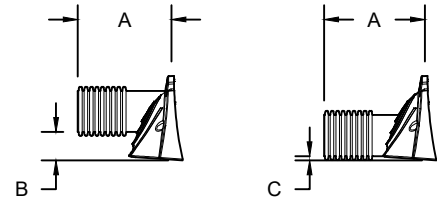

PRE-FAB STUBS AT BOTTOM OF END CAP FOR PART NUMBERS ENDING WITH "B"
 PRE-FAB STUBS AT TOP OF END CAP FOR PART NUMBERS ENDING WITH "T"
 PRE CORED END CAPS END WITH "PC"

PART #	STUB	A	B	C
SC310EPE06T / SC310EPE06TPC	6" (150 mm)	9.6" (244 mm)	5.8" (147 mm)	---
SC310EPE06B / SC310EPE06BPC			---	0.5" (13 mm)
SC310EPE08T / SC310EPE08TPC	8" (200 mm)	11.9" (302 mm)	3.5" (89 mm)	---
SC310EPE08B / SC310EPE08BPC			---	0.6" (15 mm)
SC310EPE10T / SC310EPE10TPC	10" (250 mm)	12.7" (323 mm)	1.4" (36 mm)	---
SC310EPE10B / SC310EPE10BPC			---	0.7" (18 mm)
SC310ECEZ*	12" (300 mm)	13.5" (343 mm)	---	0.9" (23 mm)

ALL STUBS, EXCEPT FOR THE SC310ECEZ ARE PLACED AT BOTTOM OF END CAP SUCH THAT THE OUTSIDE DIAMETER OF THE STUB IS FLUSH WITH THE BOTTOM OF THE END CAP. FOR ADDITIONAL INFORMATION CONTACT STORMTECH AT 1-888-892-2694.

* FOR THE SC310ECEZ THE 12" (300 mm) STUB LIES BELOW THE BOTTOM OF THE END CAP APPROXIMATELY 0.25" (6 mm). BACKFILL MATERIAL SHOULD BE REMOVED FROM BELOW THE N-12 STUB SO THAT THE FITTING SITS LEVEL.

NOTE: ALL DIMENSIONS ARE NOMINAL