

**NOTES:**

1. CONNECTION AND PIPE TO BE BACKFILLED PER ASTM D2321, LATEST EDITION.
2. AN INTERNAL CYLINDER MAY BE WELDED TO THE PIPE TO BE INSERTED INTO THE ID OF THE EXISTING PIPE AND MINIMIZE JOINT MOVEMENT. HOWEVER, AN INTERNAL CYLINDER IS NOT RECOMMENDED FOR DOWNSTREAM CONNECTIONS.

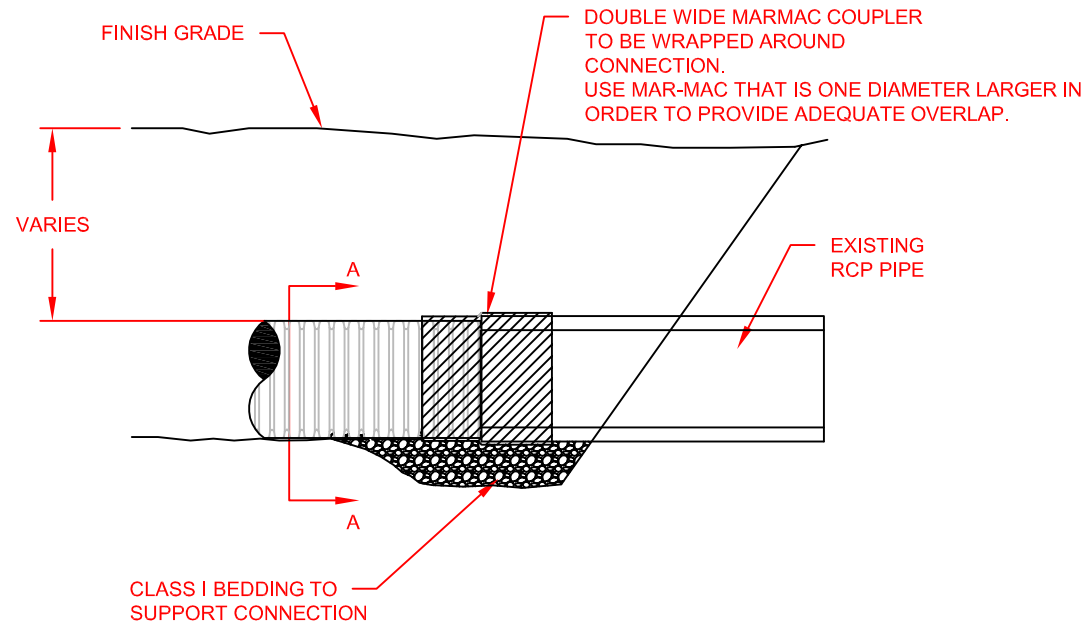

DOUBLE WIDE MARMAC COUPLER TO BE WRAPPED AROUND CONNECTION

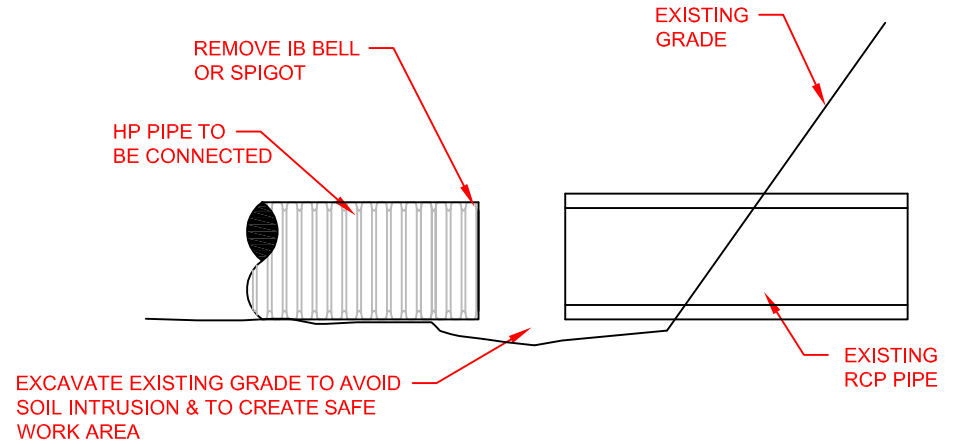
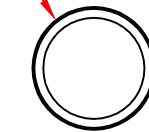

SECTION "A-A"

© 2016 ADS, INC.

ADVANCED DRAINAGE SYSTEMS, INC. ("ADS") HAS PREPARED THIS DETAIL BASED ON INFORMATION PROVIDED TO ADS. THIS DRAWING IS INTENDED TO DEPICT THE COMPONENTS AS REQUESTED. ADS HAS NOT PERFORMED ANY ENGINEERING OR DESIGN SERVICES FOR THIS PROJECT, NOR HAS ADS INDEPENDENTLY VERIFIED THE INFORMATION SUPPLIED. THE INSTALLATION DETAILS PROVIDED HEREIN ARE GENERAL RECOMMENDATIONS AND ARE NOT SPECIFIC FOR THIS PROJECT. THE DESIGN ENGINEER SHALL REVIEW THESE DETAILS PRIOR TO CONSTRUCTION. IT IS THE DESIGN ENGINEERS RESPONSIBILITY TO ENSURE THE DETAILS PROVIDED HEREIN MEETS OR EXCEEDS THE APPLICABLE NATIONAL, STATE, OR LOCAL REQUIREMENTS AND TO ENSURE THAT THE DETAILS PROVIDED HEREIN ARE ACCEPTABLE FOR THIS PROJECT.

1	RENAMED AND RENUMBERED	TJR	02/19/16	
REV.	DESCRIPTION	BY	MM/DD/YY	CHK'D

**SANITITE HP TO RCP CONNECTION (MARMAC)**

DRAWING NUMBER: **STD-604B**



4640 TRUEMAN BLVD  
HILLIARD, OHIO 43026

DRAWN BY:	CKM
DATE:	5/26/10
CHK'D BY:	
SCALE:	NTS
SHEET:	1 OF 1