

THE ECOSTREAM BIOFILTER™ IS A BIOFILTRATION STORMWATER TREATMENT TECHNOLOGY THAT RELIES ON PHYSICAL, CHEMICAL AND BIOLOGICAL MECHANISMS TO REMOVE TOTAL SUSPENDED SOLIDS, TOTAL PHOSPHORUS, TOTAL NITROGEN, HEAVY METALS, OIL AND GREASE, TRASH AND BACTERIA.

Model	Filter Bay Size (ft)	Media Filtration Area (sf)	Overflow to Outlet Depth (in)	Design Treatment Rate (cfs)	Outlet Assembly Diameter (in)	Solid Lid Size & Number
ES16E	4 x 4	16	32	0.111	6	36 in (1x)
ES24E	4 x 6	24	32	0.167	6	36 in (1x)
ES32E	4 x 8	32	32	0.223	6	36 in (1x)
ES36E	6 x 6	36	32	0.251	6	36 in (1x)
ES40E	4 x 10	40	32	0.279	6	36 in (2x)
ES48E	4 x 12	48	32	0.334	6	36 in (2x)
ES48E	6 x 8	48	32	0.334	6	36 in (1x)
ES60E	6 x 10	60	32	0.418	8	36 in (1x)
ES72E	6 x 12	72	32	0.501	8	36 in (2x)
ES80E	8 x 10	80	32	0.557	8	36 in (1x)
ES96E	8 x 12	96	32	0.668	10	36 in (2x)
ES112E	8 x 14	112	32	0.780	10	36 in (2x)
ES128E	8 x 16	128	32	0.891	10	36 in (2x)

NOTES:

- UNDERDRAIN SHOWN IS SCHEMATIC ONLY. FOR DETAILS ON UNDERDRAIN SIZING AND LAYOUT SEE ECOSTREAM INSTALLATION GUIDE FOR DETAILS, KIT NUMBER AND PLACEMENT OPTIONS.
- WSDOE GULD APPROVAL APPLIES TO PLANTED OR PLANTLESS ECOSTREAM SYSTEMS.
- OPTIONAL FLEXSTORM INSERT TO MEET CASQA FTC REQUIREMENTS.

ADS ECOSTREAM SPECIFICATIONS

PRODUCTS

- A. INTERNAL COMPONENTS: SHALL BE SUBSTANTIALLY CONSTRUCTED OF RECYCLED POLYETHYLENE OR OTHER THERMOPLASTIC MATERIAL APPROVED BY THE MANUFACTURER
- B. FILTER MEDIA/VEGETATION: FILTER MEDIA SHALL BE BY ADS AND SHALL CONSIST OF A PROPRIETARY BLEND OF FILTER MEDIA. VEGETATION IS VARIABLE DEPENDENT ON REGION. ITEMS CHOSEN SHOULD ALIGN WITH CONTROLLING MUNICIPAL, COUNTY, OR STATE REQUIREMENTS.
- C. PRECAST CONCRETE VAULT: DESIGNED FOR H-20 TRAFFIC LOADING AND APPLICABLE SOIL LOADS OR AS OTHERWISE DETERMINED BY A LICENSED PROFESSIONAL ENGINEER. THE MATERIALS AND STRUCTURAL DESIGN OF THE DEVICES SHALL BE PER ASTM C478, ASTM C857 AND ASTM C858.

PERFORMANCE

- A. THE STORMWATER FILTER SYSTEM SHALL BE AN ONLINE OR OFFLINE DESIGN BASED ON LOCAL REQUIREMENTS CAPABLE OF TREATING 100% OF THE REQUIRED TREATMENT FLOW AT FULL SEDIMENT LOAD CONDITIONS.
- B. THE STORMWATER FILTER SYSTEM SHALL HAVE NO MOVING PARTS.
- C. THE STORMWATER TREATMENT UNIT SHALL BE DESIGNED TO REMOVE AT LEAST 80% OF SUSPENDED SOLIDS, 62% TOTAL PHOSPHORUS, 35% DISSOLVED COPPER, AND 61% DISSOLVED ZINC.
 - SIZED AT A HYDRAULIC LOADING RATE OF NO MORE THAN 3.125 GALLONS PER MINUTE PER SQUARE FOOT OF MEDIA SURFACE.
 - CONSTRUCTED WITH A MINIMUM MEDIA THICKNESS OF 5 INCHES OF GROWTH MEDIA AND 15 INCHES OF BIOFILTRATION MEDIA.

ECOSTREAM INSTALLATION NOTES

INSTALLATION OF THE STORMWATER TREATMENT UNIT(S) SHALL BE PERFORMED PER MANUFACTURER'S INSTALLATION INSTRUCTIONS. SUCH INSTRUCTIONS CAN BE OBTAINED BY CALLING ADVANCED DRAINAGE SYSTEMS AT (800) 821-6710 OR BY LOGGING ON TO WWW.ADS-PIPE.COM.

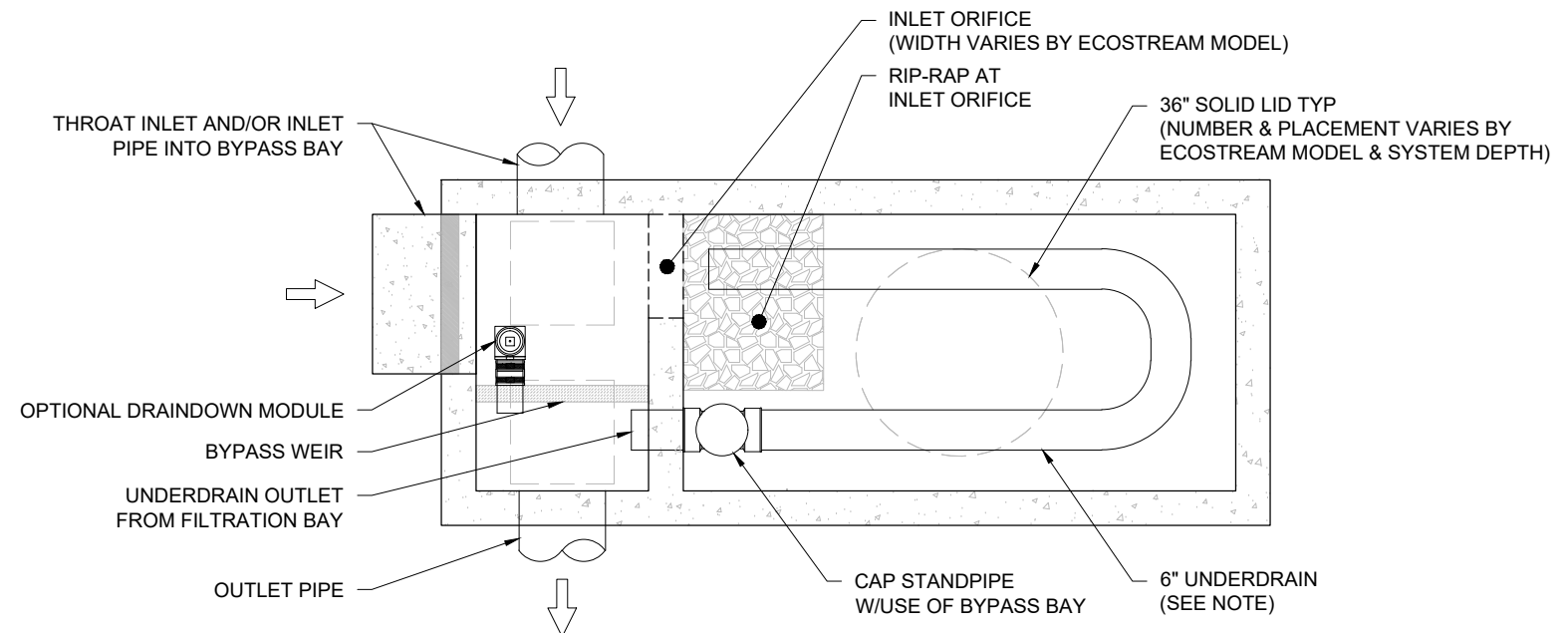

ECOSTREAM PLAN VIEW WITH SOLID LID
NOT TO SCALE

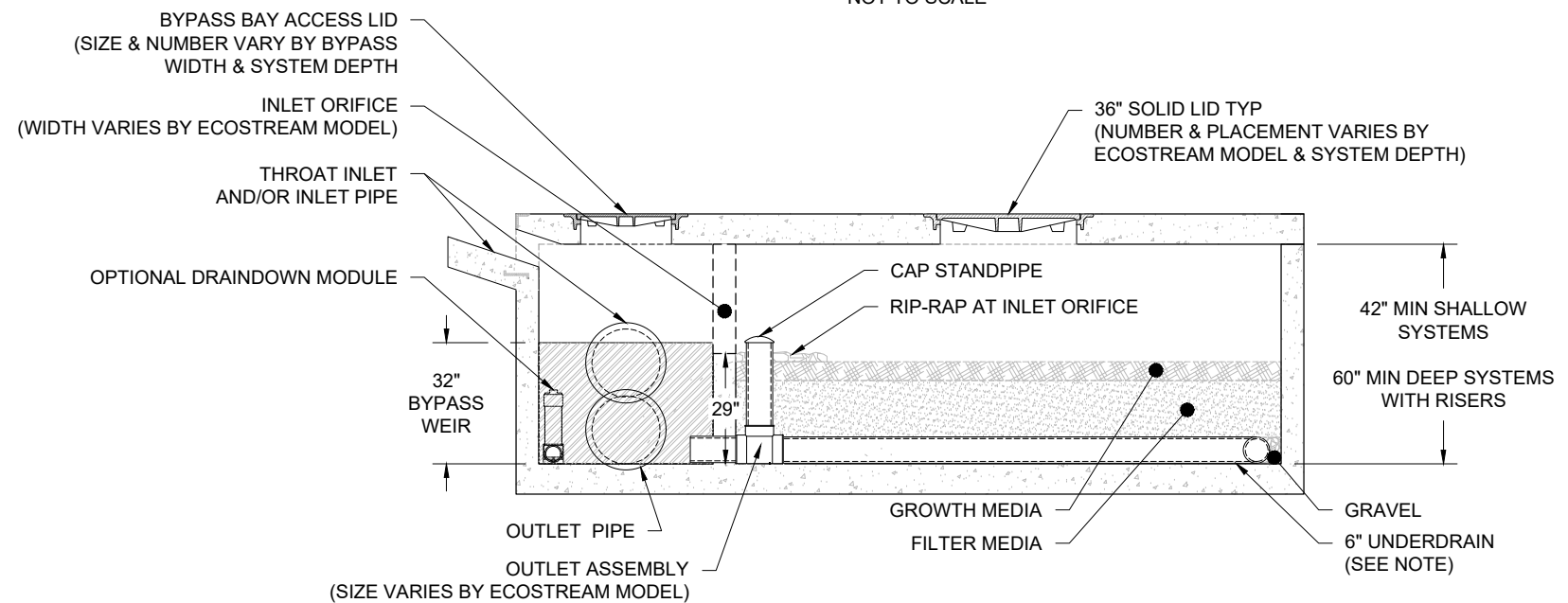

ECOSTREAM PROFILE VIEW WITH SOLID LID
NOT TO SCALE

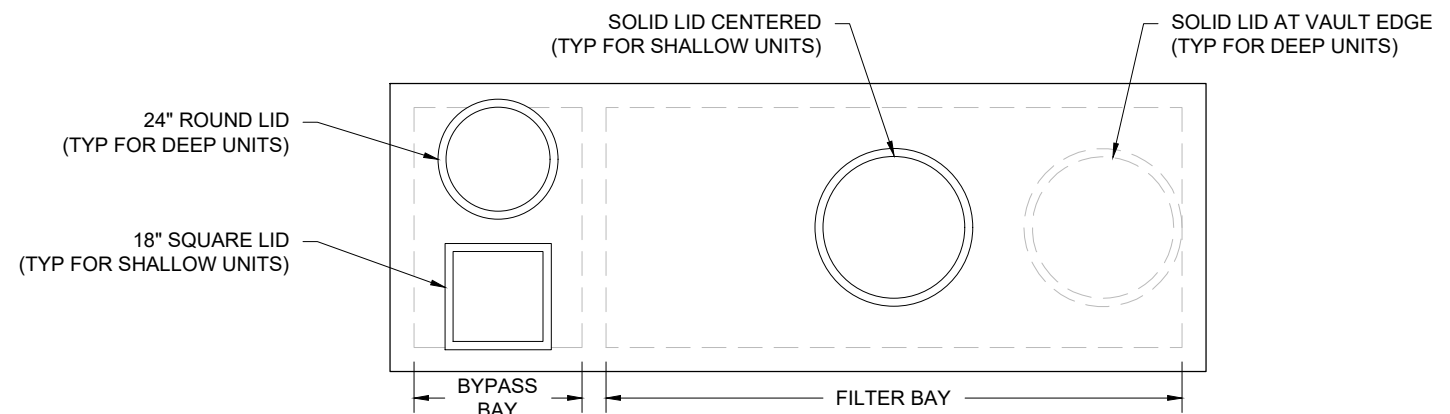

SOLID LID PLACEMENT
SIZE AND NUMBER OF SOLID LIDS VARY BY ECOSTREAM MODEL & SYSTEM DEPTH

ECOSTREAM BIOFILTER W/BYPASS
SOLID LID INSTALLATION
ENHANCED MEDIA

DATE: 09/05/24
DRAWN: JLM
CHECKED: SMW

DATE	DESCRIPTION
09/20/24	UPDATED TREATMENT RATES
09/12/24	4X8X4X10
JLM	JLM
JLM	JLM
JLM	DRWN
JLM	CHKD

EcoStream™ Biofilter
Stormwater Media Filters

4640 TRUEMAN BLVD
HILLIARD, OH 43026

ADS

THIS DRAWING HAS BEEN PREPARED BASED ON INFORMATION PROVIDED TO ADS/STORMTECH UNDER THE DIRECTION OF THE PROJECT'S ENGINEER OF RECORD (EOR) OR OTHER PROJECT REPRESENTATIVE. THIS DRAWING IS NOT INTENDED FOR USE IN BIDDING OR CONSTRUCTION WITHOUT THE EOR'S PRIOR APPROVAL. EOR SHALL REVIEW THIS DRAWING PRIOR TO BIDDING AND/OR CONSTRUCTION. IT IS THE ULTIMATE RESPONSIBILITY OF THE EOR TO ENSURE THAT THE PRODUCT(S) DEPICTED AND ALL ASSOCIATED DETAILS MEET ALL APPLICABLE LAWS, REGULATIONS, AND PROJECT REQUIREMENTS.