

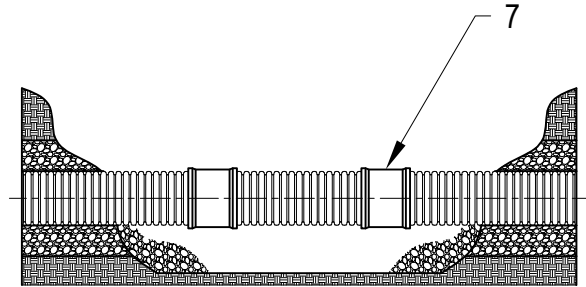

INSTALLATION GUIDELINES:

1. EXCAVATE AROUND THE DAMAGED PIPE.
2. CHECK REPAIR COMPONENTS
 - A. TWO NYLOPLAST PVC REPAIR COUPLERS
 - B. FOUR ADS SADDLE GASKETS
 - C. REPLACEMENT SECTION OF PIPE
3. CUT AND REMOVE THE SECTION OF DAMAGED PIPE. CUT THE PIPE IN A VALLEY OF A CORRUGATION EQUAL TO THE REPLACEMENT LENGTH.
4. SLIDE THE NYLOPLAST PVC REPAIR COUPLERS ON TO THE EXISTING LINE OF PIPE.
5. INSTALL THE SADDLE GASKETS ON THE FIRST CORRUGATION ON EACH SIDE OF EACH CONNECTION.
6. THE GASKETS SHOULD BE BOTH POSITIONED FACING THE NYLOPLAST PVC REPAIR COUPLER. REFER TO GASKET INSTALLATION INSTRUCTIONS FOR PROPER INSTALLATION DIRECTION.
7. SLIDE THE NYLOPLAST PVC REPAIR COUPLER OVER BOTH GASKETS TO COMPLETE THE JOINT.
8. BACKFILL THE REPAIRED PIPE PER THE MANUFACTURERS GUIDELINES.

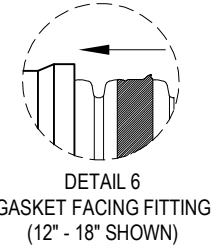
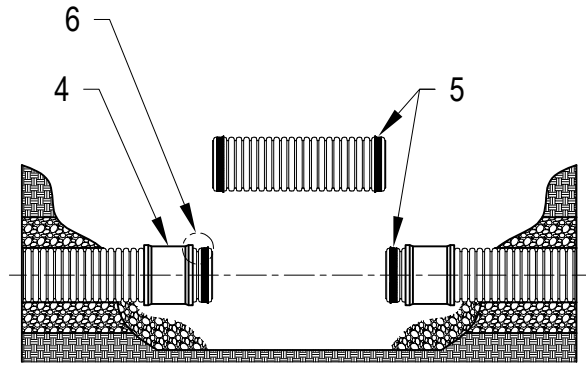
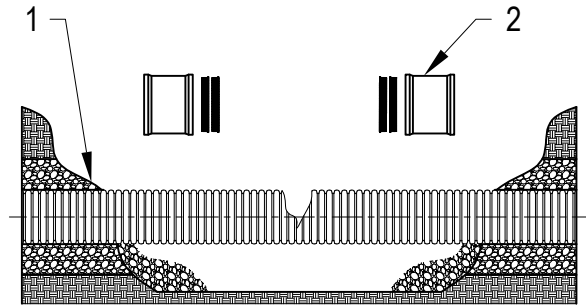

THIS PRINT DISCLOSES SUBJECT MATTER IN WHICH NYLOPLAST HAS PROPRIETARY RIGHTS. THE RECEIPT OR POSSESSION OF THIS PRINT DOES NOT CONFER, TRANSFER, OR LICENSE THE USE OF THE DESIGN OR TECHNICAL INFORMATION SHOWN HEREIN REPRODUCTION OF THIS PRINT OR ANY INFORMATION CONTAINED HEREIN, OR MANUFACTURE OF ANY ARTICLE HEREFROM, FOR THE DISCLOSURE TO OTHERS IS FORBIDDEN, EXCEPT BY SPECIFIC WRITTEN PERMISSION FROM NYLOPLAST. ©2024 NYLOPLAST	DRAWN BY	JJC	MATERIAL			 3130 VERONA AVE BUFORD, GA 30518 PHN (770) 932-2443 FAX (770) 932-2490 www.nyloplast-us.com		
	DATE	9-19-24	PROJECT NO./NAME					
	APPD BY	NMH	DATE			TITLE		
	DATE	9-19-24	DWG NO.			0150-110-002		
	DWG SIZE	A	SCALE	NTS	SHEET	1 OF 1	REV	B