

DUAL WALL FABRICATED REDUCING SADDLE TEE
8" - 15" DIAMETER

PART #	PIPE SIZE	A	B
** 0841AN	8 x 4 in (200 x 100 mm)	6.4 in (163 mm)	6.0 in (152 mm)
** 0841AN	8 x 6 in (200 x 150 mm)	7.8 in (198 mm)	6.0 in (152 mm)
** 1040AN	10 x 4 in (250 x 100 mm)	6.2 in (157 mm)	5.5 in (140 mm)
** 1041AN	10 x 6 in (250 x 150 mm)	7.7 in (196 mm)	11.0 in (279 mm)
** 1042AN	10 x 8 in (250 x 200 mm)	11.0 in (279 mm)	11.0 in (279 mm)
1240AN	12 x 4 in (300 x 100 mm)	5.8 in (147 mm)	7.8 in (197 mm)
1241AN	12 x 6 in (300 x 150 mm)	7.2 in (183 mm)	7.8 in (197 mm)
1242AN	12 x 8 in (300 x 200 mm)	10.6 in (269 mm)	15.8 in (400 mm)
1540AN	15 x 4 in (375 x 100 mm)	5.7 in (145 mm)	10.5 in (267 mm)
1541AN	15 x 6 in (375 x 150 mm)	7.1 in (180 mm)	10.5 in (267 mm)
1542AN	15 x 8 in (375 x 200 mm)	10.4 in (264 mm)	10.5 in (267 mm)

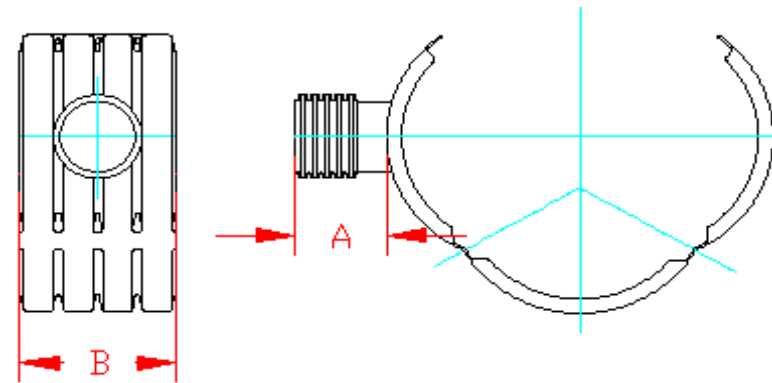

** LIMITED AVAILABILITY. PLEASE SEE INJECTION MOLDED FITTING SECTION FOR OTHER AVAILABLE FITTINGS

NOTE: ALL FITTINGS DIMENSIONS ARE FOR REFERENCE ONLY

© 2023 Advanced Drainage Systems, Inc.

	DRAWING #:	2460	
	DRAWN BY:	JCB	04.06.06
	APPROVED BY:	JCB	06.26.07
	REVISIONS:	TJR	5/19/2010