

3099CGRHF & 3099CGRFHR

APPROX. GRATE DRAIN AREA = 327.25 SQ IN
 *APPROX. WEIGHT WITH FRAME & HOOD = 335.00 LBS

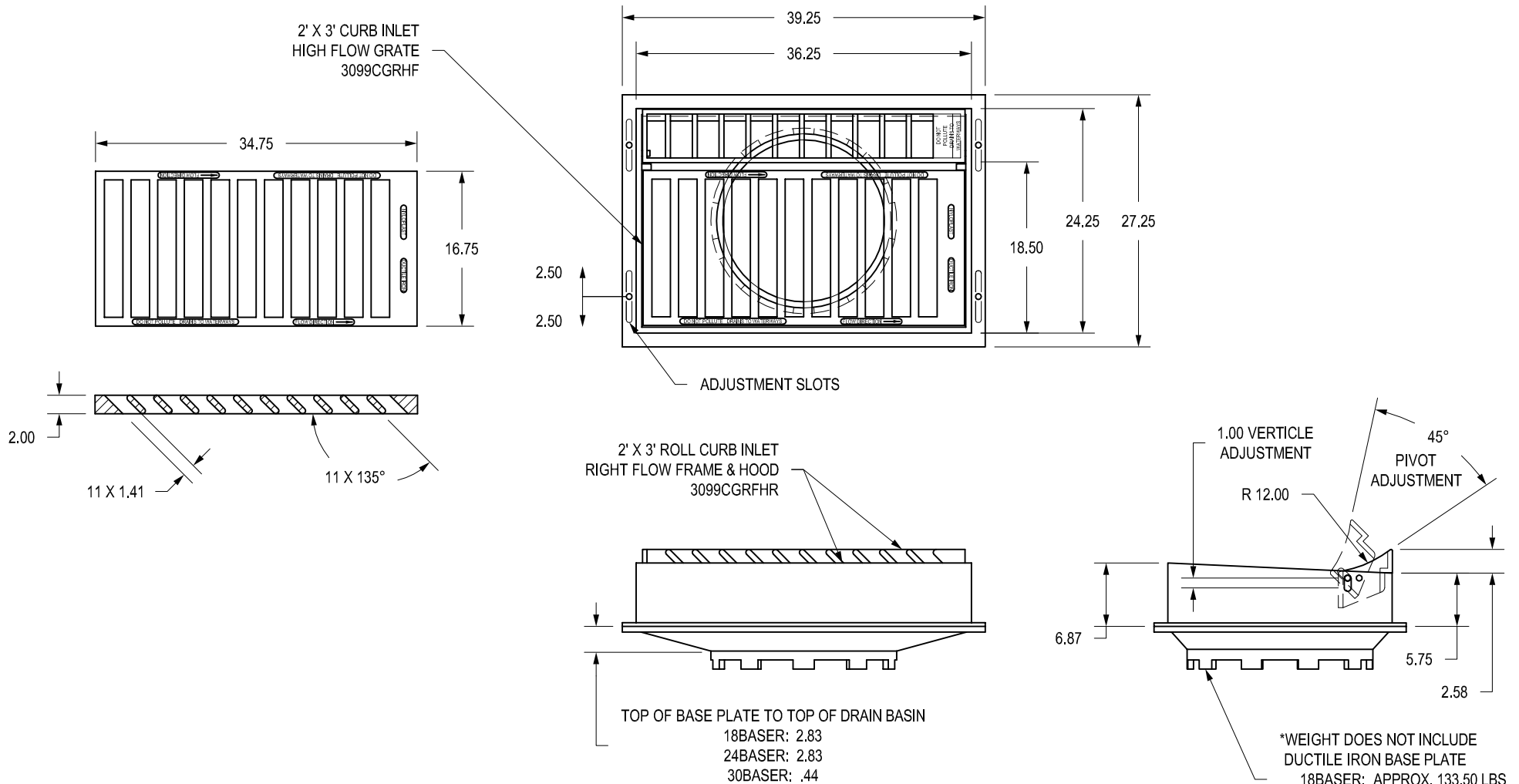

*WEIGHT DOES NOT INCLUDE
 DUCTILE IRON BASE PLATE
 18BASER: APPROX. 133.50 LBS
 24BASER: APPROX. 122.00 LBS
 30BASER: APPROX. 92.50 LBS

DIMENSIONS ARE FOR REFERENCE ONLY
 ACTUAL DIMENSIONS MAY VARY
 DIMENSIONS ARE IN INCHES
 GRATE MEETS H-20 LOAD RATING
 QUALITY: MATERIALS SHALL CONFORM TO ASTM A536
 GRADE 70-50-05
 PAINT: CASTINGS ARE FURNISHED WITH A BLACK PAINT
 LOCKING DEVICE AVAILABLE UPON REQUEST SEE DRAWING
 NO. 7002-110-063
 SLOPE OF GRATE SURFACE IS 5.2%
 CURB INLET FRAME INSIDE VOLUME IS APPROX 2.73 CU FT
 APPROX. DRAIN AREA OF GRATE & HOOD = 430.31

THIS PRINT DISCLOSES SUBJECT MATTER IN WHICH NYLOPLAST HAS PROPRIETARY RIGHTS. THE RECEIPT OR POSSESSION OF THIS PRINT DOES NOT CONFER, TRANSFER, OR LICENSE THE USE OF THE DESIGN OR TECHNICAL INFORMATION SHOWN HEREIN REPRODUCTION OF THIS PRINT OR ANY INFORMATION CONTAINED HEREIN, OR MANUFACTURE OF ANY ARTICLE HEREFROM, FOR THE DISCLOSURE TO OTHERS IS FORBIDDEN, EXCEPT BY SPECIFIC WRITTEN PERMISSION FROM NYLOPLAST.

©2013 NYLOPLAST

DRAWN BY	EBC	MATERIAL
DATE	04-10-06	DUCTILE IRON
REVISED BY	CCA	PROJECT NO./NAME
DATE	09-05-13	
DWG SIZE	A	SCALE 1:16 SHEET 1 OF 1

	3130 VERONA AVE BUFORD, GA 30518 PHN (770) 932-2443 FAX (770) 932-2490 www.nyloplast-us.com
	TITLE 2 FT X 3 FT ROLL CURB INLET- RIGHT FLOW GRATE ASSEMBLY
DWG NO.	7002-110-051 REV D