

**DUAL WALL FABRICATED REDUCING WYES**  
**21"×4" - 21"×18" DIAMETER**

PART #	PIPE SIZE	A	B	C	JOINT
2180AN	21 x 4 in (525 x 100 mm)	33.0 in (838 mm)	23.3 in (592 mm)	28.2 in (715 mm)	*
2180AN65B	21 x 4 in (525 x 100 mm)	28.2 in (716 mm)	23.3 in (592 mm)	22.2 in (563 mm)	WT
2181AN	21 x 6 in (525 x 150 mm)	36.0 in (914 mm)	24.3 in (617 mm)	29.6 in (752 mm)	*
2181AN65B	21 x 6 in (525 x 150 mm)	24.0 in (610 mm)	24.3 in (617 mm)	23.6 in (600 mm)	WT
2182AN	21 x 8 in (525 x 200 mm)	38.6 in (980 mm)	26.0 in (661 mm)	31.1 in (790 mm)	*
2182AN65B	21 x 8 in (525 x 200 mm)	27.0 in (686 mm)	26.0 in (661 mm)	29.1 in (738 mm)	WT
2183AN	21 x 10 in (525 x 250 mm)	42.0 in (1067 mm)	28.8 in (732 mm)	32.4 in (824 mm)	*
2183AN65B	21 x 10 in (525 x 250 mm)	30.0 in (762 mm)	28.8 in (732 mm)	26.4 in (671 mm)	WT
2184AN	21 x 12 in (525 x 300 mm)	45.0 in (1143 mm)	34.6 in (879 mm)	33.9 in (862 mm)	*
2184AN65B	21 x 12 in (525 x 300 mm)	33.0 in (838 mm)	34.6 in (879 mm)	27.9 in (709 mm)	WT
2185AN	21 x 15 in (525 x 375 mm)	48.0 in (1219 mm)	40.2 in (1022 mm)	36.9 in (938 mm)	*
2185AN65B	21 x 15 in (525 x 375 mm)	39.0 in (991 mm)	40.2 in (1022 mm)	30.9 in (786 mm)	WT
2186AN	21 x 18 in (525 x 450 mm)	51.0 in (1295 mm)	42.3 in (1075 mm)	37.8 in (960 mm)	*
2186AN65B	21 x 18 in (525 x 450 mm)	45.0 in (1143 mm)	42.3 in (1075 mm)	34.8 in (884 mm)	WT

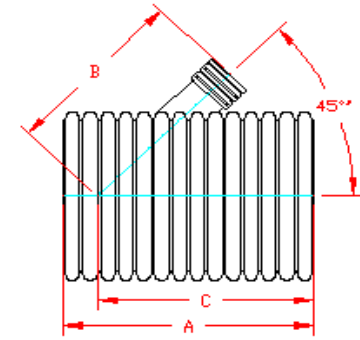

PLAIN END

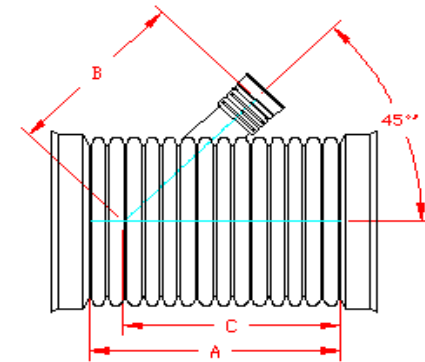

WT (INCLUDES 3 GASKETS)

\* = PLAIN END  
 ST = SOIL TIGHT  
 WT = WATER TIGHT

NOTE: ALL FITTINGS DIMENSIONS ARE FOR REFERENCE ONLY

© 2023 Advanced Drainage Systems, Inc.



DRAWING #:	2322	
DRAWN BY:	TJR	2/8/2010
APPROVED BY:		
REVISIONS:		