

Technical Note

TN 5.05 Pipe Flotation

Introduction

The light weight of high density polyethylene (HDPE) and polypropylene (PP) pipe make it desirable because of the ease of handling and installation but this same benefit also makes these thermoplastic pipes prone to flotation. All pipe products, such as concrete and corrugated metal, are prone to flotation under the right circumstances. In fact, all pipe materials and other buried structures are subject to flotation. When the uplift on the pipe or structure exceeds the downward force of the weight and load it carries, the pipe (or structure) will rise or heave. Where flotation is a possibility, proper installation and/or anchoring of the pipe is critical. This document provides an analysis on minimum cover heights required to prevent pipe flotation for thermoplastic pipe sizes 12"-60". Buoyant force due to flowable fill is also discussed.

Hydrostatic Uplift Due to a High Water Table

Buoyancy becomes an issue in buried pipe when the groundwater encroaches into the pipe zone. For projects where a high groundwater table or water surrounding the pipe is expected, precautions should be taken to prevent the flotation of thermoplastic pipe. The vertical hydrostatic uplift force, due to the water table, must be balanced by the soil overburden and the weight of the pipe in order to prevent flotation of the pipe. The vertical hydrostatic uplift force, U , can be calculated from Equation 1 below:

$$U = \frac{\pi}{4} D^2 \delta_w \quad (1)$$

where U = lb/linear ft of pipe
 D = O.D. of the pipe in question, ft.
 δ_w = unit weight of water = 62.4 lb/ft³

Soil loads experienced by a pipe at varying water table depths (W_{soil}) can be calculated from Equation 2. Figure 1 illustrates each of the three cases seen in field installations where buoyancy becomes a concern, and also clarifies all of the parameters contained within Equation 2.

$$W_{\text{soil}} = \delta_{\text{dry}} H_{\text{dry}} D + (\delta_{\text{sat}} - \delta_w)(H_{\text{sub}} + 0.1073D)D \quad (2)$$

where W_{soil} = weight of soil overburden, lb/linear ft of pipe
 δ_{dry} = dry unit weight of the soil, lb/ft³
 H_{dry} = depth of dry soil, ft.
 H_{sub} = depth of submerged soil over top of pipe, ft.
 δ_{sat} = saturated unit weight of the soil, lb/ft³
 $\delta_{\text{sat}} - \delta_w$ = submerged unit weight of the soil, lb/ft³

Figure 1
Installation Conditions for Possible Flotation of Thermoplastic Pipe

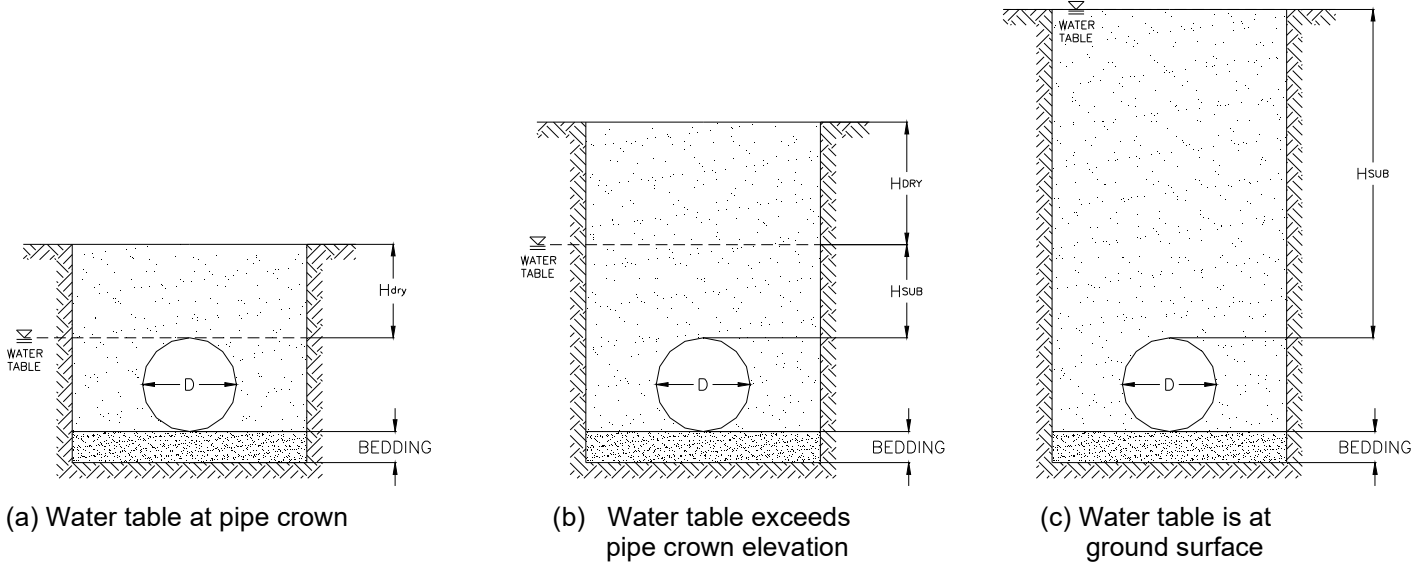

The typical weights (W_{pipe}) and average outside diameters are shown in Table 1.

Table 1
Approximate Weights of ADS Thermoplastic Pipe

Nominal Diameter in. (mm)	Nominal OD in. (mm)	Dual Wall Pipe Weight lb/ft (kg/m)	Triple Wall Pipe Weight lb/ft (kg/m)
4 (100)	4.6 (117)	0.44 (0.6)	N/A
6 (150)	7.0 (178)	0.85 (1.3)	N/A
8 (200)	9.5 (241)	1.5 (2.2)	N/A
10 (250)	12 (305)	2.1 (3.1)	N/A
12 (300)	14.5 (368)	3.2 (4.7)	N/A
15 (375)	18 (457)	4.6 (6.8)	N/A
18 (450)	22 (559)	6.4 (9.5)	N/A
24 (600)	28 (711)	11.0 (16.4)	N/A
30 (750)	36 (914)	15.4 (22.9)	20.7 (30.8)
36 (900)	42 (1067)	19.8 (29.4)	24.2 (36.0)
42 (1050)	48 (1219)	26.4 (39.3)	31.9 (47.5)
48 (1200)	54 (1372)	31.3 (46.6)	41.8 (62.3)
60 (1500)	67 (1702)	45.2 (67.3)	55.0 (81.9)

N/A indicates the pipe is not available in the respective diameter

The minimum depth of cover (H) required to resist uplift can be calculated by equating the sum of the downward forces to the sum of the upward or buoyant forces. While there are varying methods to account for soil load distribution on the pipe, for conservative minimum cover requirements, the soil load is assumed to be the soil column directly above the outside diameter of the pipe as illustrated in Figure 2(a). Therefore, minimum cover is calculated using Equations 3 and 4 below:

$$U \leq W_{Soil} + W_{Pipe} \quad (3)$$

where W_{pipe} = weight of the pipe, lb/linear ft of pipe

$$H = H_{dry} + H_{sub} \quad (4)$$

Figure 2
Forces Affecting Flotation

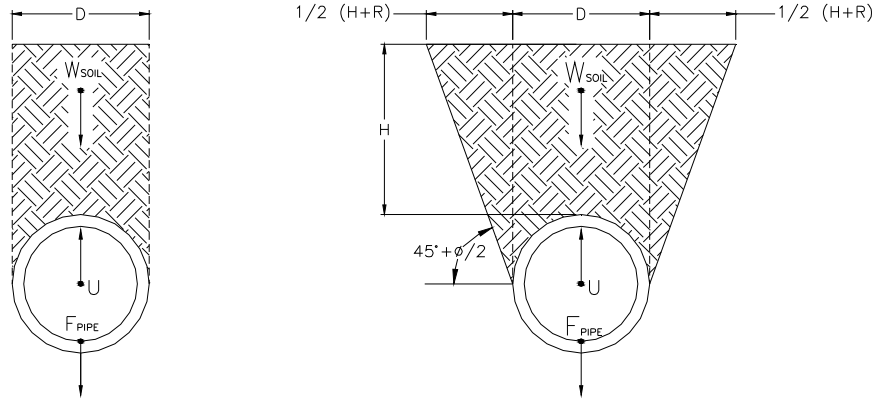

(a) Soil Column Loading Conditions

(b) Prism Loading Conditions

Table 2
Minimum Recommended Cover to Prevent Flotation of ADS Thermoplastic Pipe

Nominal Diameter in. (mm)	Minimum Cover in. (mm)
4 (100)	3 (77)
6 (150)	4 (102)
8 (200)	5 (127)
10 (250)	7 (178)
12 (300)	9 (228)
15 (375)	11 (280)
18 (450)	13 (330)
24 (600)	17 (432)
30 (750)	22 (559)
36 (900)	25 (635)
42 (1050)	29 (737)
48 (1200)	33 (838)
60 (1500)	40 (1016)

Calculation Notes:

1. The pipe is assumed to be empty. This not only simplifies the calculations but creates a condition that would encourage flotation. Unless the system is constructed to be watertight, this condition would not likely be found in an actual installation.
2. The outside diameter of the corrugated pipe was used to determine soil and water displacement.
3. Saturated soil density used was 130 pcf which is typical for many saturated soil mixtures. Soils of greater densities will reduce the chance of flotation.
4. The water table was assumed to be at the ground surface, as illustrated in Figure 1(c), simulating a fully saturated soil. This assumption creates a “worst case” condition to yield more conservative results.
5. The soil load prism shown in Figure 2(a) was used to determine soil weight.
6. For structural purposes, a minimum cover of 12” (0.3m) shall apply for 4”-48” (100-1200mm) pipe, and 24” (0.6m) for 60” (1500mm) pipe.

Example 1: Calculate the minimum depth of cover required to prevent 48" N-12 HDPE from floating when the water table is at the top of grade. The dry and saturated unit weights of the soil are 110 lb/ft³ and 130 lb/ft³, respectively.

Solution: $U > W_{Soil} + W_{Pipe}$

$$W_{pipe} = 32.0 \text{ lb/ft (from Table 1)}$$

$$U = \frac{\pi}{4} (4.5)^2 (62.4) = 992.4 \text{ lb/ft}$$

The water table is at top of grade, so Figure 1(c) applies. Since $H_{dry}=0$, the first term in Equation 2 is eliminated:

$$\text{Therefore, } W_{soil} = (130 - 62.4)[H_{sub} + (0.1073)(4.5)](4.5) + 32 = 304.2 H_{sub} + 146.9 + 32$$

$$\begin{aligned} \text{Equation 3 then yields: } & 992.4 = 304.2 H_{sub} + 178.9 \\ \therefore H_{sub} = 2.67' = 32.1" & \text{ (use 33")} \end{aligned}$$

Finally, calculate minimum cover from Equation 4: $H = H_{sub} = \underline{33"}$

The above calculations are conservative. The angle of internal friction of the soil, ϕ , and the coefficient of lateral earth stress, K_o , are not accounted for in the above equations. These parameters are best left to the geotechnical engineer. If these parameters are added to the above calculations, the depth of cover required would be reduced.

Anchoring Systems

In many instances pipe flotation may simply be addressed with adequate cover. In those situations where adequate cover cannot be achieved, there are a number of acceptable alternate methods for restraining the pipe. Several examples are shown in Figure 3.

Due to the variations in in-situ soil densities, water table heights, and the restraining force of the anchors, the Engineer should evaluate the project-specific conditions to determine the required anchor type and spacing to prevent flotation. The maximum spacing between anchor supports should not exceed 10 feet. In this manner, pipe is supported at each joint and at the midpoint of each length of pipe to ensure adequate stabilization.

**Figure 3
Pipe Stabilizing Alternatives**

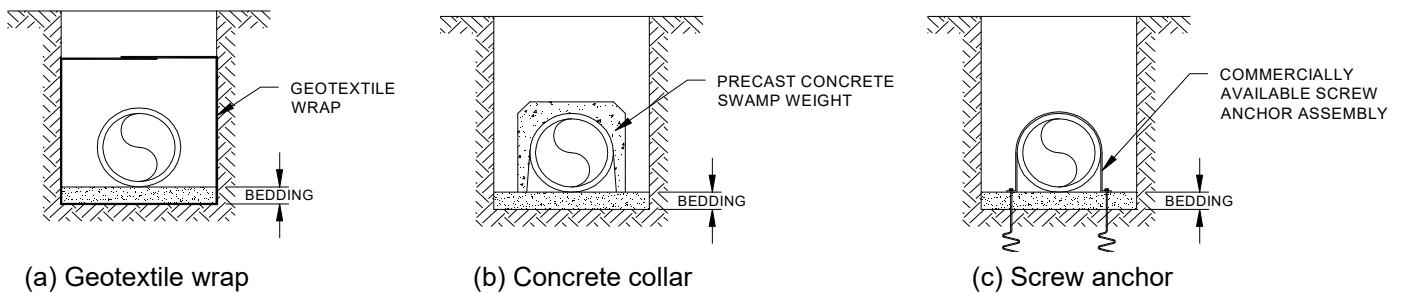

Uplift Due to Flowable Fill Backfill

Flowable fill, also known as controlled low strength material (CLSM), controlled density fill (CDF), and slurry fill, is utilized as an alternate to compacted granular fill. Flowable fill typically consists of Portland Cement, sand, water, and fly ash. Uplift due to CLSM backfill can be calculated from Equation 5.

$$U = \frac{A_{disp} \delta_{FF}}{144} \quad (5)$$

Where, A_{disp} = Area of pipe displaced by flowable fill, in²
 δ_{FF} = Unit weight of flowable fill, lb/ft³
U = Uplift due to flowable fill backfill, lb/ft

Due to the vast differences in the unit weights between water and flowable fill, uplift caused by flowable fill can be greater than two times that of hydrostatic uplift. When backfilling with flowable fill, the pipe will float in the absence of soil overburden, since the weight of the pipe will not offset the vertical uplift. Precautions must be taken to ensure the pipe remains on its intended alignment and grade. This is commonly done by anchoring the pipe in place or placing the flowable fill in incremental lifts. Refer to Technical Note 5.02: Flowable Fill Backfill for Thermoplastic Pipe for common anchoring methods and additional technical information related to placing flowable fill as backfill.

