

# 3 FT X 3 FT ROAD & HIGHWAY FRAME AND GRATE

APPROX. DRAIN AREA = 688.66 SQ IN

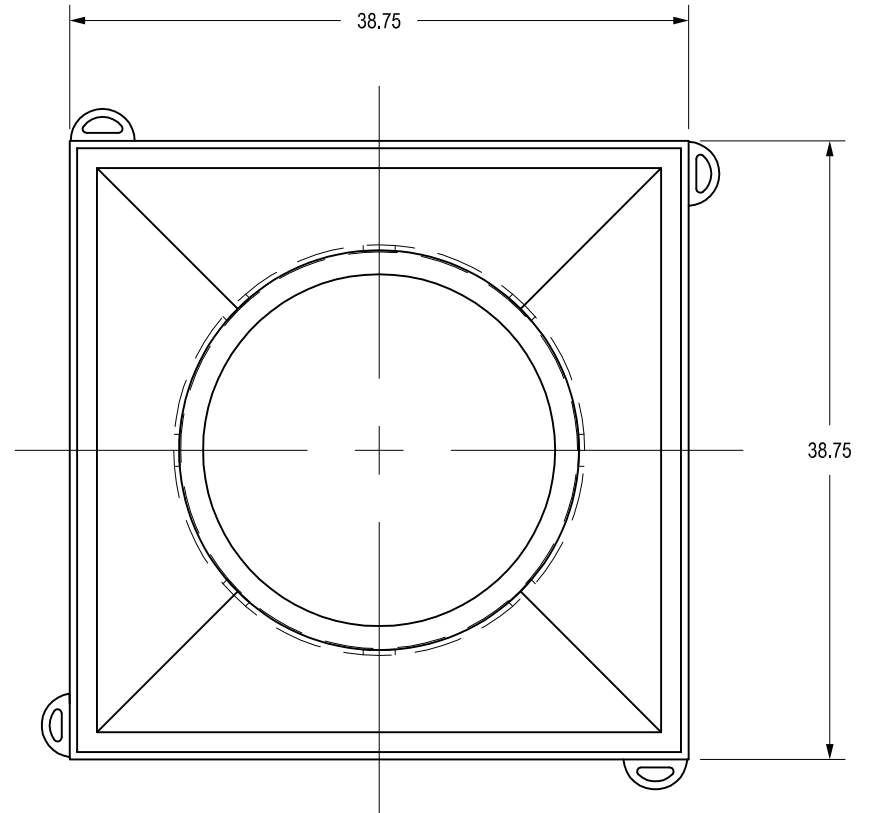
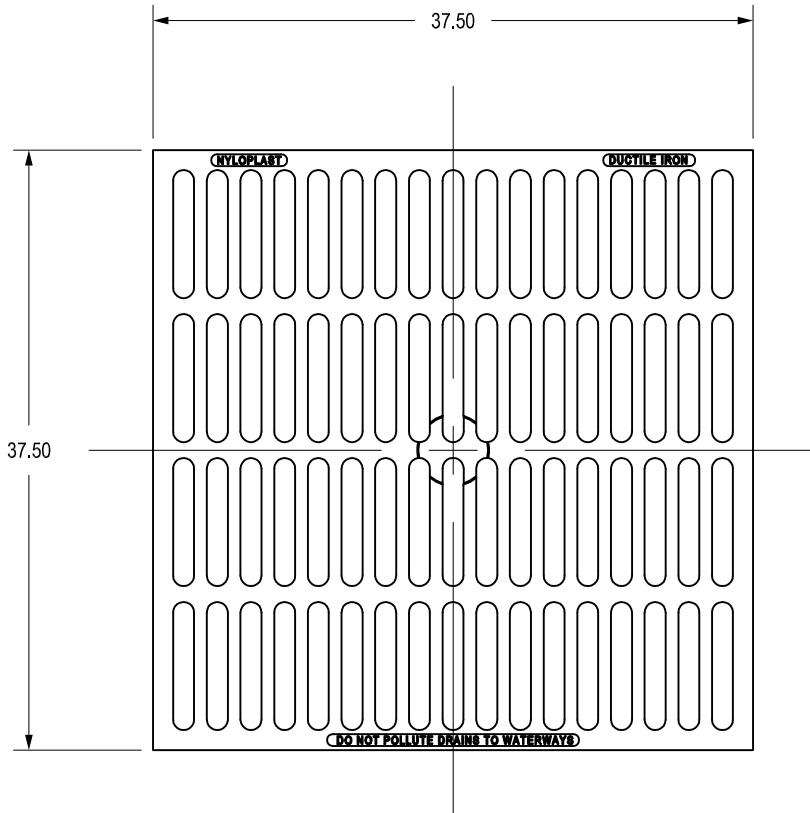
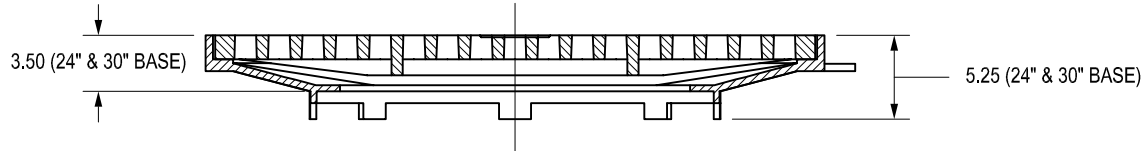

DIMENSIONS ARE FOR REFERENCE ONLY

ACTUAL DIMENSIONS MAY VARY

DIMENSIONS ARE IN INCHES

GRATE MEETS H-20 LOAD RATING

QUALITY: MATERIALS SHALL CONFORM TO ASTM A536 GRADE 70-50-05

PAINT: CASTINGS ARE FURNISHED WITH A BLACK PAINT

THIS PRINT DISCLOSES SUBJECT MATTER IN WHICH NYLOPLAST HAS PROPRIETARY RIGHTS. THE RECEIPT OR POSSESSION OF THIS PRINT DOES NOT CONFER, TRANSFER, OR LICENSE THE USE OF THE DESIGN OR TECHNICAL INFORMATION SHOWN HEREIN. REPRODUCTION OF THIS PRINT OR ANY INFORMATION CONTAINED HEREIN, OR MANUFACTURE OF ANY ARTICLE HEREFROM, FOR THE DISCLOSURE TO OTHERS IS FORBIDDEN, EXCEPT BY SPECIFIC WRITTEN PERMISSION FROM NYLOPLAST.

©2007 NYLOPLAST

DRAWN BY	NMH	MATERIAL	
DATE	12-15-17	DUCTILE IRON	
APPD BY	NMH	PROJECT NO./NAME	
DATE	12-15-17		
DWG SIZE	A	SCALE	1:12 SHEET 1 OF 1

	3130 VERONA AVE BUFORD, GA 30518 PHN (770) 932-2443 FAX (770) 932-2490 www.nyloplast-us.com		
	TITLE 3 FT X 3 FT ROAD & HIGHWAY 2 PIECE GRATE ASSEMBLY		
DWG NO.	7001-110-525	REV	A