

18 IN - 30 IN ROUND GRATE/COVER EXTENSION RING

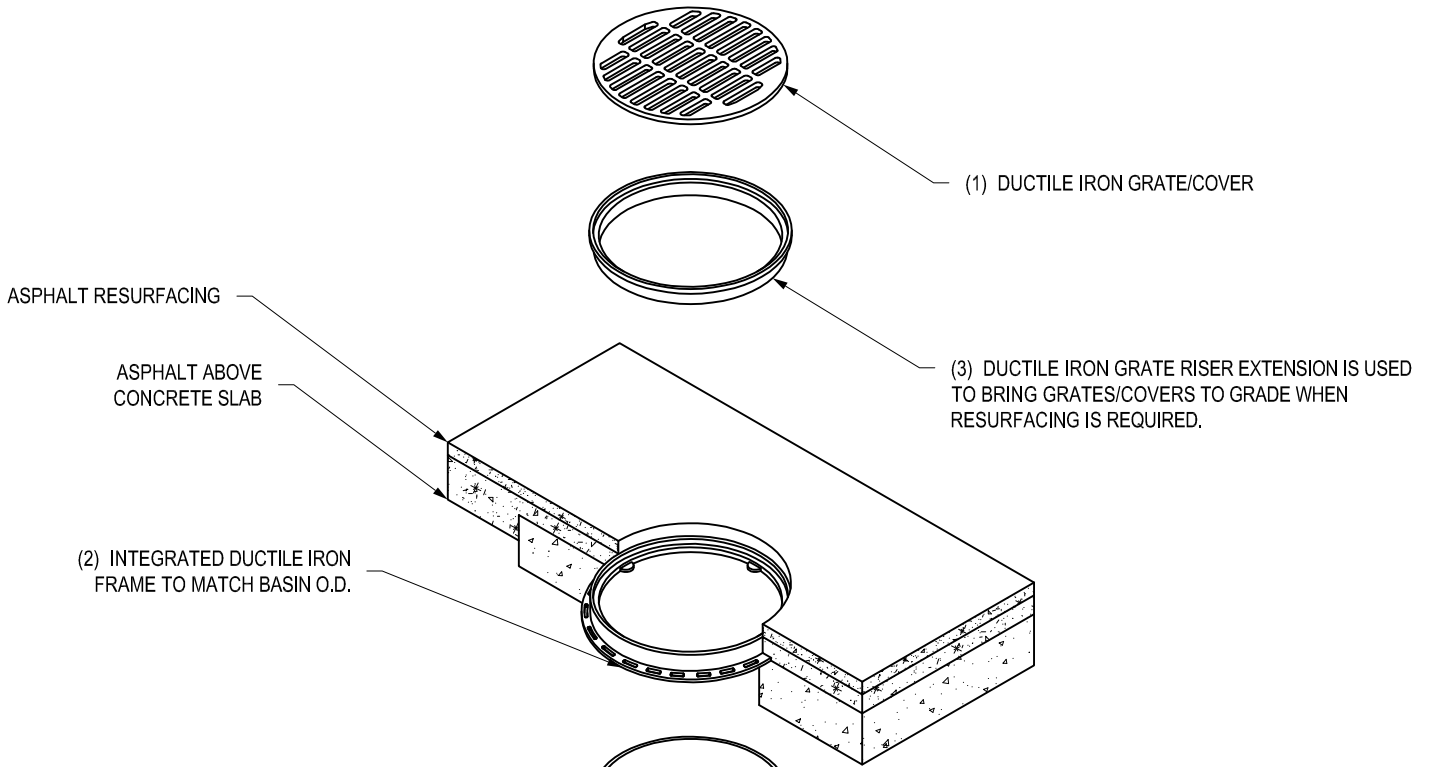

(1) DUCTILE IRON GRATE/COVER

(3) DUCTILE IRON GRATE RISER EXTENSION IS USED TO BRING GRATES/COVERS TO GRADE WHEN RESURFACING IS REQUIRED.

(2) INTEGRATED DUCTILE IRON FRAME TO MATCH BASIN O.D.

ASPHALT RESURFACING

ASPHALT ABOVE CONCRETE SLAB

| FRAME SIZE | EXTENSION HEIGHT | PART NUMBER |
|------------|------------------|-------------|
| 18" | 1.50 | 1899CGER150 |
| | 2.00 | 1899CGER200 |
| 24" | 1.50 | 2499CGER150 |
| | 2.00 | 2499CGER200 |
| 30" | 1.50 | 3099CGER150 |
| | 2.00 | 3099CGER200 |

- 1 - GRATES/SOLID COVERS SHALL BE DUCTILE IRON PER ASTM A536 GRADE 70-50-05
- 2 - FRAMES SHALL BE DUCTILE IRON PER ASTM A536 GRADE 70-50-05
- 3 - GRATE RISER EXTENSIONS SHALL BE DUCTILE IRON PER ASTM A536 GRADE 70-50-05
- 4 - DIMENSIONS ARE IN INCHES

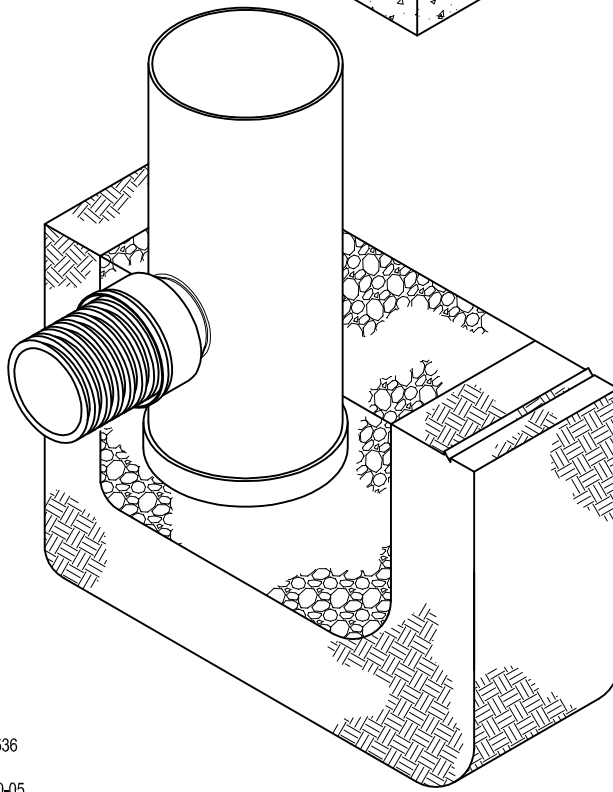

THIS PRINT DISCLOSES SUBJECT MATTER IN WHICH NYLOPLAST HAS PROPRIETARY RIGHTS. THE RECEIPT OR POSSESSION OF THIS PRINT DOES NOT CONFER, TRANSFER, OR LICENSE THE USE OF THE DESIGN OR TECHNICAL INFORMATION SHOWN HEREIN REPRODUCTION OF THIS PRINT OR ANY INFORMATION CONTAINED HEREIN, OR MANUFACTURE OF ANY ARTICLE HEREFROM, FOR THE DISCLOSURE TO OTHERS IS FORBIDDEN, EXCEPT BY SPECIFIC WRITTEN PERMISSION FROM NYLOPLAST.

©2013 NYLOPLAST

| | | | |
|-------------------|----------|-------------------------|----------|
| DRAWN BY | JJC | MATERIAL | |
| DATE | 11-03-08 | PROJECT NO./NAME | |
| REVISED BY | CCA | DATE | 09-04-13 |
| DWG SIZE | A | SCALE | 1:30 |
| | | SHEET | 1 OF 1 |



ADS
Nyloplast

3130 VERONA AVE
BUFORD, GA 30518
PHN (770) 932-2443
FAX (770) 932-2490
www.nyloplast-us.com

| | | |
|--|--------------|--------------|
| TITLE | | |
| 18 IN - 30 IN ROUND GRATE/COVER EXTENSION RING QUICK SPEC INSTALLATION DETAIL | | |
| DWG NO. | 7001-110-336 | REV C |