

DUAL WALL FABRICATED REDUCING SADDLE TEE
18" - 24" DIAMETER

PART #	PIPE SIZE	A	B
1840AN	18 x 4 (450 x 100 mm)	5.4 in (137 mm)	10.5 in (267 mm)
1841AN	18 x 6 (450 x 150 mm)	6.8 in (173 mm)	10.5 in (267 mm)
1842AN	18 x 8 (450 x 200 mm)	10.2 in (259 mm)	10.5 in (267 mm)
2140AN	21 x 4 (525 x 100 mm)	5.1 in (130 mm)	12.0 in (305 mm)
2141AN	21 x 6 (525 x 150 mm)	6.5 in (165 mm)	12.0 in (305 mm)
2142AN	21 x 8 (525 x 200 mm)	9.9 in (251 mm)	12.0 in (305 mm)
2143AN	21 x 10 in (525 x 250 mm)	10.7 in (272 mm)	12.0 in (305 mm)
2440AN	24 x 4 in (600 x 100 mm)	5.1 in (130 mm)	12.6 in (321 mm)
2441AN	24 x 6 in (600 x 150 mm)	6.5 in (165 mm)	12.6 in (321 mm)
2442AN	24 x 8 in (600 x 200 mm)	9.9 in (251 mm)	12.6 in (321 mm)
2443AN	24 x 10 in (600 x 250 mm)	10.7 in (272 mm)	12.6 in (320 mm)

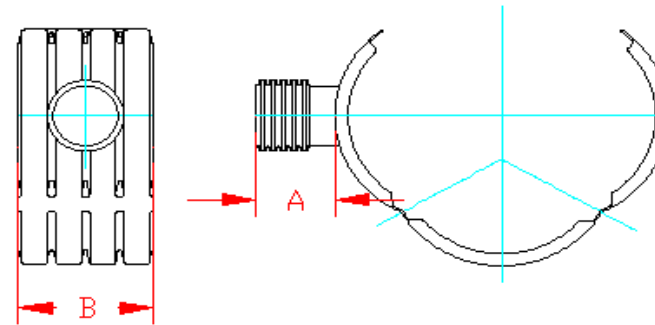

NOTE: ALL FITTINGS DIMENSIONS ARE FOR REFERENCE ONLY

© 2023 Advanced Drainage Systems, Inc.



DRAWING #:	2465	
DRAWN BY:	JCB	04.06.06
APPROVED BY:	JCB	06.26.07
REVISIONS:	TJR	4/28/2016