

3099CGRDF & 3099CGRFH

APPROX. GRATE DRAIN AREA = 232.87 SQ IN
 *APPROX. WEIGHT WITH FRAME & HOOD = 344.00 LBS

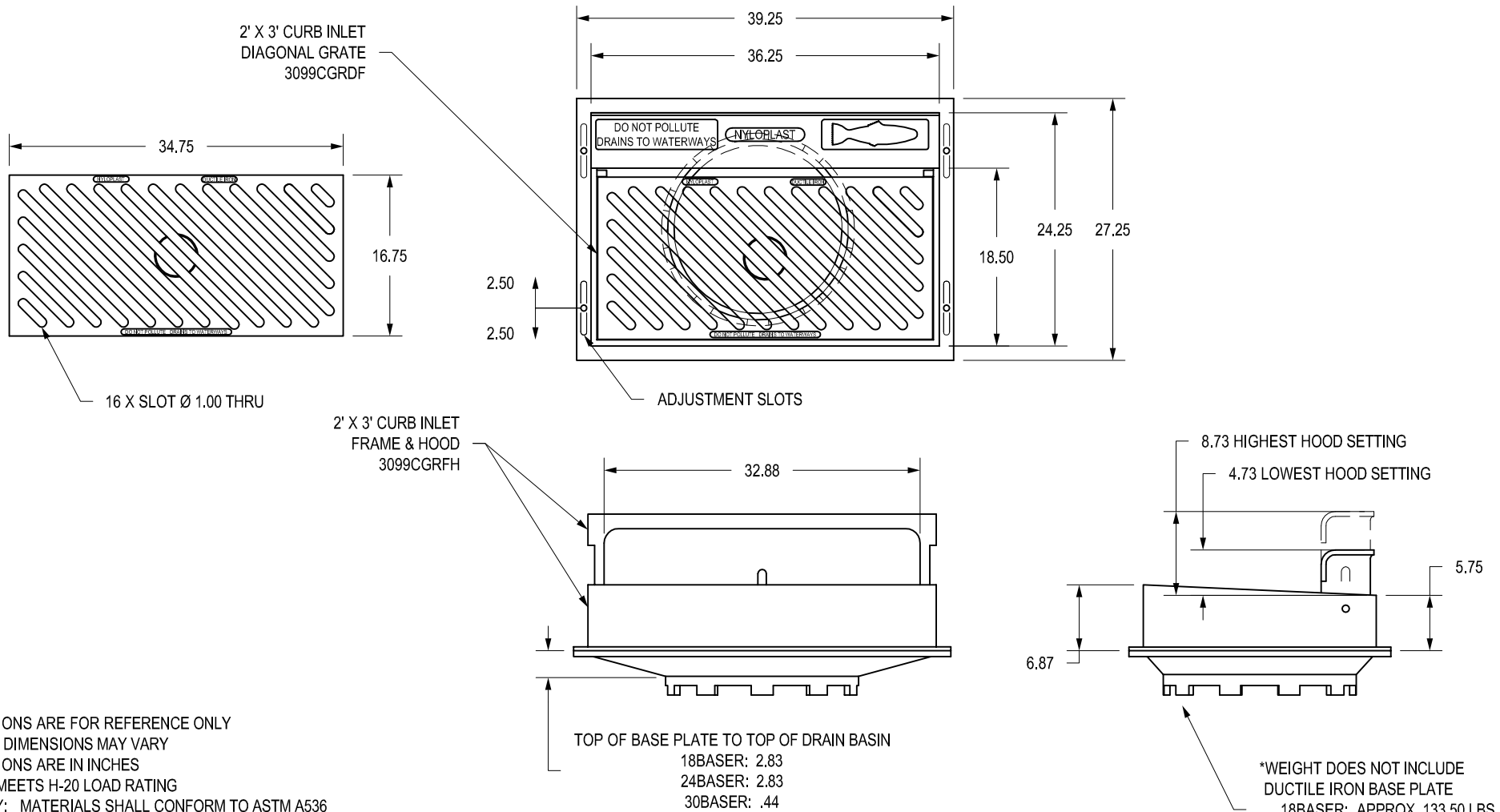

DIMENSIONS ARE FOR REFERENCE ONLY
 ACTUAL DIMENSIONS MAY VARY
 DIMENSIONS ARE IN INCHES
 GRATE MEETS H-20 LOAD RATING
 QUALITY: MATERIALS SHALL CONFORM TO ASTM A536
 GRADE 70-50-05
 PAINT: CASTINGS ARE FURNISHED WITH A BLACK PAINT
 LOCKING DEVICE AVAILABLE UPON REQUEST SEE DRAWING
 NO. 7002-110-057
 SLOPE OF GRATE SURFACE IS 5.2%
 CURB INLET FRAME INSIDE VOLUME IS APPROX 2.73 CU FT
 APPROX. DRAIN AREA OF GRATE & HOOD
 LOWEST SETTING = 369.54 SQ IN
 LOWEST + 1" SETTING = 402.41 SQ IN
 LOWEST + 2" SETTING = 435.29 SQ IN
 LOWEST + 3" SETTING = 468.16 SQ IN
 HIGHEST SETTING = 501.04 SQ IN

THIS PRINT DISCLOSES SUBJECT MATTER IN WHICH NYLOPLAST HAS PROPRIETARY RIGHTS. THE RECEIPT OR POSSESSION OF THIS PRINT DOES NOT CONFER, TRANSFER, OR LICENSE THE USE OF THE DESIGN OR TECHNICAL INFORMATION SHOWN HEREIN REPRODUCTION OF THIS PRINT OR ANY INFORMATION CONTAINED HEREIN, OR MANUFACTURE OF ANY ARTICLE HEREFROM, FOR THE DISCLOSURE TO OTHERS IS FORBIDDEN, EXCEPT BY SPECIFIC WRITTEN PERMISSION FROM NYLOPLAST.

DRAWN BY	EBC	MATERIAL
DATE	04-10-06	DUCTILE IRON
REVISED BY	CCA	PROJECT NO./NAME
DATE	09-05-13	
DWG SIZE	A	SCALE 1:16 SHEET 1 OF 1

ADS
 Nyloplast

3130 VERONA AVE
 BUFORD, GA 30518
 PHN (770) 932-2443
 FAX (770) 932-2490
 www.nyloplast-us.com

TITLE
 2 FT X 3 FT CURB INLET DIAGONAL GRATE ASSEMBLY

DWG NO. 7002-110-046 REV D

*WEIGHT DOES NOT INCLUDE
 DUCTILE IRON BASE PLATE
 18BASER: APPROX. 133.50 LBS
 24BASER: APPROX. 122.00 LBS
 30BASER: APPROX. 92.50 LBS